

Approved

State of Idaho
Division of Building Safety

PA#: BLD2303-00026

Date: 04/13/23

These documents are approved contingent on the compliance with the mark-ups and notes applied.

This approval shall not be construed to be an approval of any violation of, or variance from, Idaho's adopted codes, standards, laws or rules applicable to this project.

PROJECT MANUAL

Jefferson Elementary School Addition and Remodel

for

Jerome School District

AGENCY REVIEW SET

February 24, 2023

VOLUME TWO

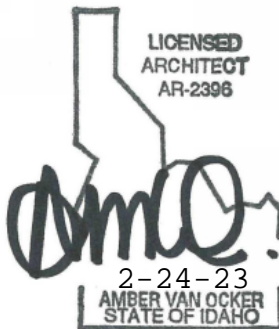

THIS PAGE INTENTIONALLY BLANK

TABLE OF CONTENTS
2/24/2023

NO. OF PAGES

VOLUME 1

INSTRUCTIONS TO BIDDERS (Volume One not included for Agency Review purposes.)

VOLUME 2

Project Architect and Engineers

DIVISION 01 – GENERAL REQUIREMENTS

Section 011000	Summary of Work and General Requirement	7
Section 012300	Alternates	3
Section 012500	Substitution Procedures	4
Section 012600	Contract Modification Procedures.....	2
Section 012900	Payment Procedures	4
Section 013100	Project Management and Coordination	9
Section 013300	Submittal Procedures	8
Section 014000	Quality Requirements	7
Section 014200	References	2
Section 015000	Construction Facilities and Temporary Controls.....	11
Section 016000	Product Requirements.....	6
Section 017300	Execution	10
Section 017329	Cutting and Patching	5
Section 017700	Closeout Procedures	4
Section 017823	Operation and Maintenance Data	7
Section 017839	Project Record Documents	3
Section 017900	Demonstration and Training.....	4
Section 019113	General Commissioning Requirements	3

DIVISION 02 – EXISTING CONDITIONS

Section 024119	Selective Structure Demolition.....	4
Section 028211	Asbestos Abatement	7
Section 028333	Lead-Based Paint Removal and Disposal.....	5

DIVISION 03 - CONCRETE

Section 033000	Cast-in-Place Concrete	19
Section 035416	Hydraulic Cement Underlayment.....	4

DIVISION 04 – MASONRY

Section 042000	Unit Masonry	18
----------------	--------------------	----

DIVISION 05 - METALS

Section 051200	Structural Steel Framing.....	9
Section 052100	Steel Joist Framing	5
Section 053100	Steel Decking.....	5
Section 054000	Cold-Formed Metal Framing.....	7

TABLE OF CONTENTS
2/24/2023

NO. OF PAGES

Section 055000	Metal Fabrications	8
Section 055213	Pipe and Tube Railings.....	8

DIVISION 06 – WOOD, PLASTICS AND COMPOSITES

Section 061000	Rough Carpentry	7
Section 061600	Sheathing	4
Section 061753	Shop-Fabricated Wood Trusses.....	9
Section 064116	Plastic Laminate Faced Architectural Cabinets.....	9
Section 066400	Plastic Paneling	4

DIVISION 07 - THERMAL AND MOISTURE PROTECTION

Section 071113	Bituminous Dampproofing	3
Section 071900	Water Repellents	4
Section 072100	Thermal Insulation.....	6
Section 072700	Infiltration Barriers	2
Section 075423	Thermoplastic Polyolefin (TPO) Roofing	10
(3) Year Roofing Warranty.....		3
Section 076200	Sheet Metal Flashing and Trim	7
Section 077200	Roof Accessories	3
Section 078413	Penetration Firestopping	6
Section 078413	Firestopping Appendix A	7
Section 079200	Joint Sealants	7

DIVISION 08 – OPENINGS

Section 081113	Hollow Metal Doors and Frames.....	11
Section 081416	Flush Wood Doors.....	5
Section 083113	Access Doors and Frames.....	4
Section 083323	Overhead Coiling Doors.....	6
Section 084113	Aluminum-Framed Entrances and Storefronts	7
Section 084523	Translucent Fiberglass Sandwich Panel Assemblies.....	6
Section 087100	Door Hardware	26
Section 088000	Glazing.....	10

DIVISION 09 - FINISHES

Section 092400	Portland Cement Plaster	5
Section 092900	Gypsum Board	7
Section 093013	Tiling	8
Section 095113	Acoustical Panel Ceilings.....	7
Section 096466	Wood Athletic Flooring.....	6
Section 096513	Resilient Base and Accessories	7
Section 096516	Resilient Sheet Flooring	5
Section 096519	Resilient Tile Flooring.....	5
Section 096816	Carpeting	5
Section 097200	Digitally Printed Vinyl Wallcovering Murals	5
Section 098413	Fixed Sound-Absorptive Panels	3
Section 099113	Exterior Painting	6
Section 099123	Interior Painting.....	7

TABLE OF CONTENTS
2/24/2023

NO. OF PAGES

DIVISION 10 - SPECIALTIES

Section 101100	Visual Display Surfaces	7
Section 101416	Signage.....	4
Section 102113	Toilet Compartments	4
Section 102600	Wall and Door Protection	4
Section 102800	Toilet and Bath Accessories	3
Section 104413	Fire Extinguisher Cabinets	3
Section 104416	Fire Extinguishers.....	3

DIVISION 11 - EQUIPMENT

Section 113013	Residential Appliances	3
Section 114000	Food Service Equipment.....	12
Section 115213	Projection Screens	3
Section 116143	Platform Curtains.....	5
Section 116600	Wall and Floor Padding.....	4
Section 116623	Gymnasium Equipment	6

DIVISION 12 - FURNISHINGS

Section 122113	Horizontal Louver Blinds	4
Section 126600	Telescoping Stands.....	6

VOLUME 3

DIVISION 21- FIRE SUPPRESSION

Section 210000	Fire Sprinkler Systems	5
Fire Penetration Appendix A		7

DIVISION 22- PLUMBING

Section 220000	Plumbing General Requirements.....	5
Section 220100	Plumbing.....	9

DIVISION 23- HVAC

Section 230000	HVAC General Requirements	8
Section 230100	Heating, Ventilating and Air Conditioning	16
Section 230150	Mechanical Start-Up.....	3
Section 230800	HVAC Commissioning Requirements	6
Section 230900	Direct Digital Control System	12

DIVISION 26 - ELECTRICAL

Section 260500	Electrical General Provisions	4
Section 260501	Field Test and Operational Check	3
Section 260502	Coordination Study.....	4

TABLE OF CONTENTS
2/24/2023

NO. OF PAGES

Section 260519	Conductors and Cables	3
Section 260526	Grounding	5
Section 260529	Supporting Devices	2
Section 260533	Raceways and Boxes	8
Section 260536	Cable Trays	2
Section 260543	Under Slab and Underground Electrical Work	2
Section 260800	Lighting Systems Commissioning	3
Section 260923	Lighting Control Devices	8
Section 262413	Switchboards	3
Section 262416	Panelboards	6
Section 262726	Wiring Devices	4
Section 262813	Fuses	3
Section 262815	Disconnect Switches	2
Section 265100	Interior Lighting	5
Section 266000	Electrical Demolition and Repair	2

DIVISION 27 - COMMUNICATIONS

Section 271101	Telecom Raceway Systems	1
Section 271500	Telecommunications Cabling	11
Section 275116	Integrated Communications and Clock Network	16
Section 275118	Sound Systems	6
Section 275200	Classroom Audio System	6

DIVISION 28 - ELECTRONIC SAFETY AND SECURITY

Section 281000	Access Control System	11
Section 282310	Video Management System	14
Section 282329	Video Surveillance Remote Devices and Sensors	10
Section 283200	Voice Evacuation Fire Alarm System	10

DIVISION 31 – EARTHWORK

Section 310120	Traffic Control	2
Section 311000	Site Clearing	6
Section 312300	Earthwork	12
Section 315000	Excavation Support and Protection	5

DIVISION 32 – EXTERIOR IMPROVEMENTS

Section 321216	Asphalt Paving	10
Section 321313	Concrete Paving	16
Section 321373	Concrete Paving Joint Sealants	7
Section 321723	Pavement Markings	3
Section 321726	Tactile Warning Surfacing	5
Section 321800	Playground Equipment and Structures	6
Section 321816	Playground Surface Systems	6
Section 321822	Synthetic Playground Turf	7
Section 323113	Chain Link Fences and Gates	11
Section 323119	Decorative Metal Fences and Gates	7
Section 323150	Site Signage	2

TABLE OF CONTENTS
2/24/2023

NO. OF PAGES

Section 323300	Site Furnishings	3
Section 328400	Landscape Irrigation	12
Section 328500	Landscape Grading	2
Section 329113	Soil Preparation	12
Section 329200	Turf and Grasses	13
Section 329290	Tree Protection and Trimming	4
Section 329300	Plants	15

DIVISION 33 – UTILITIES

Section 331100	Site Water Lines	3
Section 333100	Site Sanitary Sewerage System	4
Section 334100	Storm Utility Drainage Piping	15
Section 334600	Subdrainage	3

VOLUME 4

APPENDIX A

Geotechnical Evaluation Report	25
--------------------------------------	----

APPENDIX B

Asbestos and Lead-Based Paint Testing Report	73
--	----

END OF TABLE OF CONTENTS

THIS PAGE INTENTIONALLY BLANK

PROJECT ARCHITECT AND ENGINEERS

ARCHITECT	OWNER
LKV Architects 2400 E. Riverwalk Drive Boise, Idaho 83706 Phone: 208-336-3443 Wayne Thowless, Project Architect Email: wayne@lkvarchitects.com	Jerome School District 125 4 th Ave. West Jerome, Idaho 83338 Phone: 208-324-2392 Brian Bridwell Brian.bridwell@jeromeschools.org

CIVIL ENGINEER	LANDSCAPE ARCHITECT
Breckon Land Design 6661 N. Glenwood Street Boise, Idaho 83714 Phone: 208-376-5153 Jon Breckon Email: jbreckon@breckonld.com	Breckon Land Design 6661 N. Glenwood Steet Boise, Idaho 83714 Phone: 208-376-5153 Jon Breckon Email: jbreckon@breckonld.com

STRUCTURAL ENGINEER	INTERIOR DESIGNER
Lochsa Engineering 201 N. Maple Grove Road, Ste. 100 Boise, Idaho 83704 Phone: 208-342-7168 Chris Holladay Email: cholladay@lochsaidaho.com	Weston Design Interiors 201 Parkway Drive Boise, Idaho 83706 Phone: 208-343-7878 Diane Weston Email: westondesign14@gmail.com

MECHANICAL ENGINEER	ELECTRICAL ENGINEER
Musgrove Engineering 234 S. Whisperwood Way Boise, Idaho 83709 Phone: 208-384-0585 Bill Carter Email: billc@musgrovepa.com	Musgrove Engineering 234 S. Whisperwood Way Boise, Idaho 83709 Phone: 208-384-0585 Kurt Lechtenberg Email: kurtl@musgrovepa.com

CONSTRUCTION MANAGER	
Starr Corporation 2995 E. 3600 N. Twin Falls, Idaho 83301 Phone: 208-731-5699 Jason Derricott Email: jason@starrcorporation.com	

THIS PAGE INTENTIONALLY BLANK

SECTION 011000 – SUMMARY OF WORK AND GENERAL REQUIREMENTS

PART 1 - GENERAL

1.1 RELATED DOCUMENTS

- A. Drawings and general provisions of the Contract, including General and Supplementary Conditions and other Division 01 Specification Sections, apply to this Section.

1.2 SUMMARY

- A. Section Includes:

1. Project information.
2. Work covered by Contract Documents.
3. Phased construction.
4. Owner-furnished products.
5. Access to site.
6. Coordination with Occupants.
7. Work restrictions.
8. Hazardous Materials.
9. Specification and Drawing conventions.
10. Miscellaneous provisions.

- B. Related Requirements:

1. Section 015000 "Temporary Facilities and Controls" for limitations and procedures governing temporary use of Owner's facilities.

1.3 PROJECT INFORMATION

- A. Project Identification: Jefferson Elementary School Addition and Remodel

1. Project Location: 600 N. Fillmore Street, Jerome, Idaho 83338

- B. Owner: Jerome School District

1. Owner's Representative: Brian Bridwell, District Financial Administrator

- C. Architect: LKV Architects

Project Architect: Wayne Thowless

- D. Architect's Consultants: Architect has retained the following design professionals who have prepared designated portions of the Contract Documents:

Civil Engineer:
Breckon Land Design
6661 N. Glenwood Dr.
Boise, Idaho 83714
Phone: (208) 376-5153
Jon Breckon
Email: jbreckon@breckonld.com

Landscape Architect:
Breckon Land Design
6661 N. Glenwood Dr.
Boise, Idaho 83714
Phone: (208) 376-5153
Jon Breckon
Email: jbreckon@breckonld.com

Structural Engineer:
Lochsa Engineering
201 N. Maple Grove Road, Ste. 100
Boise, Idaho 83704
Phone: (208) 342-7168
Chris Holladay
Email: cholladay@lochsaidaho.com

Interior Designer:
Weston Design, Interiors
201 Parkway Drive
Boise, Idaho 83706
Phone: (208) 343-7878
Diane Weston
Email: westondesign14@gmail.com

Mechanical Engineer:
Musgrove Engineering
234 S. Whisperwood Way
Boise, Idaho 83709
Phone: (208) 384-0585
Bill Carter
Email: billc@musgrovepa.com

Electrical Engineer:
Musgrove Engineering
234 S. Whisperwood Way
Boise, Idaho 83709
Phone: (208) 384-0585
Kurt Lechtenberg
Email: kurtl@musgrovepa.com

E. Other Owner Consultants: Owner has retained the following design professionals who have prepared designated portions of the Contract Documents:

1. Geotechnical Report: EHM Engineers, Inc., dated 6/24/2014. See Appendix A.
2. Asbestos and Lead Based Paint Report: Atlas, Inc., dated 1/19/2023. See Appendix B.

F. Construction Manager: Starr Corporation

2995 E. 3600 N.
Twin Falls, Idaho 83301
Phone: (208) 731-5699
Jason Derricott
Email: jason@starrcorporation.com

1. Construction Manager has been engaged for this Project to serve as an advisor to Owner and to provide assistance in administering the Contract for construction between Owner and each Contractor, according to a separate contract between Owner and Construction Manager.
2. Starr Corporation is the Construction Manager / General Contractor (CMGC) for this project. The word "Contractor" in Division 1 Specification Sections shall apply to both the project CMGC and project subcontractors, as applicable. The word "Contractor" in all other Specification Sections shall apply to the respective subcontractor.

- G. Web-Based Project Software: Project software administered by Construction Manager will be used for purposes of managing communication and documents during the construction stage.
 - 1. See Section 013100 "Project Management and Coordination." for requirements for using web-based Project software.

1.4 WORK COVERED BY CONTRACT DOCUMENTS

- A. The Work of Project is defined by the Contract Documents and consists of the following:
 - 1. Approximately 12,000 sq. ft. of new single story elementary school construction, approximately 51,000 sq. ft. of existing elementary school building remodeling with various types of alterations, along with related exterior site work and playground improvements as indicated in the Contract Documents.
- B. Type of Contract:
 - 1. Project will be constructed under coordinated, concurrent multiple contracts. See the individual Bid Package Summary for a description of work included under each of the multiple contracts.

1.5 PHASED CONSTRUCTION

- A. The Work shall be conducted in phases with differing commencement and completion schedules as outlined in the Project Construction Schedule.
- B. Before commencing Work of each phase, submit an updated copy of Contractor's construction schedule showing sequence, commencement, and completion dates, and move-out and move-in dates of Owner's personnel as applicable.

1.6 OWNER-FURNISHED PRODUCTS

- A. Owner will furnish products indicated. The Work includes receiving, unloading, handling, storing, protecting, and installing Owner-furnished products.
- B. Owner-Furnished Products:
 - 1. Coordination of Owner supplied information technology components.
 - 2. Coordination of Owner supplied equipment and furnishings.

1.7 ACCESS TO SITE

- A. General: Each Contractor shall have limited use of Project Site for construction operations as indicated on Drawings by the Contract limits and as indicated by requirements of this Section.
- B. Use of Site: Limit use of Project Site to areas within the Contract limits indicated. Do not disturb portions of project site or building beyond areas in which the Work is indicated.

1. Driveways, Walkways and Entrances: Keep driveways parking areas, loading areas, and entrances serving premises clear and available to the Owner and Construction Manager. Do not use these areas for parking or for storage of materials.
 - a. Schedule deliveries to minimize use of driveways and entrances by construction operations.
 - b. Schedule deliveries to minimize space and time requirements for storage of materials and equipment on-site.
- C. Condition of Existing Building and Grounds: Maintain portions of existing building, grounds, landscaping, and hardscaping beyond that affected by construction operations throughout construction period. Repair damage caused by construction operations.

1.8 COORDINATION WITH OWNER OCCUPANTS

- A. Owner Limited Occupancy of Portions of Building and Completed Areas of Construction: Owner reserves the right to leave furnishings and equipment in portions of building not undergoing major modifications. Protection of such furnishings and equipment shall be protected as necessary by the Contractor. The Owner further reserves the right to occupy and to place and install equipment in completed portions of the Work prior to Substantial Completion of the Work, provided such occupancy does not interfere with completion of the Work. Such placement of equipment and limited occupancy shall not constitute acceptance of the total Work.
 1. Architect will prepare a Certificate of Substantial Completion for each specific portion of the Work to be occupied prior to Owner acceptance of the completed Work.
 2. Obtain a Certificate of Occupancy from authorities having jurisdiction before limited Owner occupancy.
 3. Before limited Owner occupancy, mechanical and electrical systems shall be fully operational, and required tests and inspections shall be successfully completed. On occupancy, Owner will operate and maintain mechanical and electrical systems serving occupied portions of Work.
 4. On occupancy, Owner will assume responsibility for maintenance and custodial service for occupied portions of Work.

1.9 WORK RESTRICTIONS

- A. Work Restrictions, General: Comply with restrictions on construction operations.
 1. Comply with limitations on use of public streets and with other requirements of authorities having jurisdiction.
 2. Comply with limitations set by Owner on access to, use of, and work in portions of the building at specified times and for specified periods.
- B. On-Site Work Hours: Limit work to normal business working hours of 7:00 a.m. to 6:00 p.m., Monday through Friday, unless otherwise indicated.

1. Weekend Hours: As approved by the Owner and Construction Manager.
- C. Existing Utility Interruptions: Do not interrupt utilities serving facilities occupied by Owner or others unless permitted under the following conditions and then only after providing temporary utility services according to requirements indicated:
1. Notify Construction Manager and Owner not less than two days in advance of proposed utility interruptions.
 2. Obtain Construction Manager's and Owner's written permission before proceeding with utility interruptions.
- D. Noise, Vibration, and Odors: Coordinate operations that may result in high levels of noise and vibration, odors, or other disruption to Owner occupancy with Owner.
1. Notify Construction Manager and Owner not less than two days in advance of proposed disruptive operations.
 2. Obtain Construction Manager's and Owner's written permission before proceeding with disruptive operations.
- E. Restricted Substances: Use of tobacco products and other controlled substances on Project site is not permitted.
- F. Employee Identification: Provide identification tags for Contractor personnel working on Project site. Require personnel to use identification tags at all times.
- G. Employee Screening: Comply with Owner's requirements for drug and background screening of Contractor personnel working on Project site.

1.10 HAZARDOUS MATERIALS

- A. Hazardous materials including asbestos and lead-based paint are present in portions of the building undergoing renovation and remodeling. The CMGC shall submit the required EPA-NESHAP "Courtesy" Notification of Renovation or the required 10-day Notification of Renovation. Hazardous material shall be handled, abated, transported, and disposed of per the procedures and protocols outlined in Specification Sections 028211 and 028333.
- B. Asbestos and Lead-Based Paint test results, from a survey and sampling performed by Atlas, Inc., is included in the Appendix of this Project Manual.

1.11 SPECIFICATION AND DRAWING CONVENTIONS

- A. Specification Content: The Specifications use certain conventions for the style of language and the intended meaning of certain terms, words, and phrases when used in particular situations. These conventions are as follows:
1. Imperative mood and streamlined language are generally used in the Specifications. The words "shall," "shall be," or "shall comply with," depending on the context, are implied where a colon (:) is used within a sentence or phrase.

2. Specification requirements are to be performed by Contractor unless specifically stated otherwise.
- B. Division 01 General Requirements: Requirements of Sections in Division 01 apply to the Work of all Sections in the Specifications.
 - C. Drawing Coordination: Requirements for materials and products identified on Drawings are described in detail in the Specifications. One or more of the following are used on Drawings to identify materials and products:
 1. Terminology: Materials and products are identified by the typical generic terms used in the individual Specifications Sections.
 2. Abbreviations: Materials and products are identified by abbreviations published as part of the U.S. National CAD Standard and scheduled on Drawings.
 3. Keynoting: Materials and products are identified by reference keynotes referencing Specification Section numbers found in this Project Manual.
 - D. Requirements of Drawings and Specifications: All items of Work shown or noted on the Drawings and / or described in the Project Manual shall be provided by the Contractor as a part of his Work. Should an item be shown or noted on the Drawings and not described in the Project Manual, the Contractor shall provide the item at no additional cost to the Owner. Should an item be described in the Project Manual and not shown or noted on the Drawings, the Contractor shall provide the item at no additional cost to the Owner.

1.12 WORK NOT NOTED, DETAILED, OR SPECIFIED

- A. All work required for a complete installation or assembly shall be included in the Contractor's bid. Where minor portions of required work are not noted, detailed or specified, such work shall be done in accordance with proven construction practice, industry standards, or as directed by Architect. Such required work shall be done at no additional cost to Owner.

1.13 DIMENSIONS AND MEASUREMENTS

- A. Contractor shall field verify all dimensions pertaining to the work and shall be responsible for the determination of all quantities of materials required for the work and for the accuracy of all dimensions of materials and items fabricated for this project. Contractor shall not rely on the scale drawings in the project Drawings in the determination of exact quantities or dimensions.

1.14 GENERAL INSTALLATION PROVISIONS

- A. Inspection of Conditions: Contractor shall inspect both the substrate and conditions under which Work is to be performed. Installation of affected components shall not proceed until unsatisfactory conditions have been corrected in an acceptable manner.
- B. Manufacturer's Instructions. Contractor shall comply with manufacturer's installation instructions and recommendations, to the extent that those instructions and recommendations are more explicit or stringent than requirements contained in Contract Documents.
- C. Contractor shall inspect materials or equipment immediately upon delivery and prior to installation and shall reject damaged and defective items.

- D. Contractor shall provide all attachment and connection devices and methods necessary for securing Work. Secure Work true to line and level. Allow for expansion and building movement.
- E. Visual Effects: Contractor shall provide uniform joint widths in exposed Work. Arrange joints in exposed Work to obtain the best visual effect. Refer questionable choices to Architect for final decision.
- F. Contractor shall check and recheck measurements, dimensions, and elevations before starting each installation and shall be responsible for the accuracy of all measurements, dimensions, and elevations.
- G. Contractor shall install each component during acceptable weather conditions.

1.15 CLEANING AND PROTECTION

- A. During handling and installation, The Contractor shall clean and protect construction in progress and adjoining materials in place. Apply protective coverings where required to ensure protection from damage or deterioration at Substantial Completion.
- B. The Contractor shall clean and maintain completed construction as frequently as necessary through the construction period. Adjust and lubricate operable components to ensure operability without damaging effects.
- C. Limiting Exposures: The Contractor shall supervise construction activities to ensure that no part of the construction, completed or in progress, is subject to harmful, dangerous, damaging or otherwise deleterious exposure from any source during the construction period.

PART 2 - PRODUCTS (Not Used)

PART 3 - EXECUTION (Not Used)

END OF SECTION 011000

THIS PAGE INTENTIONALLY BLANK

SECTION 012300 - ALTERNATES

PART 1 - GENERAL

1.1 RELATED DOCUMENTS

- A. Drawings and general provisions of the Contract, including General and Supplementary Conditions and other Division 01 Specification Sections, apply to this Section.

1.2 SUMMARY

- A. Section includes administrative and procedural requirements for alternates.

1.3 DEFINITIONS

- A. Alternate: An amount proposed by bidders and stated on the Bid Form for certain work defined in the bidding requirements that may be added to or deducted from the base bid amount if the Owner decides to accept a corresponding change either in the amount of construction to be completed or in the products, materials, equipment, systems, or installation methods described in the Contract Documents.
 - 1. Alternates described in this Section are part of the Work only if enumerated in the Agreement.
 - 2. The cost or credit for each alternate is the net addition to or deduction from the Contract Sum to incorporate alternates into the Work. No other adjustments are made to the Contract Sum.

1.4 PROCEDURES

- A. Coordination: Revise or adjust affected adjacent work as necessary to completely integrate work of the alternate into Project.
 - 1. Include as part of each alternate, miscellaneous devices, accessory objects, and similar items incidental to or required for a complete installation whether or not indicated as part of alternate.
- B. Execute accepted alternates under the same conditions as other work of the Contract.
- C. Schedule: A schedule of alternates is included at the end of this Section. Specification Sections referenced in schedule contain requirements for materials necessary to achieve the work described under each alternate.

PART 2 - PRODUCTS (Not Used)

PART 3 - EXECUTION

3.1 SCHEDULE OF ALTERNATES

A. Bid Alternate No. 1 (Additive) – Corridor Finish and Opening Upgrades.

1. Alternate Bid No. 1 shall consist of all Work related to furnishing and installing new Corridor floor, base, and / or wall finishes at identified locations in identified existing building Corridors; furnishing and installing new Corridor doors, frames and / or door hardware at identified Corridor door openings; and furnishing and installing visual display boards and digitally printed wall mural. This price shall include all aspects of construction, including selective demolition and disposal of removed materials, required patching of and / or modifications to related construction, procurement and installation of specified materials products at specified locations, incidental electrical work, and final caulking, painting, and cleaning, and shall include any necessary modifications to the Base Bid cost to complete the required work. See Architectural, Structural, and Electrical Drawings and Specifications for specific floor, base, wall surfaces included, for specific doors, frames, and door hardware included, for product requirements, and for related, required work.

B. Bid Alternate No. 2 (Additive) – Roof-top HVAC Equipment Replacement.

1. Alternate Bid No. 2 shall consist of all Work related to furnishing and installing new replacement roof-top HVAC units on existing portions of the existing building. This price shall include all aspects of construction, including removal and disposal of existing units, curb modifications or replacement, procurement and installation of specified units, required ducting modifications and connections, curb flashing and related roof repairs, electrical connections, and testing and balancing, and shall include any necessary modifications to the Base Bid cost to complete the required work. See Architectural, Mechanical, and Electrical Drawings and Specifications for number of units, locations, details, product requirements, and related required work.

C. Bid Alternate No. 3 (Additive) – New Cafeteria Windows.

1. Alternate Bid No. 3 shall consist of all work related to furnishing and installing new aluminum framed windows in the east wall of New Cafeteria 163. This price shall include all aspects of construction, including selective wall demolition, material disposal, structural reinforcement, procurement and installation of specified windows, and final caulking and cleaning, and shall include any necessary modifications to the Base Bid cost to complete the required work. See Architectural and Structural Drawings and Specifications for location, quantity, details, product requirements, and related required work.

D. Bid Alternates No. 4A, 4B, 4C, 4D, 4E, 4F (Additive) – Supplemental Playground Upgrades.

1. Alternate Bids No. 4A – 4F shall consist of all work related to furnishing and installing new playground equipment, surfacing, and related improvements over and above the

scope of Base Bid playground improvements. These prices shall include all aspects of construction, including selective site demolition and disposal of removed materials, procurement and installation of specified surfacing and substrate materials, play equipment, and related items, and shall include any necessary modifications to the Base Bid cost to complete the required work. See Civil and Landscape Drawings and Specifications for location and extent of required work; type and quantity of play equipment; product requirements; and related required work.

END OF SECTION 012300

THIS PAGE INTENTIONALLY BLANK

SECTION 012500 - SUBSTITUTION PROCEDURES

PART 1 - GENERAL

1.1 RELATED DOCUMENTS

- A. Drawings and general provisions of the Contract, including General and Supplementary Conditions and other Division 01 Specification Sections, apply to this Section.

1.2 SUMMARY

- A. Section includes administrative and procedural requirements for substitutions.
- B. Related Requirements:
 - 1. Section 012300 "Alternates" for products selected under an alternate.
 - 2. Section 016000 "Product Requirements" for requirements for submitting comparable product submittals for products by listed manufacturers.

1.3 DEFINITIONS

- A. Substitutions: Changes in products, materials, equipment, and methods of construction from those required by the Contract Documents.
 - 1. Substitutions for Cause: Changes proposed by Contractor that are required due to changed Project conditions, such as unavailability of product, regulatory changes, or unavailability of required warranty terms.
 - 2. Substitutions for Convenience: Changes proposed by Contractor or Owner that are not required to meet other Project requirements but may offer advantage to Contractor or Owner.

1.4 ACTION SUBMITTALS

- A. Substitution Requests: Submit documentation identifying product or fabrication or installation method to be replaced. Include Specification Section number and title and Drawing numbers and titles.
 - 1. Substitution Request Form: Use form acceptable to Architect.
 - 2. Documentation: Show compliance with requirements for substitutions and the following, as applicable:
 - a. Statement indicating why specified product or fabrication or installation method cannot be provided, if applicable.
 - b. Coordination of information, including a list of changes or revisions needed to other parts of the Work and to construction performed by Owner and separate contractors that will be necessary to accommodate proposed substitution.

- c. Detailed comparison of significant qualities of proposed substitutions with those of the Work specified. Include annotated copy of applicable Specification Section. Significant qualities may include attributes, such as performance, weight, size, durability, visual effect, sustainable design characteristics, warranties, and specific features and requirements indicated. Indicate deviations, if any, from the Work specified.
 - d. Product Data, including drawings and descriptions of products and fabrication and installation procedures.
 - e. Samples, where applicable or requested.
 - f. Certificates and qualification data, where applicable or requested.
 - g. List of similar installations for completed projects, with project names and addresses as well as names and addresses of architects and owners.
 - h. Material test reports from a qualified testing agency, indicating and interpreting test results for compliance with requirements indicated.
 - i. Research reports evidencing compliance with building code in effect for Project, from ICC-ES.
 - j. Detailed comparison of Contractor's construction schedule using proposed substitutions with products specified for the Work, including effect on the overall Contract Time. If specified product or method of construction cannot be provided within the Contract Time, include letter from manufacturer, on manufacturer's letterhead, stating date of receipt of purchase order, lack of availability, or delays in delivery.
 - k. Cost information, including a proposal of change, if any, in the Contract Sum.
 - l. Contractor's certification that proposed substitution complies with requirements in the Contract Documents, except as indicated in substitution request, is compatible with related materials and is appropriate for applications indicated.
 - m. Contractor's waiver of rights to additional payment or time that may subsequently become necessary because of failure of proposed substitution to produce indicated results.
3. Architect's Action: If necessary, Architect will request additional information or documentation for evaluation within seven days of receipt of a request for substitution. Architect will notify Contractor through Construction Manager of acceptance or rejection of proposed substitution within 15 days of receipt of request, or seven days of receipt of additional information or documentation, whichever is later.
- a. Forms of Acceptance: Change Order, Construction Change Directive, or Architect's Supplemental Instructions for minor changes in the Work.
 - b. Use product specified if Architect does not issue a decision on use of a proposed substitution within time allocated.

1.5 QUALITY ASSURANCE

- A. Compatibility of Substitutions: Investigate and document compatibility of proposed substitution with related products and materials. Engage a qualified testing agency to perform compatibility tests recommended by manufacturers.

1.6 PROCEDURES

- A. Coordination: Revise or adjust affected work as necessary to integrate work of the approved substitutions.

1.7 SUBSTITUTIONS

- A. Substitutions for Cause: Submit requests for substitution immediately on discovery of need for change, but not later than 15 days prior to time required for preparation and review of related submittals.

- 1. Conditions: Architect will consider Contractor's request for substitution when the following conditions are satisfied. If the following conditions are not satisfied, Architect will return requests without action, except to record noncompliance with these requirements:

- a. Requested substitution is consistent with the Contract Documents and will produce indicated results.
 - b. Substitution request is fully documented and properly submitted.
 - c. Requested substitution will not adversely affect Contractor's construction schedule.
 - d. Requested substitution has received necessary approvals of authorities having jurisdiction.
 - e. Requested substitution is compatible with other portions of the Work.
 - f. Requested substitution has been coordinated with other portions of the Work.
 - g. Requested substitution provides specified warranty.
 - h. If requested substitution involves more than one contractor, requested substitution has been coordinated with other portions of the Work, is uniform and consistent, is compatible with other products, and is acceptable to all contractors involved.

- B. Substitutions for Convenience: Architect will consider requests for substitution if received within 60 days after the Notice to Proceed Requests received after that time may be considered or rejected at discretion of Architect.

- 1. Conditions: Architect will consider Contractor's request for substitution when the following conditions are satisfied. If the following conditions are not satisfied, Architect will return requests without action, except to record noncompliance with these requirements:

- a. Requested substitution offers Owner a substantial advantage in cost, time, energy conservation, or other considerations, after deducting additional responsibilities Owner must assume. Owner's additional responsibilities may include compensation to Architect for redesign and evaluation services, increased cost of other construction by Owner, and similar considerations.
 - b. Requested substitution does not require extensive revisions to the Contract Documents.
 - c. Requested substitution is consistent with the Contract Documents and will produce indicated results.
 - d. Substitution request is fully documented and properly submitted.
 - e. Requested substitution will not adversely affect Contractor's construction schedule.

- f. Requested substitution has received necessary approvals of authorities having jurisdiction.
- g. Requested substitution is compatible with other portions of the Work.
- h. Requested substitution has been coordinated with other portions of the Work.
- i. Requested substitution provides specified warranty.
- j. If requested substitution involves more than one contractor, requested substitution has been coordinated with other portions of the Work, is uniform and consistent, is compatible with other products, and is acceptable to all contractors involved.

PART 2 - PRODUCTS (Not Used)

PART 3 - EXECUTION (Not Used)

END OF SECTION 012500

SECTION 012600 - CONTRACT MODIFICATION PROCEDURES

PART 1 - GENERAL

1.1 RELATED DOCUMENTS

- A. Drawings and general provisions of the Contract, including General and Supplementary Conditions and other Division 01 Specification Sections, apply to this Section.

1.2 SUMMARY

- A. This Section specifies administrative and procedural requirements for handling and processing Contract modifications.

1.3 MINOR CHANGES IN THE WORK

- A. Architect will issue supplemental instructions authorizing Minor Changes in the Work, not involving adjustment to the Contract Sum or the Contract Time, on AIA Document G710, "Architect's Supplemental Instructions."

1.4 PROPOSAL REQUESTS

- A. Owner-Initiated Proposal Requests: Architect will issue a detailed description of proposed changes in the Work that may require adjustment to the Contract Sum or the Contract Time. If necessary, the description will include supplemental or revised Drawings and Specifications.
 - 1. Proposal Requests issued by Architect are for information only. Do not consider them instructions either to stop work in progress or to execute the proposed change.
 - 2. Within time specified in Proposal Request after receipt of Proposal Request, submit a quotation estimating cost adjustments to the Contract Sum and the Contract Time necessary to execute the change.
 - a. Include a list of quantities of products required or eliminated and unit costs, with total amount of purchases and credits to be made. If requested, furnish survey data to substantiate quantities.
 - b. Indicate applicable taxes, delivery charges, equipment rental, and amounts of trade discounts.
 - c. Include costs of labor and supervision directly attributable to the change.
 - d. Include an updated Contractor's Construction Schedule that indicates the effect of the change, including, but not limited to, changes in activity duration, start and finish times, and activity relationship. Use available total float before requesting an extension of the Contract Time.
- B. Contractor-Initiated Proposals: If latent or unforeseen conditions require modifications to the Contract, Contractor may propose changes by submitting a request for a change to Architect.

1. Include a statement outlining reasons for the change and the effect of the change on the Work. Provide a complete description of the proposed change. Indicate the effect of the proposed change on the Contract Sum and the Contract Time.
 2. Include a list of quantities of products required or eliminated and unit costs, with total amount of purchases and credits to be made. If requested, furnish survey data to substantiate quantities.
 3. Indicate applicable taxes, delivery charges, equipment rental, and amounts of trade discounts.
 4. Include costs of labor and supervision directly attributable to the change.
 5. Include an updated Contractor's Construction Schedule that indicates the effect of the change, including, but not limited to, changes in activity duration, start and finish times, and activity relationship. Use available total float before requesting an extension of the Contract Time.
 6. Comply with requirements in Division 01 Section "Product Requirements" if the proposed change requires substitution of one product or system for product or system specified.
- C. Proposal Request Form: Use AIA Document G709 for Contractor Proposals, initiated proposals.

1.5 CHANGE ORDER PROCEDURES

- A. On Owner's approval of a Proposal Request, Architect will issue a Change Order for signatures of Owner and Contractor on form provided by Owner.

1.6 CONSTRUCTION CHANGE DIRECTIVE

- A. Construction Change Directive: Architect may issue a Construction Change Directive on form provided by Owner. Construction Change Directive instructs Contractor to proceed with a change in the Work, for subsequent inclusion in a Change Order.
1. Construction Change Directive contains a complete description of change in the Work. It also designates method to be followed to determine change in the Contract Sum or the Contract Time.
- B. Documentation: Maintain detailed records on a time and material basis of work required by the Construction Change Directive.
1. After completion of change, submit an itemized account and supporting data necessary to substantiate cost and time adjustments to the Contract.

PART 2 - PRODUCTS (Not Used)

PART 3 - EXECUTION (Not Used)

END OF SECTION 012600

SECTION 012900 - PAYMENT PROCEDURES

PART 1 - GENERAL

1.1 RELATED DOCUMENTS

- A. Drawings and general provisions of the Contract, including General and Supplementary Conditions and other Division 01 Specification Sections, apply to this Section.

1.2 SUMMARY

- A. This Section specifies administrative and procedural requirements necessary to prepare and process Applications for Payment.

1.3 DEFINITIONS

- A. Schedule of Values: A statement furnished by Contractor allocating portions of the Contract Sum to various portions of the Work and used as the basis for reviewing Contractor's Applications for Payment.

1.4 SCHEDULE OF VALUES

- A. Coordination: Coordinate preparation of the Schedule of Values with preparation of Contractor's Construction Schedule.
 - 1. Correlate line items in the Schedule of Values with other required administrative forms and schedules, including the following:
 - a. Application for Payment forms with Continuation Sheets.
 - b. Submittals Schedule.
 - c. Contractor's Construction Schedule.
 - 2. Submit the Schedule of Values to Architect through the Construction Manager at earliest possible date but no later than seven days before the date scheduled for submittal of initial Application for Payment.
- B. Format and Content: Use the Project Manual table of contents as a guide to establish line items for the Schedule of Values. Provide at least one line item for each Specification Section.
 - 1. Identification: Include the following Project identification on the Schedule of Values:
 - a. Project name and location.
 - b. Name of Architect.
 - c. Architect's project number.
 - d. Contractor's name and address.
 - e. Date of submittal.

2. Submit draft of AIA Document G703 Continuation Sheets or other equivalent form approved by Architect and Owner.
3. Arrange the Schedule of Values in tabular form with separate columns to indicate the following for each item listed:
 - a. Related Specification Section or Division.
 - b. Description of the Work.
 - c. Change Orders (numbers) that affect value.
 - 1) Change Orders shall be fully executed with all necessary signatures before they are included in the Schedule of Values.
 - 2) Construction Change Directive cost changes shall be incorporated into fully executed Change Order (s) before they are included in the Schedule of Values.
 - d. Dollar value.
 - 1) Percentage of the Contract Sum to nearest one-hundredth percent, adjusted to total 100 percent.
4. Provide a breakdown of the Contract Sum in enough detail to facilitate continued evaluation of Applications for Payment and progress reports. Coordinate with the Project Manual table of contents. Provide several line items for principal subcontract amounts, where appropriate.
5. Round amounts to nearest whole dollar; total shall equal the Contract Sum.
6. Provide a separate line item in the Schedule of Values for each part of the Work where Applications for Payment may include materials or equipment purchased or fabricated and stored, but not yet installed.
 - a. Differentiate between items stored on-site and items stored off-site. Include evidence of insurance or bonded warehousing.
7. Provide separate line items in the Schedule of Values for initial cost of materials, for each subsequent stage of completion, and for total installed value of that part of the Work.
8. Provide a separate line item for the value of project closeout activities.
9. Each item in the Schedule of Values and Applications for Payment shall be complete. Include total cost and proportionate share of general overhead and profit for each item.
 - a. Temporary facilities and other major cost items that are not direct cost of actual work-in-place may be shown either as separate line items in the Schedule of Values or distributed as general overhead expense, at Contractor's option.
10. Schedule Updating: Update and resubmit the Schedule of Values before the next Applications for Payment when Change Orders or Construction Change Directives result in a change in the Contract Sum.

1.5 APPLICATIONS FOR PAYMENT

- A. Each Application for Payment shall be consistent with previous applications and payments as certified by Architect and Construction Manager and paid for by Owner.

1. Initial Application for Payment, Application for Payment at time of Substantial Completion, and final Application for Payment involve additional requirements.
- B. Payment Application Times: Progress payments shall be submitted to Architect on or before the agreed date of each month. The period covered by each Application for Payment is one month, ending on the last day of the month.
- C. Payment Application Forms: Use AIA Document G702 or other equivalent form approved by Owner, Construction Manager and Architect.
 1. Entries on continuation sheet shall be consistent with approved Schedule of Values.
- D. Application Preparation: Complete every entry on form. Execute by a person authorized to sign legal documents on behalf of Contractor. Architect will return incorrect or incomplete applications without action.
 1. Entries shall match data on the Schedule of Values and Contractor's Construction Schedule. Use updated schedules if revisions were made.
 2. Include amounts of Change Orders issued before last day of construction period covered by application.
- E. Transmittal: Submit one signed original copy of each Application for Payment to Architect by a method ensuring receipt within 24 hours.
 1. Transmit each copy with a transmittal form listing attachments and recording appropriate information about application.
- F. Initial Application for Payment: Administrative actions and submittals that must precede or coincide with submittal of first Application for Payment include the following:
 1. List of subcontractors.
 2. Schedule of Values.
 3. Contractor's Construction Schedule (preliminary if not final).
 4. Products list.
 5. Submittals Schedule (preliminary if not final).
 6. List of Contractor's staff assignments.
 7. List of Contractor's principal consultants.
- G. Application for Payment at Substantial Completion: After issuing the Certificate of Substantial Completion, submit an Application for Payment showing 100 percent completion for portion of the Work claimed as substantially complete, less the value of project closeout activities.
 1. Include documentation supporting claim that the Work is substantially complete and a statement showing an accounting of changes to the Contract Sum.
 2. This application shall reflect Certificates of Partial Substantial Completion issued previously for Owner occupancy of designated portions of the Work.
- H. Final Payment Application: Submit final Application for Payment with releases and supporting documentation not previously submitted and accepted, including, but not limited, to the following on forms acceptable to Owner.

1. Evidence of completion of Project closeout requirements.
2. Contractor's Affidavit of Payment of Debts and Claims.
3. Release of Claims.
4. Consent of Surety to Final Payment.
5. Evidence that claims have been settled.

PART 2 - PRODUCTS (Not Used)

PART 3 - EXECUTION (Not Used)

END OF SECTION 012900

SECTION 013100 - PROJECT MANAGEMENT AND COORDINATION

PART 1 - GENERAL

1.1 RELATED DOCUMENTS

- A. Drawings and general provisions of the Contract, including General and Supplementary Conditions and other Division 1 Specification Sections, apply to this Section.

1.2 CONTRACT DESCRIPTION

- A. This section specifies administrative and supervisory requirements necessary for Project coordination including, but not necessarily limited to:

1. Coordination.
2. Administrative procedures.
3. Organization of construction documents.
4. RFI's (Request for Information)
5. Digital project management procedures.
6. Preconstruction and site mobilization meeting
7. Progress meetings.
8. Preinstallation meeting.
9. General installation provisions.

- B. Related Sections:

1. Section 017300 – Execution Requirements
2. “Individual Bid Packages” for a description of the division of work among separate contracts and coordination activities.
3. Section 017700 – Closeout Procedures for coordinating closeout of the Contract.

1.3 COORDINATION

- A. Coordination: Coordinate construction activities included under various Sections of these Specifications to assure efficient and orderly installation of each part of the Work. Coordinate construction operations included under different Sections of the Specifications that are dependent upon each other for proper installation, connection, and operation.

1. Where installation of one part of the Work is dependent on installation of other components, either before or after its own installation, schedule construction activities in the sequence required to obtain the best results.
2. Where availability of space is limited, coordinate installation of different components to assure maximum accessibility for required maintenance, service and repair.
3. Make adequate provisions to accommodate items scheduled for later installation.
4. In finished areas except as otherwise indicated, conceal pipes, ducts and wiring within the construction. Coordinate locations of fixtures and outlets with finished elements.

- B. Verify utility requirements and characteristics of operating equipment are compatible with building utilities. Coordinate work of various Sections having interdependent responsibilities for installing, connecting to, and placing in service operating equipment.

- C. Coordinate space requirements, supports, and installation of mechanical and electrical work indicated diagrammatically on Drawings. Follow routing shown for pipes, ducts, and conduit as closely as practical; place runs parallel with lines of building. Utilize spaces efficiently to maximize accessibility for other installations, for maintenance, and for repairs.
- D. Where necessary, prepare memoranda for distribution to each party involved outlining special procedures required for coordination. Include such items as required notices, reports, and attendance at meetings.
 - 1. Prepare similar memoranda for the Owner and separate contractors where coordination of their work is required.
- E. Administrative Procedures: Coordinate scheduling and timing of required administrative procedures with other construction activities to avoid conflicts and ensure orderly progress of the Work. Such administrative activities include, but are not limited to, the following:
 - 1. Preparation of schedules.
 - 2. Preparation of schedule of values.
 - 3. Installation and removal of temporary facilities.
 - 4. Delivery and processing of submittals.
 - 5. Progress meetings.
 - 6. Preinstallation conferences.
 - 7. Project close-out activities.
 - 8. Startup and adjustment of systems.
- F. Conservation: Coordinate construction activities to ensure that operations are carried out with consideration given to conservation of energy, water, and materials.
 - 1. Salvage materials and equipment involved in performance of, but not actually incorporated in, the Work. Refer to other Sections for disposition of salvaged materials that are designated as Owner's property.
- G. Division of Specifications and Drawings: The Contract Specifications and Drawings are divided into Sections, and the keynote reference numbers are related to the Specification Section numbering system, for the convenience of the Contractor. These divisions and keynoting systems are not for the purpose of apportioning work or assigning responsibility among subcontractors, suppliers and manufacturers, and shall not relieve the Contractor of the responsibility for fully coordinating the completion of all Work as shown.

1.4 MECHANICAL AND ELECTRICAL COORDINATION

- A. Under the overall direction of the Construction Manager (CMGC), the HVAC Contractor on this project shall assume leadership in the installation coordination of all mechanical subcontract work (plumbing, fire sprinkler, air distribution, sheet metal, insulation, balancing and controls, etc.). The HVAC Contractor shall be responsible for coordination between these trades to make sure that the necessary interface between the different mechanical subs is in place, assuring that installation of the above systems can be installed in a manner that does not jeopardize the proper functioning of other systems, and that the required spacial requirements, clearances, maintenance access, piping gradients, etc. for each of the above systems is provided for and maintained.

B. Coordination of Space:

1. The Project Manager and HVAC contractor shall conduct a mechanical pre-installation conference for the purpose of coordinating the placement, arrangement, and elevation of mechanical equipment, piping systems, cable trays, conduit, etc. in ceilings, chases, and wall cavities. The project Mechanical Engineer and Electrical Contractor shall participate in this meeting along with all applicable mechanical trades.
2. Coordinate use of project space, avoidance of structural and architectural elements, and sequence of installation of fire suppression, plumbing HVAC, communications, security and all other electrical work which is indicated diagrammatically on Drawings. Follow routings shown for pipes, ducts and conduits as closely as practicable, with due allowance for available physical space; make runs parallel with lines of building. Utilize space efficiently to maximize accessibility for other installations, for maintenance and for repairs.
3. In finished areas, except as otherwise shown, conceal pipes, ducts, wiring and the like in the construction, coordinate locations of fixtures and outlets with finish elements.

C. Resolve all “tight” or restricted conditions involving work of various sections in advanced of installation of mechanical and electrical work.

D. Prior to proceeding with work in these areas, Contractor shall be responsible for preparing supplementary drawings for review showing all Work in “tight” areas, and provide minor adjustments and work adjustments as necessary to overcome “tight” conditions, at no increase in Contract Sum. “Tight” areas shall be identified by the Contractor; however, the Owner and Architect reserve the right to require supplementary drawings for any areas materially or visually affected by the construction activity whether or not identified as “tight” by the Contractor. (“Tight” shall be defined here as “a condition so close in structure as to prevent passage; allowing little or no room for free motion or movement, or unable to be concealed by specified finishes .”)

1.5 INTERFERENCES & RIGHT-OF-WAY

- A. Make proper provisions to avoid interferences. Where conflicts occur, architectural and structural has right-of-way over mechanical and electrical work; concealed mechanical work has right-of-way over concealed electrical work; exposed electrical fixtures have right-of-way over mechanical fixtures.
- B. Submit conflicts which cannot be resolved by right-of-way to the A/E for direction.
- C. Submit reflected ceiling coordination plans showing work by all applicable trades for review and approval by the Architect.
- D. Submit wall coordination plans showing work by all applicable trades for review and approval by the Architect.
- E. Submit floor/slab coordination plans showing work by all applicable trades for review and approval by the Architect.

1.6 COORDINATION DRAWINGS

- A. Coordination Drawings, General: Prepare coordination drawings according to requirements in individual Sections, and additionally where installation is not completely indicated on Shop Drawings, where limited space availability necessitates coordination, or if coordination is required to facilitate integration of products and materials fabricated or installed by more than one entity.

- B. The Mechanical/Electrical coordination process shall be performed on site at the Contractor's field office. The following parties shall be directly involved and participate, under the direction of the General Contractor (CMGC), on regularly scheduled weekly basis: Contractor, Plumbing subcontractor, HVAC subcontractor, Fire Protection subcontractor, Electrical subcontractor, Automatic Temperature Control System subcontractor, and Low Voltage Electrical Systems subcontractor. Additional subcontractors and vendors shall participate at various times as required: Masonry and Structural Steel subcontractors, Drywall and Ceiling subcontractors, and others as required.

- C. Each trade's superintendent is expected to participate in the development of coordination drawings. All piping and equipment shall be shown, and all piping greater than 4 inches shall be indicated in double line fashion on the coordination drawings.
 - 1. Content: Project-specific information, drawn accurately to a scale large enough to indicate and resolve conflicts. Do not base coordination drawings on standard printed data. Include the following information, as applicable:
 - a. Use applicable Drawings as a basis for preparation of coordination drawings. Prepare sections, elevations, and details as needed to describe relationship of various systems and components.
 - b. Coordinate the addition of trade-specific information to coordination drawings in a sequence that best provides for coordination of the information and resolution of conflicts between installed components before submitting for review.
 - c. Indicate functional and spatial relationships of components of architectural, structural, civil, mechanical, and electrical systems.
 - d. Indicate space requirements for routine maintenance and for anticipated replacement of components during the life of the installation.
 - e. Show location and size of access doors required for access to concealed dampers, valves, and other controls.
 - f. Indicate required installation sequences.
 - g. Indicate dimensions shown on Drawings. Specifically note dimensions that appear to be in conflict with submitted equipment and minimum clearance requirements. Provide alternative sketches to Architect indicating proposed resolution of such conflicts. Minor dimension changes and difficult installations will not be considered changes to the Contract.

1.7 REQUEST FOR INFORMATION (RFI)

- A. General: Immediately on discovery of the need for additional information, clarification, or interpretation of the Contract Documents, Contractor shall prepare and submit an RFI in the form specified to the Construction Manager.
 - 1. Architect will return without response those RFIs submitted to Architect by other entities controlled by Contractor.
 - 2. Coordinate and submit RFIs in a prompt manner so as to avoid delays in Contractor's work or work of subcontractors.

- B. Content of the RFI: Include a detailed, legible description of item needing information or interpretation and the following:
 - 1. Project name.
 - 2. Project number.
 - 3. Date.
 - 4. Name of Contractor.
 - 5. Name of Architect and Construction Manager.
 - 6. RFI number, numbered sequentially.
 - 7. RFI subject.
 - 8. Specification Section number and title and related paragraphs, as appropriate.
 - 9. Drawing number and detail references, as appropriate.
 - 10. Field dimensions and conditions, as appropriate.
 - 11. Contractor's suggested resolution. If Contractor's suggested resolution impacts the Contract Time or the Contract Sum, Contractor shall state impact in the RFI.
 - 12. Contractor's signature.
 - 13. Attachments: Include sketches, descriptions, measurements, photos, Product Data, Shop Drawings, coordination drawings, and other information necessary to fully describe items needing interpretation.
 - a. Include dimensions, thicknesses, structural grid references, and details of affected materials, assemblies, and attachments on attached sketches.

- C. RFI Forms: AIA Document G716 or a Software-generated form with substantially the same content as indicated above, acceptable to Architect.
 - 1. Attachments shall be electronic files in PDF format.

- D. Architect's and Construction Manager's Action: Architect and Construction Manager will review each RFI, determine action required, and respond. Allow seven working days for Architect's response for each RFI.
 - 1. The following Contractor-generated RFIs will be returned without action:
 - a. Requests for approval of submittals.
 - b. Requests for approval of substitutions.
 - c. Requests for approval of Contractor's means and methods.
 - d. Requests for coordination information already indicated in the Contract Documents.
 - e. Requests for adjustments in the Contract Time or the Contract Sum.
 - f. Requests for interpretation of Architect's actions on submittals.
 - g. Incomplete RFIs or inaccurately prepared RFIs.

2. Architect's action may include a request for additional information, in which case Architect's time for response will date from time of receipt by Architect or Construction Manager of additional information.
 3. Architect's action on RFIs that may result in a change to the Contract Time or the Contract Sum may be eligible for Contractor to submit Change Proposal.
 - a. If Contractor believes the RFI response warrants change in the Contract Time or the Contract Sum, notify Architect and Construction Manager in writing within 10 days of receipt of the RFI response.
- E. RFI Log: Prepare, maintain, and submit a tabular log of RFIs organized by the RFI number.

1.8 DIGITAL PROJECT MANAGEMENT PROCEDURES

- A. Use of Architect's Digital Data Files: Digital data files of Architect's CAD drawings will be provided by Architect for Contractor's use during construction.
1. Digital data files may be used by Contractor in preparing coordination drawings, Shop Drawings, and Project record Drawings.
 2. Architect makes no representations as to the accuracy or completeness of digital data files as they relate to Contract Drawings.
 3. Contractor shall execute a data licensing agreement in the form of AIA Document C106 Digital Data Licensing Agreement
 - a. Subcontractors, and other parties granted access by Contractor to Architect's digital data files shall execute a data licensing agreement in the form of AIA Document C106.
- B. Web-Based Project Software: Use Construction Manager's web-based Project software site "Procore" or similar software for purposes of hosting and managing Project communication and documentation until Final Completion.
1. Web-based Project software site includes, at a minimum, the following features:
 - a. Compilation of Project data, including Contractor, subcontractors, Architect, architect's consultants, Owner, and other entities involved in Project. Include names of individuals and contact information.
 - b. Access control for each entity for each workflow process, to determine entity's digital rights to create, modify, view, and print documents.
 - c. Document workflow planning, allowing customization of workflow between project entities.
 - d. Creation, logging, tracking, and notification for Project communications required in other Specification Sections, including, but not limited to, RFIs, submittals, Minor Changes in the Work, Construction Change Directives, and Change Orders.
 - e. Track status of each Project communication in real time, and log time and date when responses are provided.
 - f. Procedures for handling PDFs or similar file formats, allowing markups by each entity. Provide security features to lock markups against changes once submitted.
 - g. Processing and tracking of payment applications.
 - h. Processing and tracking of contract modifications.
 - i. Creating and distributing meeting minutes.

- j. Document management for Drawings, Specifications, and coordination drawings, including revision control.
 - k. Management of construction progress photographs.
 - l. Mobile device compatibility, including smartphones and tablets.
- C. PDF Document Preparation: Where PDFs are required to be submitted to Architect, prepare as follows:
- 1. Assemble complete submittal package into a single indexed file incorporating submittal requirements of a single Specification Section and transmittal form with links enabling navigation to each item.
 - 2. Name file with submittal number or other unique identifier, including revision identifier.
 - 3. Certifications: Where digitally submitted certificates and certifications are required, provide a digital signature with digital certificate on where indicated.

1.9 PRECONSTRUCTION AND SITE MOBILIZATION MEETING

- A. The Construction Manager will schedule meeting after Notice of Award.
- B. Approved safety programs must be submitted and on site prior to mobilizing.
- C. Attendance Required: Owner, Architect, Construction Manager, special consultants, Contractor, Contractor's superintendent, and major subcontractors.
- D. Agenda:
 - 1. Introduction of personnel representing the parties in Contract.
 - 2. Use of premises by Owner and Contractor.
 - 3. Owner's requirements and partial occupancy.
 - 4. Construction facilities and controls provided by Owner.
 - 5. Temporary utilities provided by Owner
 - 6. Survey and building layout.
 - 7. Security and housekeeping procedures.
 - 8. Submission of schedule of values and progress schedule.
 - 9. Procedures and processing of field decisions, submittals, substitutions, applications for payments, proposal request, Change Orders, and Contract closeout procedures.
 - 10. Procedures for testing.
 - 11. Procedures for maintaining record documents.
 - 12. Requirements for start-up of equipment.
 - 13. Inspection and acceptance of equipment put into service during construction period.
- E. Construction Manager will record minutes and distribute copies within two days after Meeting to participants, with copies to Architect, Owner, and those affected by decisions made.

1.10 PROGRESS MEETINGS

- A. Schedule and administer meetings throughout progress of the Work at monthly intervals, or more frequently if deemed necessary.
- B. Construction Manager will make arrangements for meetings, prepare agenda with copies for participants, and preside at meetings.
- C. Attendance Required: Job Superintendent, major contractors and suppliers, Owner,

Architect/Engineers, and Construction Manager, as appropriate to agenda topics for each meeting.

D. Agenda:

1. Review of Work completed and progress “job walk”.
2. Review minutes of previous meetings.
3. Review of Work progress.
4. Field observations, problems, and decisions.
5. Identification of problems impending planned progress.
6. Review of submittals schedule and status of submittals.
7. Review of off-site fabrication and delivery schedules.
8. Maintenance of progress schedule.
9. Corrective measures to regain projected schedules.
10. Planned progress during succeeding work period.
11. Coordination of projected progress.
12. Maintenance of quality and work standards.
13. Effect of proposed changes on progress schedule and coordination.
14. Other business relating to Work.
15. Schedule next meeting.

- E. Construction Manager will record minutes and distribute copies within two days after meeting to participants, with copies to Architect, Owner, and those affected by decisions made.

1.11 PREINSTALLATION MEETINGS

- A. Building Façade Meeting: Convene a preinstallation meeting at work site 2 weeks prior to commencing work related to the exterior “envelope” of the building. These elements include the exterior wall finish materials, roofing, flashings, control joints, expansion joints, decking details, all roof and wall penetrations. The Contractor shall prepare the appropriate details and shop drawings illustrating compliance with the Construction Documents. The Contractor shall submit these drawings/submittals to the Architect at least 2 weeks prior to this meeting.
- B. When required in individual Specification Sections, convene preinstallation meeting at Project site prior to commencing work of specific Section.
- C. Require attendance of parties directly affecting, or affected by, work of specific Sections.
- D. Notify Architect 14 days in advance of meeting date.
- E. Prepare agenda and preside at meeting.
1. Review conditions of installation, preparation, and installation procedures.
 2. Review coordination with related work.
- F. Record minutes and distributes copies within two days after meeting to participants, with copies to Architect, Owner, and those affected by decisions made.

PART 2 – PRODUCTS (Not Applicable)

PART 3 – EXECUTION

3.1 GENERAL INSTALLATION PROVISIONS.

- A. Inspection of Conditions: Require the installer of each major component to inspect both the substrate and conditions under which Work is to be performed. Do not proceed until unsatisfactory conditions have been corrected in an acceptable manner.
- B. Manufacturer's Instructions: Comply with manufacturer's installation instructions and recommendations, to the extent that those instructions and recommendations are more explicit or stringent than requirements contained in Contract Documents.
- C. Inspect materials or equipment immediately upon delivery and again prior to installation. Reject damaged and defective items.
- D. Visual Effects: Provide uniform joint widths in exposed Work. Arrange joints in exposed Work to obtain the best visual effect. Refer questionable choices to the Architect for final decision.
- E. Recheck measurements and dimensions before starting each installation.
- F. Install each component during weather conditions and Project status that will ensure the best possible results. Isolate each part of the completed construction from incompatible material as necessary to prevent deterioration.
- G. Close openings in exterior surfaces to protect installed work from weather and extremes of temperature and humidity.
- H. Coordinate temporary enclosures with required inspections and tests, to minimize the necessity of uncovering completed construction for that purpose.

END OF SECTION 013100

THIS PAGE INTENTIONALLY BLANK

SECTION 013300 - SUBMITTAL PROCEDURES

PART 1 - GENERAL

1.1 RELATED DOCUMENTS

- A. Drawings and general provisions of the Contract, including General and Supplementary Conditions and other Division 01 Specification Sections, apply to this Section.

1.2 SUMMARY

- A. Section Includes:
 - 1. Submittal schedule requirements.
 - 2. Administrative and procedural requirements for submittals.

1.3 SUBMITTAL SCHEDULE

- A. Submittal Schedule: Submit, as an action submittal, a list of submittals, arranged in chronological order by dates required by construction schedule. Include time required for review, ordering, manufacturing, fabrication, and delivery when establishing dates. Include additional time required for making corrections or revisions to submittals noted by Architect and Construction Manager and additional time for handling and reviewing submittals required by those corrections.
 - 1. Coordinate submittal schedule with list of subcontracts, the schedule of values, and Contractor's construction schedule.
 - 2. Initial Submittal: Submit concurrently with startup construction schedule. Include submittals required during the first 60 days of construction. List those submittals required to maintain orderly progress of the Work and those required early because of long lead time for manufacture or fabrication.
 - 3. Final Submittal: Submit concurrently with the first complete submittal of Contractor's construction schedule.
 - a. Submit revised submittal schedule to reflect changes in current status and timing for submittals.
 - 4. Format: Arrange the following information in a tabular format:
 - a. Scheduled date for first submittal.
 - b. Specification Section number and title.
 - c. Submittal Category: Action; informational.
 - d. Name of subcontractor.
 - e. Description of the Work covered.
 - f. Scheduled date for Architect and Construction Manager final release or approval.
 - g. Scheduled dates for purchasing.
 - h. Scheduled date of fabrication.

- i. Scheduled dates for installation.
- j. Activity or event number.

1.4 SUBMITTAL FORMATS

A. Submittal Information: Include the following information in each submittal:

- 1. Project name.
- 2. Date.
- 3. Name of Architect.
- 4. Name of Construction Manager.
- 5. Name of Contractor.
- 6. Name of firm or entity that prepared submittal.
- 7. Names of subcontractor, manufacturer, and supplier.
- 8. Unique submittal number, including revision identifier. Include Specification Section number with sequential alphanumeric identifier; and alphanumeric suffix for resubmittals.
- 9. Category and type of submittal.
- 10. Submittal purpose and description.
- 11. Number and title of Specification Section, with paragraph number and generic name for each of multiple items.
- 12. Drawing number and detail references, as appropriate.
- 13. Indication of full or partial submittal.
- 14. Location(s) where product is to be installed, as appropriate.
- 15. Other necessary identification.
- 16. Remarks.
- 17. Signature of transmitter.

B. Options: Identify options requiring selection by Architect.

C. Deviations and Additional Information: On each submittal, clearly indicate deviations from requirements in the Contract Documents, including minor variations and limitations; include relevant additional information and revisions, other than those requested by Architect and Construction Manager on previous submittals. Indicate by highlighting on each submittal or noting on attached separate sheet.

D. PDF Submittals: Prepare submittals as PDF package, incorporating complete information into each PDF file. Name PDF file with submittal number.

E. Submittals for Web-Based Project Software: Prepare submittals as PDF files, or other format indicated by Project software website.

1.5 SUBMITTAL PROCEDURES

A. Prepare and submit submittals required by individual Specification Sections. Types of submittals are indicated in individual Specification Sections.

1. Web-Based Project Software: Prepare submittals in PDF form, and upload to web-based Project software website. Enter required data in web-based software site to fully identify submittal.
- B. Coordination: Coordinate preparation and processing of submittals with performance of construction activities.
 1. Coordinate each submittal with fabrication, purchasing, testing, delivery, other submittals, and related activities that require sequential activity.
 2. Submit all submittal items required for each Specification Section concurrently unless partial submittals for portions of the Work are indicated on approved submittal schedule.
 3. Submit action submittals and informational submittals required by the same Specification Section as separate packages under separate transmittals.
 4. Coordinate transmittal of submittals for related parts of the Work specified in different Sections so processing will not be delayed because of need to review submittals concurrently for coordination.
 - a. Architect and Construction Manager reserve the right to withhold action on a submittal requiring coordination with other submittals until related submittals are received.
- C. Processing Time: Allow time for submittal review, including time for resubmittals, as follows. Time for review shall commence on Architect's receipt of submittal. No extension of the Contract Time will be authorized because of failure to transmit submittals enough in advance of the Work to permit processing, including resubmittals.
 1. Initial Review: Allow 15 days for initial review of each submittal. Allow additional time if coordination with subsequent submittals is required.
 2. Resubmittal Review: Allow 7 days for review of each resubmittal.
 3. Sequential Review: Where sequential review of submittals by Architect's consultants, Owner, or other parties is indicated, allow 21 days for initial review of each submittal.
 4. Concurrent Consultant Review: Where the Contract Documents indicate that submittals may be transmitted simultaneously to Architect and to Architect's consultants, allow 15 days for review of each submittal.
- D. Resubmittals: Make resubmittals in same form and number of copies as initial submittal.
- E. Distribution: Furnish copies of final submittals to manufacturers, subcontractors, suppliers, fabricators, installers, authorities having jurisdiction, and others as necessary for performance of construction activities. Show distribution on transmittal forms.
- F. Use for Construction: Retain complete copies of submittals on Project site. Use only final action submittals that are marked with approval notation from Architect and Construction Manager action stamp.

1.6 SUBMITTAL REQUIREMENTS

- A. Product Data: Collect information into a single submittal for each element of construction and type of product or equipment.

1. If information must be specially prepared for submittal because standard published data are unsuitable for use, submit as Shop Drawings, not as Product Data.
 2. Mark each copy of each submittal to show which products and options are applicable.
 3. Include the following information, as applicable:
 - a. Manufacturer's catalog cuts.
 - b. Manufacturer's product specifications.
 - c. Standard color charts.
 - d. Statement of compliance with specified referenced standards.
 - e. Testing by recognized testing agency.
 - f. Application of testing agency labels and seals.
 - g. Notation of coordination requirements.
 - h. Availability and delivery time information.
 4. For equipment, include the following in addition to the above, as applicable:
 - a. Wiring diagrams that show factory-installed wiring.
 - b. Printed performance curves.
 - c. Operational range diagrams.
 - d. Clearances required to other construction, if not indicated on accompanying Shop Drawings.
 5. Submit Product Data before Shop Drawings, and before or concurrent with Samples.
- B. Shop Drawings: Prepare Project-specific information, drawn accurately to scale. Do not base Shop Drawings on reproductions of the Contract Documents or standard printed data unless submittal based on Architect's digital data drawing files is otherwise permitted.
1. Preparation: Fully illustrate requirements in the Contract Documents. Include the following information, as applicable:
 - a. Identification of products.
 - b. Schedules.
 - c. Compliance with specified standards.
 - d. Notation of coordination requirements.
 - e. Notation of dimensions established by field measurement.
 - f. Relationship and attachment to adjoining construction clearly indicated.
 - g. Seal and signature of professional engineer if specified.
 2. Paper Sheet Size: Except for templates, patterns, and similar full-size Drawings, submit Shop Drawings on sheets at least 8-1/2 by 11 inches (215 by 280 mm), but no larger than 30 by 42 inches (750 by 1067 mm).
- C. Samples: Submit Samples for review of kind, color, pattern, and texture for a check of these characteristics with other materials.
1. Transmit Samples that contain multiple, related components such as accessories together in one submittal package.
 2. Identification: Permanently attach label on unexposed side of Samples that includes the following:

- a. Project name and submittal number.
 - b. Generic description of Sample.
 - c. Product name and name of manufacturer.
 - d. Sample source.
 - e. Number and title of applicable Specification Section.
 - f. Specification paragraph number and generic name of each item.
3. Email Transmittal: Provide PDF transmittal. Include digital image file illustrating Sample characteristics, and identification information for record.
 4. Web-Based Project Software: Prepare submittals in PDF form, and upload to web-based Project software website. Enter required data in web-based software site to fully identify submittal.
 5. Disposition: Maintain sets of approved Samples at Project site, available for quality-control comparisons throughout the course of construction activity. Sample sets may be used to determine final acceptance of construction associated with each set.
 - a. Samples that may be incorporated into the Work are indicated in individual Specification Sections. Such Samples must be in an undamaged condition at time of use.
 - b. Samples not incorporated into the Work, or otherwise designated as Owner's property, are the property of Contractor.
 6. Samples for Initial Selection: Submit manufacturer's physical color charts consisting of units or sections of units showing the full range of colors, textures, and patterns available.
 - a. Number of Samples: Submit one full physical set of available choices where color, pattern, texture, or similar characteristics are required to be selected from manufacturer's product line. Architect will return submittal with options selected.
 7. Samples for Verification: Submit full-size physical units or physical samples of size indicated, prepared from same material to be used for the Work, cured and finished in manner specified, and physically identical with material or product proposed for use, and that show full range of color and texture variations expected. Samples include, but are not limited to, the following: partial sections of manufactured or fabricated components; small cuts or containers of materials; complete units of repetitively used materials; swatches showing color, texture, and pattern; color range sets; and components used for independent testing and inspection.
 - a. Number of Samples: Submit two sets of Samples. Architect and Construction Manager will retain one Sample set; remainder will be returned.
 - 1) Submit a single Sample where assembly details, workmanship, fabrication techniques, connections, operation, and other similar characteristics are to be demonstrated.
 - 2) If variation in color, pattern, texture, or other characteristic is inherent in material or product represented by a Sample, submit samples that show approximate limits of variations.
- D. Product Schedule: As required in individual Specification Sections, prepare a written summary indicating types of products required for the Work and their intended location. Include the following information in tabular form:

1. Type of product. Include unique identifier for each product indicated in the Contract Documents or assigned by Contractor if none is indicated.
 2. Manufacturer and product name, and model number if applicable.
 3. Number and name of room or space.
 4. Location within room or space.
- E. Qualification Data: Prepare written information that demonstrates capabilities and experience of firm or person. Include lists of completed projects with project names and addresses, contact information of architects and owners, and other information specified.
- F. Design Data: Prepare and submit written and graphic information indicating compliance with indicated performance and design criteria in individual Specification Sections. Include list of assumptions and summary of loads. Include load diagrams if applicable. Provide name and version of software, if any, used for calculations. Number each page of submittal.
- G. Certificates:
1. Certificates and Certifications Submittals: Submit a statement that includes signature of entity responsible for preparing certification. Certificates and certifications shall be signed by an officer or other individual authorized to sign documents on behalf of that entity. Provide a notarized signature where indicated.
 2. Installer Certificates: Submit written statements on manufacturer's letterhead certifying that Installer complies with requirements in the Contract Documents and, where required, is authorized by manufacturer for this specific Project.
 3. Manufacturer Certificates: Submit written statements on manufacturer's letterhead certifying that manufacturer complies with requirements in the Contract Documents. Include evidence of manufacturing experience where required.
 4. Material Certificates: Submit written statements on manufacturer's letterhead certifying that material complies with requirements in the Contract Documents.
 5. Product Certificates: Submit written statements on manufacturer's letterhead certifying that product complies with requirements in the Contract Documents.
 6. Welding Certificates: Prepare written certification that welding procedures and personnel comply with requirements in the Contract Documents. Submit record of Welding Procedure Specification and Procedure Qualification Record on AWS forms. Include names of firms and personnel certified.
- H. Test and Research Reports:
1. Compatibility Test Reports: Submit reports written by a qualified testing agency, on testing agency's standard form, indicating and interpreting results of compatibility tests performed before installation of product. Include written recommendations for primers and substrate preparation needed for adhesion.
 2. Field Test Reports: Submit written reports indicating and interpreting results of field tests performed either during installation of product or after product is installed in its final location, for compliance with requirements in the Contract Documents.
 3. Material Test Reports: Submit reports written by a qualified testing agency, on testing agency's standard form, indicating and interpreting test results of material for compliance with requirements in the Contract Documents.
 4. Preconstruction Test Reports: Submit reports written by a qualified testing agency, on testing agency's standard form, indicating and interpreting results of tests performed

before installation of product, for compliance with performance requirements in the Contract Documents.

5. Product Test Reports: Submit written reports indicating that current product produced by manufacturer complies with requirements in the Contract Documents. Base reports on evaluation of tests performed by manufacturer and witnessed by a qualified testing agency, or on comprehensive tests performed by a qualified testing agency.
6. Research Reports: Submit written evidence, from a model code organization acceptable to authorities having jurisdiction, that product complies with building code in effect for Project. Include the following information:
 - a. Name of evaluation organization.
 - b. Date of evaluation.
 - c. Time period when report is in effect.
 - d. Product and manufacturers' names.
 - e. Description of product.
 - f. Test procedures and results.
 - g. Limitations of use.

1.7 DELEGATED-DESIGN SERVICES

- A. Performance and Design Criteria: Where professional design services or certifications by a design professional are specifically required of Contractor by the Contract Documents, provide products and systems complying with specific performance and design criteria indicated.
 1. If criteria indicated are insufficient to perform services or certification required, submit a written request for additional information to Architect.
- B. Delegated-Design Services Certification: In addition to Shop Drawings, Product Data, and other required submittals, submit digitally signed PDF file copies of certificate, signed and sealed by the responsible design professional, for each product and system specifically assigned to Contractor to be designed or certified by a design professional.
 1. Indicate that products and systems comply with performance and design criteria in the Contract Documents. Include list of codes, loads, and other factors used in performing these services.

1.8 CONTRACTOR'S REVIEW

- A. Action Submittals and Informational Submittals: Review each submittal and check for coordination with other Work of the Contract and for compliance with the Contract Documents. Note corrections and field dimensions. Mark with approval stamp before submitting to Architect.
- B. Contractor's Approval: Indicate Contractor's approval for each submittal with or indication in web-based Project software. Include name of reviewer, date of Contractor's approval, and statement certifying that submittal has been reviewed, checked, and approved for compliance with the Contract Documents.

1.9 ARCHITECT'S AND CONSTRUCTION MANAGER'S REVIEW

- A. Action Submittals: Architect and Construction Manager will review each submittal, indicate corrections or revisions required.
 - 1. PDF Submittals: Architect and Construction Manager will indicate, via markup on each submittal, the appropriate action.
 - 2. Submittals by Web-Based Project Software: Architect and Construction Manager will indicate, on Project software website, the appropriate action.
- B. Informational Submittals: Architect and Construction Manager will review each submittal and will not return it, or will return it if it does not comply with requirements. Architect and Construction Manager will forward each submittal to appropriate party.
- C. Partial submittals prepared for a portion of the Work will be reviewed when use of partial submittals has received prior approval from Architect and Construction Manager.
- D. Incomplete submittals are unacceptable, will be considered nonresponsive, and will be returned for resubmittal without review.
- E. Architect and Construction Manager will return without review submittals received from sources other than Contractor.
- F. Submittals not required by the Contract Documents will be returned by Architect without action.

PART 2 - PRODUCTS (Not Used)

PART 3 - EXECUTION (Not Used)

END OF SECTION 013300

SECTION 014000 - QUALITY REQUIREMENTS

PART 1 - GENERAL

1.1 RELATED DOCUMENTS

- A. Drawings and general provisions of the Contract, including General and Supplementary Conditions and other Division 01 Specification Sections, apply to this Section.

1.2 SUMMARY

- A. This Section includes administrative and procedural requirements for quality assurance and quality control.
- B. Testing and inspecting services are required to verify compliance with requirements specified or indicated. These services do not relieve Contractor of responsibility for compliance with the Contract Document requirements.
 - 1. Specific quality-assurance and -control requirements for individual construction activities are specified in the Sections that specify those activities. Requirements in those Sections may also cover production of standard products.
 - 2. Specified tests, inspections, and related actions do not limit Contractor's other quality-assurance and -control procedures that facilitate compliance with the Contract Document requirements.
 - 3. Requirements for Contractor to provide quality-assurance and -control services required by Architect, Owner, or authorities having jurisdiction are not limited by provisions of this Section.

1.3 DEFINITIONS

- A. Quality-Assurance Services: Activities, actions, and procedures performed before and during execution of the Work to guard against defects and deficiencies and substantiate that proposed construction will comply with requirements.
- B. Quality-Control Services: Tests, inspections, procedures, and related actions during and after execution of the Work to evaluate that actual products incorporated into the Work and completed construction comply with requirements. Services do not include contract enforcement activities performed by Architect
- C. Mockups: Full-size, physical assemblies that are constructed on-site. Mockups are used to verify selections made under sample submittals, to demonstrate aesthetic effects and, where indicated, qualities of materials and execution, and to review construction, coordination, testing, or operation; they are not Samples. Approved mockups establish the standard by which the Work will be judged.
- D. Laboratory Mockups: Full-size, physical assemblies that are constructed at testing facility to verify performance characteristics.

- E. Preconstruction Testing: Tests and inspections that are performed specifically for the Project before products and materials are incorporated into the Work to verify performance or compliance with specified criteria.
- F. Product Testing: Tests and inspections that are performed by an NRTL, an NVLAP, or a testing agency qualified to conduct product testing and acceptable to authorities having jurisdiction, to establish product performance and compliance with industry standards.
- G. Source Quality-Control Testing: Tests and inspections that are performed at the source, i.e., plant, mill, factory, or shop.
- H. Field Quality-Control Testing: Tests and inspections that are performed on-site for installation of the Work and for completed Work.
- I. Testing Agency: An entity engaged to perform specific tests, inspections, or both. Testing laboratory shall mean the same as testing agency.
- J. Installer/Applicator/Erector: Contractor or another entity engaged by Contractor as an employee, Subcontractor, or Sub-subcontractor, to perform a particular construction operation, including installation, erection, application, and similar operations.
 - 1. Using a term such as "carpentry" does not imply that certain construction activities must be performed by accredited or unionized individuals of a corresponding generic name, such as "carpenter." It also does not imply that requirements specified apply exclusively to trades people of the corresponding generic name.
- K. Experienced: When used with an entity, "experienced" means having successfully completed a minimum of five previous projects similar in size and scope to this Project; being familiar with special requirements indicated; and having complied with requirements of authorities having jurisdiction.

1.4 CONFLICTING REQUIREMENTS

- A. General: If compliance with two or more standards is specified and the standards establish different or conflicting requirements for minimum quantities or quality levels, comply with the most stringent requirement. Refer uncertainties and requirements that are different, but apparently equal, to Architect for a decision before proceeding.
- B. Minimum Quantity or Quality Levels: The quantity or quality level shown or specified shall be the minimum provided or performed. The actual installation may comply exactly with the minimum quantity or quality specified, or it may exceed the minimum within reasonable limits. To comply with these requirements, indicated numeric values are minimum or maximum, as appropriate, for the context of requirements. Refer uncertainties to Architect for a decision before proceeding.

1.5 SUBMITTALS

- A. Qualification Data: For testing agencies specified in "Quality Assurance" Article to demonstrate their capabilities and experience. Include proof of qualifications in the form of a recent report on the inspection of the testing agency by a recognized authority.
- B. Reports: Prepare and submit certified written reports FOR contractor provided tests and inspections that include the following:
 - 1. Date of issue.
 - 2. Project title and number.
 - 3. Name, address, and telephone number of testing agency.
 - 4. Dates and locations of samples and tests or inspections.
 - 5. Names of individuals making tests and inspections.
 - 6. Description of the Work and test and inspection method.
 - 7. Identification of product and Specification Section.
 - 8. Complete test or inspection data.
 - 9. Test and inspection results and an interpretation of test results.
 - 10. Record of temperature and weather conditions at time of sample taking and testing and inspecting.
 - 11. Comments or professional opinion on whether tested or inspected Work complies with the Contract Document requirements.
 - 12. Name and signature of laboratory inspector.
 - 13. Recommendations on retesting and reinspecting.
- C. Permits, Licenses, and Certificates: For Owner's records, submit copies of permits, licenses, certifications, inspection reports, releases, jurisdictional settlements, notices, receipts for fee payments, judgments, correspondence, records, and similar documents, established for compliance with standards and regulations bearing on performance of the Work.

1.6 QUALITY ASSURANCE

- A. General: Qualifications paragraphs in this Article establish the minimum qualification levels required; individual Specification Sections specify additional requirements.
- B. Installer Qualifications: A firm or individual experienced in installing, erecting, or assembling work similar in material, design, and extent to that indicated for this Project, whose work has resulted in construction with a record of successful in-service performance.
- C. Manufacturer Qualifications: A firm experienced in manufacturing products or systems similar to those indicated for this Project and with a record of successful in-service performance, as well as sufficient production capacity to produce required units.
- D. Fabricator Qualifications: A firm experienced in producing products similar to those indicated for this Project and with a record of successful in-service performance, as well as sufficient production capacity to produce required units.

- E. Professional Engineer Qualifications: A professional engineer who is legally qualified to practice in jurisdiction where Project is located and who is experienced in providing engineering services of the kind indicated. Engineering services are defined as those performed for installations of the system, assembly, or product that are similar to those indicated for this Project in material, design, and extent.
- F. Specialists: Certain sections of the Specifications require that specific construction activities shall be performed by entities who are recognized experts in those operations. Specialists shall satisfy qualification requirements indicated and shall be engaged for the activities indicated.
 - 1. Requirement for specialists shall not supersede building codes and regulations governing the Work.
- G. Testing Agency Qualifications: An independent agency with the experience and capability to conduct testing and inspecting indicated, as documented according to ASTM E 548; and with additional qualifications specified in individual Sections; and where required by authorities having jurisdiction, that is acceptable to authorities.
- H. Factory-Authorized Service Representative Qualifications: An authorized representative of manufacturer who is trained and approved by manufacturer to inspect installation of manufacturer's products that are similar in material, design, and extent to those indicated for this Project.
- I. Preconstruction Testing: Where testing agency is indicated to perform preconstruction testing for compliance with specified requirements for performance and test methods, comply with the following:
 - 1. Contractor responsibilities include the following:
 - a. Provide test specimens representative of proposed products and construction.
 - b. Submit specimens in a timely manner with sufficient time for testing and analyzing results to prevent delaying the Work.
 - c. Provide sizes and configurations of test assemblies, mockups, and laboratory mockups to adequately demonstrate capability of products to comply with performance requirements.
 - d. Build site-assembled test assemblies and mockups using installers who will perform same tasks for Project.
 - e. Build laboratory mockups at testing facility using personnel, products, and methods of construction indicated for the completed Work.
 - f. When testing is complete, remove test specimens, assemblies, mockups, and laboratory mockups; do not reuse products on Project.
 - 2. Testing Agency Responsibilities: Submit a certified written report of each test, inspection, and similar quality-assurance service to Architect, Owner, and Contractor. Interpret tests and inspections and state in each report whether tested and inspected work complies with or deviates from the Contract Documents.
- J. Mockups: Before installing portions of the Work requiring mockups, build mockups for each form of construction and finish required to comply with the following requirements, using materials indicated for the completed Work:
 - 1. Build mockups in location and of size indicated or, if not indicated, as directed by Architect.

2. Notify Architect ten days in advance of dates and times when mockups will be constructed.
3. Demonstrate the proposed range of aesthetic effects and workmanship.
4. Obtain Architect's approval of mockups before starting work, fabrication, or construction.
 - a. Allow ten days for initial review and each re-review of each mockup.
5. Maintain mockups during construction in an undisturbed condition as a standard for judging the completed Work.
6. Demolish and remove mockups when directed, unless otherwise indicated.

1.7 QUALITY CONTROL

- A. Owner Responsibilities: Where quality-control services are indicated as Owner's responsibility, Owner will engage a qualified testing agency to perform these services.
 1. Owner will furnish Contractor with names, addresses, and telephone numbers of testing agencies engaged and a description of types of testing and inspecting they are engaged to perform.
 2. Payment for these services will be made from testing and inspecting allowances, as authorized by Change Orders.
 3. Costs for retesting and reinspecting construction that replaces or is necessitated by work that failed to comply with the Contract Documents will be charged to Contractor.
- B. Tests and inspections not explicitly assigned to Owner are Contractor's responsibility. Unless otherwise indicated, provide quality-control services specified and those required by authorities having jurisdiction. Perform quality-control services required of Contractor by authorities having jurisdiction, whether specified or not.
 1. Where services are indicated as Contractor's responsibility, engage a qualified testing agency to perform these quality-control services.
 - a. Contractor's testing agency shall be acceptable to Owner and Architect.
 - b. Contractor shall not employ same entity engaged by Owner, unless agreed to in writing by Owner.
 2. Notify testing agencies at least 24 hours in advance of time when Work that requires testing or inspecting will be performed.
 3. Where quality-control services are indicated as Contractor's responsibility, submit a certified written report, in duplicate, of each quality-control service.
 4. Testing and inspecting requested by Contractor and not required by the Contract Documents are Contractor's responsibility.
 5. Submit additional copies of each written report directly to authorities having jurisdiction, when they so direct.
- C. Manufacturer's Field Services: Where indicated, engage a factory-authorized service representative to inspect field-assembled components and equipment installation, including service connections. Report results in writing as specified in Division 01 Section "Submittal Procedures."

- D. Retesting/Reinspecting: Regardless of whether original tests or inspections were Contractor's responsibility, provide quality-control services, including retesting and reinspecting, for construction that replaced Work that failed to comply with the Contract Documents.
- E. Testing Agency Responsibilities: Cooperate with Architect and Contractor in performance of duties. Provide qualified personnel to perform required tests and inspections.
 - 1. Notify Architect and Contractor promptly of irregularities or deficiencies observed in the Work during performance of its services.
 - 2. Determine the location from which test samples will be taken and in which in-situ tests are conducted.
 - 3. Conduct and interpret tests and inspections and state in each report whether tested and inspected work complies with or deviates from requirements.
 - 4. Submit a certified written report, in duplicate, of each test, inspection, and similar quality-control service through Contractor.
 - 5. Do not release, revoke, alter, or increase the Contract Document requirements or approve or accept any portion of the Work.
 - 6. Do not perform any duties of Contractor.
- F. Associated Services: Cooperate with agencies performing required tests, inspections, and similar quality-control services, and provide reasonable auxiliary services as requested. Notify agency sufficiently in advance of operations to permit assignment of personnel but not less than 24 hours in advance of operations requiring tests and inspections. Provide the following:
 - 1. Access to the Work.
 - 2. Incidental labor and facilities necessary to facilitate tests and inspections.
 - 3. Adequate quantities of representative samples of materials that require testing and inspecting. Assist agency in obtaining samples.
 - 4. Facilities for storage and field curing of test samples.
 - 5. Delivery of samples to testing agencies.
 - 6. Preliminary design mix proposed for use for material mixes that require control by testing agency.
 - 7. Security and protection for samples and for testing and inspecting equipment at Project site.
- G. Coordination: Coordinate sequence of activities to accommodate required quality-assurance and -control services with a minimum of delay and to avoid necessity of removing and replacing construction to accommodate testing and inspecting.
 - 1. Schedule times for tests, inspections, obtaining samples, and similar activities.

1.8 SPECIAL TESTS AND INSPECTIONS

- A. Special Tests and Inspections: Owner will engage a qualified testing agency and / or special inspector to conduct special tests and inspections required by authorities having jurisdiction as the responsibility of Owner, and as follows:
 - 1. Verifying that manufacturer maintains detailed fabrication and quality-control procedures and reviewing the completeness and adequacy of those procedures to perform the Work.

2. Notifying Architect and Contractor promptly of irregularities and deficiencies observed in the Work during performance of its services.
3. Submitting a certified written report of each test, inspection, and similar quality-control service to Architect with copy to Contractor and to authorities having jurisdiction.
4. Submitting a final report of special tests and inspections at Substantial Completion, which includes a list of unresolved deficiencies.
5. Interpreting tests and inspections and stating in each report whether tested and inspected work complies with or deviates from the Contract Documents.
6. Retesting and reinspecting corrected work.

PART 2 - PRODUCTS (Not Used)

PART 3 - EXECUTION

3.1 TEST AND INSPECTION LOG

- A. Prepare a record of tests and inspections. Include the following:
 1. Date test or inspection was conducted.
 2. Description of the Work tested or inspected.
 3. Date test or inspection results were transmitted to Architect.
 4. Identification of testing agency or special inspector conducting test or inspection.
- B. Maintain log at Project site. Post changes and modifications as they occur. Provide access to test and inspection log for Architect's reference during normal working hours.

3.2 REPAIR AND PROTECTION

- A. General: On completion of testing, inspecting, sample taking, and similar services, repair damaged construction and restore substrates and finishes.
 1. Provide materials and comply with installation requirements specified in other Specification Sections. Restore patched areas and extend restoration into adjoining areas with durable seams that are as invisible as possible.
 2. Comply with the Contract Document requirements for Division 01 Section "Cutting and Patching."
- B. Protect construction exposed by or for quality-control service activities.
- C. Repair and protection are Contractor's responsibility, regardless of the assignment of responsibility for quality-control services.

END OF SECTION 014000

THIS PAGE INTENTIONALLY BLANK

SECTION 014200 - REFERENCES

PART 1 - GENERAL

1.1 RELATED DOCUMENTS

- A. Drawings and general provisions of the Contract, including General and Supplementary Conditions and other Division 01 Specification Sections, apply to this Section.

1.2 DEFINITIONS

- A. General: Basic Contract definitions are included in the Conditions of the Contract.
- B. "Approved": When used to convey Architect's action on Contractor's submittals, applications, and requests, "approved" is limited to Architect's duties and responsibilities as stated in the Conditions of the Contract.
- C. "Directed": A command or instruction by Architect. Other terms including "requested," "authorized," "selected," "required," and "permitted" have the same meaning as "directed."
- D. "Indicated": Requirements expressed by graphic representations or in written form on Drawings, in Specifications, and in other Contract Documents. Other terms including "shown," "noted," "scheduled," and "specified" have the same meaning as "indicated."
- E. "Regulations": Laws, ordinances, statutes, and lawful orders issued by authorities having jurisdiction, and rules, conventions, and agreements within the construction industry that control performance of the Work.
- F. "Furnish": Supply and deliver to Project site, ready for unloading, unpacking, assembly, installation, and similar operations.
- G. "Install": Operations at Project site including unloading, temporarily storing, unpacking, assembling, erecting, placing, anchoring, applying, working to dimension, finishing, curing, protecting, cleaning, and similar operations.
- H. "Provide": Furnish and install, complete and ready for the intended use.
- I. "Project Site": Space available for performing construction activities. The extent of Project site is shown on Drawings and may or may not be identical with the description of the land on which Project is to be built.

1.3 INDUSTRY STANDARDS

- A. Applicability of Standards: Unless the Contract Documents include more stringent requirements, applicable construction industry standards have the same force and effect as if bound or copied directly into the Contract Documents to the extent referenced. Such standards are made a part of the Contract Documents by reference.

- B. Publication Dates: Comply with standards in effect as of date of the Contract Documents unless otherwise indicated.
- C. Copies of Standards: Each entity engaged in construction on Project should be familiar with industry standards applicable to its construction activity. Copies of applicable standards are not bound with the Contract Documents.
 - 1. Where copies of standards are needed to perform a required construction activity, obtain copies directly from publication source.

1.4 ABBREVIATIONS AND ACRONYMS

- A. Industry Organizations: Where abbreviations and acronyms are used in Specifications or other Contract Documents, they shall mean the recognized name of the entities indicated in Thomson Gale's "Encyclopedia of Associations" or in Columbia Books' "National Trade & Professional Associations of the U.S."

PART 2 - PRODUCTS (Not Used)

PART 3 - EXECUTION (Not Used)

END OF SECTION 014200

SECTION 015000 – CONSTRUCTION FACILITIES AND TEMPORARY CONTROLS

PART 1 - GENERAL

1.1 RELATED DOCUMENTS

- A. Drawings and general provisions of the Contract, including General and Supplementary Conditions and other Division 1 Specification Sections, apply to this Section.
- B. Related Sections include the following:
 - 1. Divisions 2 through 33 for specific requirements for products in those Sections.

1.2 DEFINITIONS

- A. Permanent Enclosure: As determined by Architect, permanent or temporary roofing is complete, insulated, and weather-tight; exterior walls are insulated and weather-tight; and all openings are closed with permanent construction or substantial temporary closures.

1.3 USE CHARGES

- A. General: Cost or use charges for temporary facilities shall be included in the Contract Sum unless otherwise indicated. Allow other entities to use temporary services and facilities without cost, including, but not limited to, the following:
 - 1. Owner's construction forces.
 - 2. Occupants of Project.
 - 3. Architect.
 - 4. Testing agencies.
 - 5. Personnel of authorities having jurisdiction.
- B. Sewer Service: Owner will pay sewer-service use charges for sewer usage by all entities for construction operations.
- C. Water Service: Owner will pay water-service use charges for water usage by all entities for construction operations. This does not include water conveyed by water truck for sitework use.
- D. Electric Power Service: Owner will pay electric power-service use charges for electricity usage by all entities for construction operations.

1.4 QUALITY ASSURANCE

- A. Standards: Comply with ANSI A10.6, NECA's "Temporary Electrical Facilities," and NFPA 241.
 - 1. Trade Jurisdictions: Assigned responsibilities for installation and operation of

temporary utilities are not intended to interfere with trade regulations and union jurisdictions.

2. Electrical Service: Comply with NECA, NEMA, and UL standards and regulations for temporary electric service. If required, install service to comply with NFPA 70.
- B. Tests and Inspections: Arrange for authorities having jurisdiction to test and inspect each temporary utility before use. Obtain required certifications and permits.

1.5 PROJECT CONDITIONS

- A. Temporary Utilities: At earliest feasible time, when acceptable to Owner, change over from use of temporary service to use of permanent service.
1. Temporary Use of Permanent Facilities: Installer of each permanent service shall assume responsibility for operation, maintenance, and protection of each permanent service during its use as a construction facility before Owner's acceptance, regardless of previously assigned responsibilities.
- B. Conditions of Use: The following conditions apply to use of temporary services and facilities by all parties engaged in the Work:
1. Keep temporary services and facilities clean and neat.
 2. Relocate temporary services and facilities as required by progress of the Work.

PART 2 – PRODUCTS

2.1 MATERIALS

- A. General: Provide new materials. Undamaged, previously used materials in serviceable condition may be used if approved by Architect. Provide materials suitable for use intended.

2.2 EQUIPMENT

- A. General: Provide equipment suitable for use intended.
- B. Field Offices and Sheds: Will not be allowed on site without approval of the Construction Manager. Locate as per the direction of the Construction Manager.
- C. Fire Extinguishers: Hand carried, portable, UL rated. Provide class and extinguishing agent as indicated or a combination of extinguishers of NFPA-recommended classes for exposures.
1. Comply with NFPA 10 and NFPA 241 for classification, extinguishing agent, and size required by location and class of fire exposure.

- D. Drinking Water Fixtures: Bottled water drinking water units including paper cup supply.
 - 1. Where power is accessible, provide electric water coolers to maintain dispensed water temperature at 45 to 55 degrees F.
- E. Heating Equipment: Use of permanent heating systems within the building shall not be used during the course of construction. Freeze protection throughout the building, and heat required to maintain temperatures required for specific types of work, shall be provided by means of vented, self-contained, liquid-propane-gas or fuel-oil heaters with individual space thermostatic controls.
 - 1. Use of gasoline-burning space heaters, open-flame heaters, or salamander-type heating units is prohibited.
 - 2. Heating Units: Listed and labeled, by a testing agency acceptable to authorities having jurisdiction, and marked for intended use for type of fuel being consumed.
- F. Electrical Outlets: Properly configured, NEMA-polarized outlets to prevent insertion of 110-to 120-V plugs into higher voltage outlets; equipped with ground-fault circuit interrupters, reset button, and pilot light.
- G. Power Distribution System Circuits: Where permitted and overhead and exposed for surveillance, wiring circuits, not exceeding 125-V ac, 20-A rating, and lighting circuits may be nonmetallic sheathed cable.

PART 3 – EXECUTION

3.1 INSTALLATION, GENERAL

- A. Locate facilities where they will serve Project adequately and result in minimum interference with performance of Work. Relocate and modify facilities as required.
- B. Provide each facility ready for use when needed to avoid delay. Maintain and modify as required. Do not remove until facilities are no longer needed or are replaced by authorized use of completed permanent facilities.

3.2 TEMPORARY UTILITIES

- A. General: Engage appropriate local utility company to install temporary service or connect to existing service. Where utility company provides only part of the service, provide the remainder with matching, compatible materials and equipment. Comply with utility company recommendations.
 - 1. Provide adequate capacity at each stage of construction.
- B. Water Service:
 - 1. Owner will pay cost of temporary water. Exercise measures to conserve water. Utilize Owner's existing water system, extend and supplement with temporary devices as needed to maintain specified conditions for construction operations.

2. Contractor shall pay to extend branch piping with outlets, if required, located so water is available by hoses with threaded connections for individual use. Provide temporary pipe insulation to prevent freezing.
 3. Provide rubber hoses as necessary to serve Project site.
- C. Sanitary Facilities: The Construction Manager shall provide and maintain temporary toilets and wash facilities.
- D. Heating and Ventilation: The Construction Manager shall provide temporary heating units and ventilating fans as required for curing or drying of completed installation or for protecting installed construction from adverse effects of low temperatures or high humidity, or to prevent the accumulation of dust, fumes, vapors or gases. Select equipment from that specified that will not have a harmful effect on completed installations or elements being installed.
1. Maintain a minimum temperature of 50 degrees F in permanently enclosed portions of building for normal construction activities, and 65 degrees F for finishing activities and areas where finished Work has been installed.
- E. Electrical Power Service: Provide weatherproof, grounded electric power service and distribution system of sufficient size, capacity, and power characteristics during construction period. Include meters, transformers, overload-protected disconnecting means, automatic ground-fault interrupters, and main distribution switchgear.
1. The Electrical Contractor will provide a temporary power source at the project site and a distribution system to the new building area and the staging area from the temporary power source.
 2. The voltage provided at point of distribution will be 120/208, single phase, except as noted in electrical drawings for provision of temporary power when modifying electrical.
 3. All Contractors shall provide their own UL approved extension cords and any adapters required.
 4. Provide waterproof connectors to connect separate lengths of electrical power cords if single lengths will not reach areas where construction activities are in progress. Do not exceed safe length-voltage ratio.
 5. All Contractors shall provide supplementary electrical power to handle welding machines or furnish gasoline operated welders, at their option.
 6. Contractor shall provide labor to relocate, as required, distribution boxes to each desired location. Each re-location is subject to the Construction Manager's approval.
- F. Lighting:
1. The Construction Manager shall provide temporary light strings for general lighting purposes. Lamps will be furnished, installed and maintained by the Electrical Contractor. The Electrical Contractor shall provide labor for installing and moving light strings to desired locations. Each new location is subject to the Construction Manager's approval. The above CM-provided lighting is for

minimal general illumination only. Each contractor shall provide all required work lighting in sufficient quantity and quality to adequately execute the work.

2. Specifically, the Contractors responsible for the execution of the work which will affect the final appearance of surfaces (i.e., CMU, gypsum, drywall, lath and plaster, painting, etc.) shall provide rolling lighting assemblies sufficient to deliver 50 foot candles of illumination on these surfaces while work is actually in progress.
3. Install and operate temporary lighting that fulfills security and protection requirements without operating entire system.
4. Maintain lighting in corridors and hallways during normal construction time frames to ensure safe routes of passage.

G. Telephone Service: The Construction Manager shall provide Contractor's telephone service at the Construction Manager's field office for local telephone calls. Long distance calls will be permitted provided the charges are reversed or are previously approved and paid for by the party originating the call. Other telephone services are the responsibility of the Contractor.

H. Facsimile: Provide for facsimile service and a dedicated telephone line to field office at time of project mobilization.

3.3 SUPPORT FACILITIES

A. General: Comply with the following:

1. Locate field offices, storage sheds, sanitary facilities, and other temporary construction and support facilities for easy access.
2. Maintain support facilities until near Substantial Completion. Remove before Substantial Completion. Personnel remaining after Substantial Completion will be permitted to use permanent facilities, under conditions acceptable to Owner.

B. Dewatering Facilities and Drains: Comply with requirements in applicable Division 2 Sections for temporary drainage and dewatering facilities and operations not directly associated with construction activities included in individual Sections. Where feasible, use same facilities. Maintain project site, excavations, and construction free of water.

1. Grade site to drain. Provide, operate, and maintain pumping equipment.
2. Protect site from puddling or running water. Provide water barriers as required to protect site from soil erosion.

C. Erosion and Sediment Control:

1. Contractor shall plan and execute construction by methods to control surface drainage from cuts and fills, from borrow and waste disposal areas. Prevent erosion and sedimentation.
2. Minimize surface area of bare soil exposed at one time.
3. Provide temporary measures including berms, dikes, drains, and other devices to prevent water flow.

4. Construct fill and waste areas by selective placement to avoid erosive surface silts or clays.
 5. Periodically inspect earthwork to detect evidence of erosion and sedimentation; promptly apply corrective measures.
- D. Storm Water Control: Provide earthen embankments and similar barriers in and around excavations and subgrade construction, sufficient to prevent flooding by runoff of storm water from heavy rains.
- E. Project Identification and Temporary Signs: Prepare Project identification and other signs in sizes indicated. Install signs to inform public and persons seeking entrance to Project. Do not permit installation of unauthorized signs.
1. Engage an experienced sign painter to apply graphics for Project identification signs. Comply with details indicated at the end of this Section.
 2. Prepare temporary signs to provide directional information to construction personnel and visitors.
 3. Construct signs of exterior type Grade B-B high density concrete form overlay plywood in sizes and thickness indicated. Support on posts or framing of preservative-treated wood or steel.
 4. Paint sign panel and applied graphics with exterior grade alkyd gloss enamel over exterior primer.
 5. All signage requires approval of Construction Manager prior to installation.
- F. Waste Disposal Facilities: Provide waste-collection containers in sizes adequate to handle waste from construction operations.
- G. Field Surveying and Layout: The Owner, through the Construction Manager will provide overall initial layout of building structures and overall control information including building corner points, floor elevation, parking lot edges, asphalt grade breaks, and location of major utility locations as shown on the drawings. Detailed surveying required by each Contractor for his own work will be the responsibility of that Contractor. Any staking destroyed by Contractor's activities must be promptly re-staked and shall be the responsibility of that Contractor to replace.

3.4 SECURITY AND PROTECTION

- A. Environmental Protection: Provide protection, operate temporary facilities, and conduct construction in ways and by methods that comply with environmental regulations and that minimize possible air, waterway, and subsoil contamination, pollution or other undesirable effects. Avoid using tools and equipment that produce harmful noise. Restrict use of noisemaking tools and equipment to hours that will minimize complaints from persons or firms near Project site.
- B. Security Enclosure and Lockup: Contractor shall be responsible for and provide security program during the construction period.
1. Protect Work and existing premises from theft, vandalism, and unauthorized entry.
 2. Initiate program at project mobilization.

3. Maintain program throughout construction period until Owner occupancy.
- C. Security Restrictions:
1. Do not work on Saturdays, Sundays, or Holidays without Construction Manager approval.
- D. Barricades, Warning Signs, and Lights: Contractor shall provide barriers to prevent unauthorized entry to construction areas and protect existing facilities and adjacent properties from damage from construction operations. Comply with standards and code requirements for erecting structurally adequate barricades. Paint with appropriate colors, graphics, and warning signs to inform personnel and public of possible hazard. Where appropriate and needed, provide lighting, including flashing warning lights.
1. Contractor shall provide 6' high fence around their individual construction staging site, equip with vehicular and pedestrian gates with locks.
 2. Contractor shall be responsible for protection of their stored materials on site.
 3. Contractor shall provide protection for non-owned vehicular traffic, stored materials, site, and structures from damage.
 4. Contractors are responsible for fall protection for their portions of work, including but not limited to safety lines, railings and warning signs.
- E. Temporary Enclosures: Provide temporary enclosures for protection of construction, in progress and completed, from exposure, foul weather, other construction operations, and similar activities. Provide temporary weather tight enclosure for building exterior.
1. The Owner through the Construction Manager will provide and direct the installation of temporary enclosures where needed for containment of heat. Coordinate enclosure with ventilating and material drying or curing requirements to avoid dangerous conditions and effects.
 2. Vertical openings: Close openings of 25 sq. ft. or less with plywood or similar materials.
 3. Horizontal openings: Close openings in floor or roof decks and horizontal surfaces with load-bearing, wood framed construction.
 4. Install tarpaulins securely using fire-retardant-treated wood framing and other materials.
- F. Temporary Fire Protection: Until fire-protection needs are supplied by permanent facilities, install and maintain temporary fire-protection facilities of types needed to protect against reasonably predictable and controllable fire losses. Comply with NFPA 241.
1. Provide fire extinguishers, installed on walls on mounting brackets, visible and accessible from space being served, with sign mounted above.
 - a. Field Offices: Class-A stored-pressure water-type extinguishers.
 - b. Other Locations: Class ABC dry-chemical extinguishers or a combination of extinguishers of NFPA-recommended classes for exposures.
 - c. Locate fire extinguishers where conventional and effective for their intended purpose.

2. Store combustible materials in containers in fire-safe locations.
3. Maintain unobstructed access to fire extinguishers, fire hydrants, temporary fire-protection facilities and other access routes for firefighting. Prohibit smoking on school property.
4. Supervise welding operations, combustion-type temporary heating units, and similar sources of fire ignition.
5. Permanent Fire Protection: At earliest feasible date in each area of Project, complete installation of permanent fire-protection facility, including connected services, and place into operation and use. Instruct key personnel on use of facilities.
6. Develop and supervise an overall fire-prevention and first-aid fire-protection program for personnel at Project site. Review needs with local fire department and establish procedures to be followed. Instruct personnel in methods and procedures. Post warnings and information.

G. Provide protection for plant life designated to remain. Replace damaged plant life.

3.5 DUST CONTROL

- A. Contractor shall execute Work by methods to minimize raising dust from construction operations.
- B. Provide positive means to prevent air-borne dust from dispersing into atmosphere

3.6 PARKING

- A. Construction personnel parking is to be provided by Owner and shall be located as per the Construction Manager.
- B. Do not allow heavy vehicles or construction equipment in finished parking areas.
- C. Permanent Pavements And Parking Facilities:
 1. Prior to Substantial Completion, bases for permanent roads and parking areas may be used for construction traffic.
 2. Avoid traffic loading beyond paving design capacity. Tracked vehicles not allowed.
- E. Maintenance: Maintain traffic and parking areas in sound condition free of excavated material, construction equipment, products, mud, snow, and ice.
- F. Mud From Site Vehicles: Contractor to provide means of removing mud from vehicle wheels before entering streets.

4.7 TRAFFIC REGULATIONS, SIGNS AND SIGNALS

- A. Contractor shall be responsible for traffic regulation; and when required, provide a written traffic plan.

1. Post Mounted and Wall Mounted Traffic Control and Informational Signs: As approved by authority having jurisdiction.
2. Automatic Traffic Control Signals: As approved by local jurisdictions.
3. Traffic Cones and Drums, Flares and Lights: As approved by authority having jurisdiction.
4. Flag Persons: Provide trained and equipped flag persons to regulate traffic when construction operations or traffic encroach on public traffic lanes.
5. Flares and Lights: Use flares and lights during hours of low visibility to delineate traffic lanes and to guide traffic.
6. Haul Routes: Consult with authority having jurisdiction, establish public thoroughfares to be used for haul routes and site access.
7. Provide signs at approaches to site and on site, at crossroads, detours, parking areas, and elsewhere as needed to direct construction and affected public traffic.
8. Provide, operate, and maintain [automatic] traffic control signals to direct and maintain orderly flow of traffic in areas under Contractor's control, and areas affected by Contractor's operations.
9. Relocate as Work progresses, to maintain effective traffic control.
10. Remove equipment and devices when no longer required at Substantial Completion.
11. Repair damage caused by installation.
12. Remove post settings.

4.8 ACCESS AND CONSTRUCTION AIDES

- A. Roof Top Access: Access to all areas will be the responsibility of the Contractor requiring access. All vertical and horizontal access shall be maintained in a safe state, meeting OSHA standards for by Contractors requiring access.
- B. Temporary Vertical Transportation: Contractor shall provide temporary ladders, ramps, material hoists, scaffolding, cranes and other devices required for the Work, including guys, bracing and other required devices.

3.9 PROGRESS CLEANING AND WASTE REMOVAL

- A. Contractors shall be responsible for own waste removal/disposal and maintaining areas free of waste materials, debris and rubbish. Demolition materials are to be removed and disposed of in a legal manner by any contractor performing demolition work.
 1. Open free-fall chutes are not permitted. Terminate closed chutes into appropriate containers with lids.
- B. Contractors shall broom clean work areas daily.
- C. If Contractor fails to clean up his work area in a timely and satisfactory manner after 24-hours notice, the Construction Manager will cause the clean up to be done by others at the expense of the Contractor.

3.10 PROTECTION OF INSTALLED WORK BY CONTRACTOR

- A. Contractors to protect their installed Work and provide special protection where specified in individual Specification Sections. This includes covering work with visqueen or heat blankets to protect from freezing or adverse weather conditions. Owner will pay costs for tenting and heating of those elements.
- B. Provide temporary and removable protection for installed Products. Control activity in immediate work area to prevent damage.
- C. Protect finished floors, stairs, walls, ceilings and soffits, finished openings and other surfaces from traffic, dirt, wear, damage, or movement of heavy objects, by protecting with durable sheet materials.
- D. Prohibit traffic or storage upon waterproofed or roofed surfaces. If traffic or activity is necessary, obtain recommendations for protection from waterproofing or roofing material manufacturer.
- E. Prohibit traffic across landscaped areas.

3.11 OPERATION, TERMINATION, AND REMOVAL

- A. Maintenance: Maintain facilities in good operating condition until removal. Protect from damage caused by freezing temperatures and similar elements.
 - 1. Maintain operation of temporary enclosures, heating, cooling, humidity control, ventilation, and similar facilities on a 24-hour basis where required to achieve indicated results and to avoid possibility of damage.
 - 2. Prevent water-filled piping from freezing. Maintain markers for underground lines. Protect from damage during excavation operations.
- B. Temporary Facility Changeover: Except for using permanent fire protection as soon as available, do not change over from using temporary security and protection facilities to permanent facilities until Substantial Completion.
- C. Termination and Removal: Remove each temporary facility when need for its service has ended, when it has been replaced by authorized use of a permanent facility, or no later than Substantial Completion. Complete or, if necessary, restore permanent construction that may have been delayed because of interference with temporary facility. Repair damaged Work, clean exposed surfaces, and replace construction that cannot be satisfactorily repaired.
 - 1. Materials and facilities that constitute temporary facilities are the property of Contractor.
 - 2. Remove underground installations to minimum depth of 2 feet. Grade site as indicated on Drawings.
 - 3. Where area is intended for landscape development, remove soil and aggregate fill that do not comply with requirements for fill or subsoil. Remove materials contaminated with road oil, asphalt and other petrochemical compounds, and

other substances that might impair growth of plant materials or lawns. Repair or replace street paving, curbs, and sidewalks at temporary entrances, as required by authorities having jurisdiction.

4. Clean and repair damage caused by installation or use of temporary work.
5. Restore existing and permanent facilities used during construction to original condition. Restore permanent facilities used during construction to specified condition.
6. At Substantial Completion, clean and renovate permanent facilities used during construction period. Comply with final cleaning requirements in Division 1 Section "Closeout Procedures."

3.12 MISCELLANEOUS

- A. Pets are not allowed on job-site.
- B. Firearms are not allowed on job-site.
- C. Loud or distracting music is not allowed on job-site. Contractors to comply with local noise ordinances to protect workers and public.
- D. Smoking is unlawful on School Property.
- E. Per Idaho Code 18-8329, the contractor will prohibit any persons in their employ who are registered or are required to register under the sex offender registration act from participation on this project if such participation would require them to enter upon school property.

END OF SECTION 015000

THIS PAGE INTENTIONALLY BLANK

SECTION 016000 - PRODUCT REQUIREMENTS

PART 1 - GENERAL

1.1 RELATED DOCUMENTS

- A. Drawings and general provisions of the Contract, including General and Supplementary Conditions and other Division 01 Specification Sections, apply to this Section.

1.2 SUMMARY

- A. This Section includes administrative and procedural requirements for selection of products for use in Project; product delivery, storage, and handling; manufacturers' standard warranties on products; special warranties; and product substitutions.
- B. Contractor shall incorporate into the Work only those products specified, indicated as basis-of-design products, those products approved in Addenda prior to bidding, or as approved after award of Contract under conditions set forth in Paragraphs 1.4 and 2.2 below.

1.3 DEFINITIONS

- A. Products: Items purchased for incorporating into the Work, whether purchased for Project or taken from previously purchased stock. The term "product" includes the terms "material," "equipment," "system," and terms of similar intent.
 - 1. Named Products: Items identified by manufacturer's product name, including make or model number or other designation shown or listed in manufacturer's published product literature, that is current as of date of the Contract Documents.
 - 2. New Products: Items that have not previously been incorporated into another project or facility, except that products consisting of recycled-content materials are allowed, unless explicitly stated otherwise. Products salvaged or recycled from other projects are not considered new products.
 - 3. Comparable Product: Product that is demonstrated and approved through submittal process, or where indicated as a product substitution, to have the indicated qualities related to type, function, dimension, in-service performance, physical properties, appearance, and other characteristics that equal or exceed those of specified product.
- B. Substitutions: Changes in products, materials, equipment, and methods of construction from those required by the Contract Documents and proposed by Contractor.
- C. Basis-of-Design Product Specification: Where a specific manufacturer's product is named and accompanied by the words "basis of design," including make or model number or other designation, to establish the significant qualities related to type, function, dimension, in-service performance, physical properties, appearance, and other characteristics.

1.4 SUBMITTALS

- A. Substitution Requests: Submit three copies of each request for consideration. Identify product or fabrication or installation method to be replaced. Include Specification Section number and title and Drawing numbers and titles.
1. Documentation: Show compliance with requirements for substitutions and the following, as applicable:
 - a. Statement indicating why specified material or product cannot be provided.
 - b. Coordination information, including a list of changes or modifications needed to other parts of the Work and to construction performed by Owner and separate contractors, that will be necessary to accommodate proposed substitution.
 - c. Detailed comparison of significant qualities of proposed substitution with those of the Work specified. Significant qualities may include attributes such as performance, weight, size, durability, visual effect, and specific features and requirements indicated.
 - d. Product Data, including drawings and descriptions of products and fabrication and installation procedures.
 - e. Samples, where applicable or requested.
 - f. List of similar installations for completed projects with project names and addresses and names and addresses of architects and owners.
 - g. Material test reports from a qualified testing agency indicating and interpreting test results for compliance with requirements indicated.
 - h. Research/evaluation reports evidencing compliance with building code in effect for Project, from a model code organization acceptable to authorities having jurisdiction.
 - i. Detailed comparison of Contractor's Construction Schedule using proposed substitution with products specified for the Work, including effect on the overall Contract Time. If specified product or method of construction cannot be provided within the Contract Time, include letter from manufacturer, on manufacturer's letterhead, stating lack of availability or delays in delivery.
 - j. Cost information, including a proposal of change, if any, in the Contract Sum.
 - k. Contractor's certification that proposed substitution complies with requirements in the Contract Documents and is appropriate for applications indicated.
 - l. Contractor's waiver of rights to additional payment or time that may subsequently become necessary because of failure of proposed substitution to produce indicated results.
 2. Architect's Action: If necessary, Architect will request additional information or documentation for evaluation within 10 days of receipt of a request for substitution. Architect will notify Contractor of acceptance or rejection of proposed substitution within 15 days of receipt of request, or 10 days of receipt of additional information or documentation, whichever is later.
 - a. Form of Acceptance: Change Order.
 - b. Use product specified if Architect cannot make a decision on use of a proposed substitution within time allocated.

1.5 QUALITY ASSURANCE

- A. Compatibility of Options: If Contractor is given option of selecting between two or more products for use on Project, product selected shall be compatible with products previously selected, even if previously selected products were also options.
 - 1. Contractor is responsible for providing products and construction methods compatible with all other products and construction methods of other contractors.

1.6 PRODUCT DELIVERY, STORAGE, AND HANDLING

- A. Deliver, store, and handle products using means and methods that will prevent damage, deterioration, and loss, including theft. Comply with manufacturer's written instructions.
- B. Delivery and Handling:
 - 1. Schedule delivery to minimize long-term storage at Project site and to prevent overcrowding of construction spaces.
 - 2. Coordinate delivery with installation time to ensure minimum holding time for items that are flammable, hazardous, easily damaged, or sensitive to deterioration, theft, and other losses.
 - 3. Deliver products to Project site in an undamaged condition in manufacturer's original sealed container or other packaging system, complete with labels and instructions for handling, storing, unpacking, protecting, and installing.
 - 4. Inspect products on delivery to ensure compliance with the Contract Documents and to ensure that products are undamaged and properly protected.
- C. Storage:
 - 1. Store products to allow for inspection and measurement of quantity or counting of units.
 - 2. Store materials in a manner that will not endanger Project structure.
 - 3. Store products that are subject to damage by the elements, under cover in a weathertight enclosure above ground, with ventilation adequate to prevent condensation.
 - 4. Store cementitious products and materials on elevated platforms.
 - 5. Store foam plastic from exposure to sunlight, except to extent necessary for period of installation and concealment.
 - 6. Comply with product manufacturer's written instructions for temperature, humidity, ventilation, and weather-protection requirements for storage.
 - 7. Protect stored products from damage and liquids from freezing.
 - 8. Provide a secure location and enclosure at Project site for storage of materials and equipment by Owner's construction forces. Coordinate location with Owner.

1.7 PRODUCT WARRANTIES

- A. Warranties specified in other Sections shall be in addition to, and run concurrent with, other warranties required by the Contract Documents. Manufacturer's disclaimers and limitations on product warranties do not relieve Contractor of obligations under requirements of the Contract Documents.

1. Manufacturer's Warranty: Preprinted written warranty published by individual manufacturer for a particular product and specifically endorsed by manufacturer to Owner.
 2. Special Warranty: Written warranty required by or incorporated into the Contract Documents, either to extend time limit provided by manufacturer's warranty or to provide more rights for Owner.
- B. Special Warranties: Prepare a written document that contains appropriate terms and identification, ready for execution. Submit a draft for approval before final execution.
1. Manufacturer's Standard Form: Modified to include Project-specific information and properly executed.
 2. Specified Form: When specified forms are included with the Specifications, prepare a written document using appropriate form properly executed.
 3. Refer to Divisions 02 through 49 Sections for specific content requirements and particular requirements for submitting special warranties.
- C. Submittal Time: Comply with requirements in Division 01 Section "Closeout Procedures."

PART 2 - PRODUCTS

2.1 PRODUCT SELECTION PROCEDURES

- A. General Product Requirements: Provide products that comply with the Contract Documents, that are undamaged and, unless otherwise indicated, that are new at time of installation.
1. Provide products complete with accessories, trim, finish, fasteners, and other items needed for a complete installation and indicated use and effect.
 2. Standard Products: If available, and unless custom products or nonstandard options are specified, provide standard products of types that have been produced and used successfully in similar situations on other projects.
 3. Owner reserves the right to limit selection to products with warranties not in conflict with requirements of the Contract Documents.
 4. Where products are accompanied by the term "as selected," Architect will make selection.
 5. Where products are accompanied by the term "match sample," sample to be matched is Architect's.
 6. Descriptive, performance, and reference standard requirements in the Specifications establish "salient characteristics" of products.
 7. Or Equal: Where products are specified by name and accompanied by the term "or equal" or "or approved equal" or "or approved," comply with provisions in Part 2 "Comparable Products" Article to obtain approval for use of an unnamed product.
- B. Product Selection Procedures:
1. Product: Where Specifications name a single product and manufacturer, provide the named product that complies with requirements.
 2. Manufacturer/Source: Where Specifications name a single manufacturer or source, provide a product by the named manufacturer or source that complies with requirements.

3. Products: Where Specifications include a list of names of both products and manufacturers, provide one of the products listed that complies with requirements.
4. Manufacturers: Where Specifications include a list of manufacturers' names, provide a product by one of the manufacturers listed that complies with requirements.
5. Available Products: Where Specifications include a list of names of both products and manufacturers, provide one of the products listed, or an unnamed product, that complies with requirements. Comply with provisions in Part 2 "Comparable Products" Article for consideration of an unnamed product.
6. Available Manufacturers: Where Specifications include a list of manufacturers, provide a product by one of the manufacturers listed, or an unnamed manufacturer, that complies with requirements. Comply with provisions in Part 2 "Comparable Products" Article for consideration of an unnamed product.
7. Product Options: Where Specifications indicate that sizes, profiles, and dimensional requirements on Drawings are based on a specific product or system, provide the specified product or system. Comply with provisions in Part 2 "Product Substitutions" Article for consideration of an unnamed product or system.
8. Basis-of-Design Product: Where Specifications name a product, provide the specified product. Drawings and Specifications indicate sizes, profiles, dimensions, and other characteristics that are based on the product named. Products by other manufacturers are subject to approval prior to bidding.
9. Visual Matching Specification: Where Specifications require matching an established Sample, select a product that complies with requirements and matches Architect's sample. Architect's decision will be final on whether a proposed product matches.
 - a. If no product available within specified category matches and complies with other specified requirements, comply with provisions in Part 2 "Product Substitutions" Article for proposal of product.
10. Visual Selection Specification: Where Specifications include the phrase "as selected from manufacturer's colors, patterns, textures" or a similar phrase, select a product that complies with other specified requirements.
 - a. Standard Range: Where Specifications include the phrase "standard range of colors, patterns, textures" or similar phrase, Architect will select color, pattern, density, or texture from manufacturer's product line that does not include premium items.
 - b. Full Range: Where Specifications include the phrase "full range of colors, patterns, textures" or similar phrase, Architect will select color, pattern, density, or texture from manufacturer's product line that includes both standard and premium items.

2.2 PRODUCT SUBSTITUTIONS

- A. Timing: Following award of Contract, Architect will consider requests for substitution for products specified, or approved by addendum under any or all of the following conditions:
 1. The specified product cannot be provided within the Contract Time. The request will not be considered if the product cannot be provided as a result of the Contractor's failure to pursue the Work promptly or coordinate activities properly.

2. The specified product cannot receive necessary approvals by governing authorities, and the requested substitution can be approved.
3. A substantial advantage is offered the Owner, in terms of cost, time, energy conservation or other considerations of merit, after deducting offsetting responsibilities the Owner may be required to bear. Additional responsibilities for the Owner may include additional compensation to the Architect for redesign and evaluation services, increased cost of other construction by the Owner or separate Contractors, and similar considerations.
4. The specified product cannot be provided in a manner that is compatible with other materials, or cannot be properly coordinated, warranted, or insured, and where the Contractor certifies that the substitution will overcome the deficiency.

B. By making a request for substitution, contractor warrants that:

1. Requested substitution does not require extensive revisions to the Contract Documents.
2. Requested substitution is consistent with the Contract Documents and will produce indicated results.
3. Substitution request is fully documented and properly submitted.
4. Requested substitution will not adversely affect Contractor's Construction Schedule.
5. Requested substitution has received necessary approvals of authorities having jurisdiction.
6. Requested substitution is compatible with other portions of the Work.
7. Requested substitution has been coordinated with other portions of the Work.
8. Requested substitution provides specified warranty.
9. If requested substitution involves more than one contractor, requested substitution has been coordinated with other portions of the Work, is uniform and consistent, is compatible with other products, and is acceptable to all contractors involved.

PART 3 - EXECUTION (Not Used)

END OF SECTION 016000

SECTION 017300 - EXECUTION

PART 1 - GENERAL

1.1 SUMMARY

- A. Section includes general administrative and procedural requirements governing execution of the Work, including, but not limited to, the following:
 - 1. Construction layout.
 - 2. Field engineering and surveying.
 - 3. Installation of the Work.
 - 4. Cutting and patching.
 - 5. Coordination of Owner's portion of the Work.
 - 6. Coordination of Owner-installed products.
 - 7. Progress cleaning.
 - 8. Starting and adjusting.
 - 9. Protection of installed construction.
 - 10. Correction of the Work.

- B. Related Requirements:
 - 1. Section 011000 "Summary" for coordination of Owner-furnished products and limits on use of Project site.
 - 2. Section 024119 "Selective Demolition" for demolition and removal of selected portions of the building.

1.2 DEFINITIONS

- A. Cutting: Removal of in-place construction necessary to permit installation or performance of subsequent work.

- B. Patching: Fitting and repair work required to restore construction to original conditions after installation of subsequent work.

1.3 PREINSTALLATION MEETINGS

- A. Cutting and Patching Conference: Conduct conference at Project site.
 - 1. Prior to commencing work requiring cutting and patching, review extent of cutting and patching anticipated and examine procedures for ensuring satisfactory result from cutting and patching work. Inform Architect and Construction Manager of scheduled meeting. Require representatives of each entity directly concerned with cutting and patching to attend, including the following:
 - a. Contractor's superintendent.
 - b. Trade supervisor responsible for cutting operations.

- c. Trade supervisor(s) responsible for patching of each type of substrate.
 - d. Mechanical, electrical, and utilities subcontractors' supervisors, to the extent each trade is affected by cutting and patching operations.
 2. Review areas of potential interference and conflict. Coordinate procedures and resolve potential conflicts before proceeding.
- B. Layout Conference: Conduct conference at Project site.
 1. Prior to establishing layout of new and existing perimeter and structural column grid(s), review building location requirements. Review benchmark, control point, and layout and dimension requirements. Inform Architect and Construction Manager of scheduled meeting. Require representatives of each entity directly concerned with Project layout to attend, including the following:
 - a. Contractor's superintendent.
 - b. Professional surveyor and Contractor's personnel responsible for performing Project surveying and layout.
 2. Review meanings and intent of dimensions, notes, terms, graphic symbols, and other layout information indicated on the Drawings.
 3. Review requirements for including layouts on Shop Drawings and other submittals.
 4. Review areas of potential interference and conflict. Coordinate procedures and resolve potential conflicts before proceeding.

1.4 QUALITY ASSURANCE

- A. Land Surveyor Qualifications: A professional land surveyor who is legally qualified to practice in jurisdiction where Project is located and who is experienced in providing land-surveying services of the kind indicated.
- B. Cutting and Patching: Comply with requirements for and limitations on cutting and patching of construction elements.
 1. Structural Elements: When cutting and patching structural elements, or when encountering the need for cutting and patching of elements whose structural function is not known, notify Architect of locations and details of cutting and await directions from Architect before proceeding. Shore, brace, and support structural elements during cutting and patching. Do not cut and patch structural elements in a manner that could change their load-carrying capacity or increase deflection.
 2. Operational Elements: Do not cut and patch operating elements and related components in a manner that results in reducing their capacity to perform as intended or that results in increased maintenance or decreased operational life or safety.
 3. Other Construction Elements: Do not cut and patch other construction elements or components in a manner that could change their load-carrying capacity, that results in reducing their capacity to perform as intended, or that results in increased maintenance or decreased operational life or safety.

4. Visual Elements: Do not cut and patch construction in a manner that results in visual evidence of cutting and patching. Do not cut and patch exposed construction in a manner that would, in Architect's opinion, reduce the building's aesthetic qualities. Remove and replace construction that has been cut and patched in a visually unsatisfactory manner.
- C. Manufacturer's Installation Instructions: Obtain and maintain on-site manufacturer's written recommendations and instructions for installation of specified products and equipment.

PART 2 - PRODUCTS

2.1 MATERIALS

- A. In-Place Materials: Use materials for patching identical to in-place materials. For exposed surfaces, use materials that visually match in-place adjacent surfaces to the fullest extent possible.
1. If identical materials are unavailable or cannot be used, use materials that, when installed, will provide a match acceptable to Architect for the visual and functional performance of in-place materials. Use materials that are not considered hazardous.
- B. Cleaning Agents: Use cleaning materials and agents recommended by manufacturer or fabricator of the surface to be cleaned. Do not use cleaning agents that are potentially hazardous to health or property or that might damage finished surfaces.

PART 3 - EXECUTION

3.1 EXAMINATION

- A. Existing Conditions: The existence and location of underground and other utilities and construction indicated as existing are not guaranteed. Before beginning sitework, investigate and verify the existence and location of underground utilities, mechanical and electrical systems, and other construction affecting the Work.
1. Before construction, verify the location and invert elevation at points of connection of sanitary sewer, storm sewer, gas service piping, and water-service piping; underground electrical services; and other utilities.
 2. Furnish location data for work related to Project that must be performed by public utilities serving Project site.
- B. Examination and Acceptance of Conditions: Before proceeding with each component of the Work, examine substrates, areas, and conditions, with Installer or Applicator present where indicated, for compliance with requirements for installation tolerances and other conditions affecting performance. Record observations. Record photographs shall be taken of all building and site areas to document pre-demolition and construction conditions.
1. Examine roughing-in for mechanical and electrical systems to verify actual locations of connections before equipment and fixture installation.

2. Examine walls, floors, and roofs for suitable conditions where products and systems are to be installed.
 3. Verify compatibility with and suitability of substrates, including compatibility with existing finishes or primers.
- C. Proceed with installation only after unsatisfactory conditions have been corrected. Proceeding with the Work indicates acceptance of surfaces and conditions.

3.2 PREPARATION

- A. Existing Utility Information: Furnish information to local utility that is necessary to adjust, move, or relocate existing utility structures, utility poles, lines, services, or other utility appurtenances located in or affected by construction. Coordinate with authorities having jurisdiction.
- B. Field Measurements: Take field measurements as required to fit the Work properly. Recheck measurements before installing each product. Where portions of the Work are indicated to fit to other construction, verify dimensions of other construction by field measurements before fabrication. Coordinate fabrication schedule with construction progress to avoid delaying the Work.
- C. Space Requirements: Verify space requirements and dimensions of items shown diagrammatically on Drawings.
- D. Review of Contract Documents and Field Conditions: Immediately on discovery of the need for clarification of the Contract Documents, submit a request for information to Architect through Construction Manager in accordance with requirements in Section 013100 "Project Management and Coordination."

3.3 CONSTRUCTION LAYOUT

- A. Verification: Before proceeding to lay out the Work, verify layout information shown on Drawings, in relation to the property survey and existing benchmarks and existing conditions. If discrepancies are discovered, notify Architect and Construction Manager promptly.
- B. Engage a land surveyor experienced in laying out the Work, using the following accepted surveying practices:
 1. Establish benchmarks and control points to set lines and levels at each story of construction and elsewhere as needed to locate each element of Project.
 2. Establish limits on use of Project site.
 3. Establish dimensions within tolerances indicated. Do not scale Drawings to obtain required dimensions.
 4. Inform installers of lines and levels to which they must comply.
 5. Check the location, level and plumb, of every major element as the Work progresses.
 6. Notify Architect and Construction Manager when deviations from required lines and levels exceed allowable tolerances.
 7. Close site surveys with an error of closure equal to or less than the standard established by authorities having jurisdiction.

- C. Site Improvements: Locate and lay out site improvements, including pavements, grading, fill and topsoil placement, utility slopes, and rim and invert elevations.
- D. Building Lines and Levels: Locate and lay out control lines and levels for structures, building foundations, column grids, and floor levels, including those required for mechanical and electrical work. Transfer survey markings and elevations for use with control lines and levels. Level foundations and piers from two or more locations.
- E. Record Log: Maintain a log of layout control work. Record deviations from required lines and levels. Include beginning and ending dates and times of surveys, weather conditions, name and duty of each survey party member, and types of instruments and tapes used. Make the log available for reference by Architect and Construction Manager.

3.4 FIELD ENGINEERING

- A. Reference Points: Locate existing permanent benchmarks, control points, and similar reference points before beginning the Work. Preserve and protect permanent benchmarks and control points during construction operations.
 - 1. Do not change or relocate existing benchmarks or control points without prior written approval of Architect or Construction Manager. Report lost or destroyed permanent benchmarks or control points promptly. Report the need to relocate permanent benchmarks or control points to Architect and Construction Manager before proceeding.
 - 2. Replace lost or destroyed permanent benchmarks and control points promptly. Base replacements on the original survey control points.
- B. Benchmarks: Establish and maintain a minimum of two permanent benchmarks on Project site, referenced to data established by survey control points. Comply with authorities having jurisdiction for type and size of benchmark.
 - 1. Record benchmark locations, with horizontal and vertical data, on Project Record Documents.
 - 2. Where the actual location or elevation of layout points cannot be marked, provide temporary reference points sufficient to locate the Work.
 - 3. Remove temporary reference points when no longer needed. Restore marked construction to its original condition.

3.5 INSTALLATION

- A. Locate the Work and components of the Work accurately, in correct alignment and elevation, as indicated.
 - 1. Make vertical work plumb, and make horizontal work level.
 - 2. Where space is limited, install components to maximize space available for maintenance and ease of removal for replacement.
 - 3. Conceal pipes, ducts, and wiring in finished areas unless otherwise indicated.
 - 4. Maintain minimum headroom clearance of 96 inches in occupied spaces and 90 inches in unoccupied spaces, unless otherwise indicated on Drawings.

- B. Comply with manufacturer's written instructions and recommendations for installing products in applications indicated.
- C. Install products at the time and under conditions that will ensure satisfactory results as judged by Architect. Maintain conditions required for product performance until Substantial Completion.
- D. Conduct construction operations, so no part of the Work is subjected to damaging operations or loading in excess of that expected during normal conditions of occupancy of type expected for Project.
- E. Sequence the Work and allow adequate clearances to accommodate movement of construction items on-site and placement in permanent locations.
- F. Tools and Equipment: Select tools or equipment that minimize production of excessive noise levels.
- G. Templates: Obtain and distribute to the parties involved templates for Work specified to be factory prepared and field installed. Check Shop Drawings of other portions of the Work to confirm that adequate provisions are made for locating and installing products to comply with indicated requirements.
- H. Attachment: Provide blocking and attachment plates and anchors and fasteners of adequate size and number to securely anchor each component in place, accurately located and aligned with other portions of the Work. Where size and type of attachments are not indicated, verify size and type required for load conditions with manufacturer.
 - 1. Mounting Heights: Where mounting heights are not indicated, mount components at heights directed by Architect.
 - 2. Allow for building movement, including thermal expansion and contraction.
 - 3. Coordinate installation of anchorages. Furnish setting drawings, templates, and directions for installing anchorages, including sleeves, concrete inserts, anchor bolts, and items with integral anchors, that are to be embedded in concrete or masonry. Deliver such items to Project site in time for installation.
- I. Joints: Make joints of uniform width. Where joint locations in exposed Work are not indicated, arrange joints for the best visual effect, as judged by Architect. Fit exposed connections together to form hairline joints.

3.6 CUTTING AND PATCHING

- A. General: Employ skilled workers to perform cutting and patching. Proceed with cutting and patching at the earliest feasible time, and complete without delay.
 - 1. Cut in-place construction to provide for installation of other components or performance of other construction, and subsequently patch as required to restore surfaces to their original condition.

- B. Existing Warranties: Remove, replace, patch, and repair materials and surfaces cut or damaged during installation or cutting and patching operations, by methods and with materials so as not to void existing warranties.
- C. Temporary Support: Provide temporary support of Work to be cut.
- D. Protection: Protect in-place construction during cutting and patching to prevent damage. Provide protection from adverse weather conditions for portions of Project that might be exposed during cutting and patching operations.
- E. Adjacent Occupied Areas: Where interference with use of adjoining areas or interruption of free passage to adjoining areas is unavoidable, coordinate cutting and patching in accordance with requirements in Section 011000 "Summary."
- F. Existing Utility Services and Mechanical/Electrical Systems: Where existing services/systems are required to be removed, relocated, or abandoned, bypass such services/systems before cutting to minimize interruption to occupied areas.
- G. Cutting: Cut in-place construction by sawing, drilling, breaking, chipping, grinding, and similar operations, including excavation, using methods least likely to damage elements retained or adjoining construction. If possible, review proposed procedures with original Installer; comply with original Installer's written recommendations.
 - 1. In general, use hand or small power tools designed for sawing and grinding, not hammering and chopping. Cut holes and slots neatly to minimum size required, and with minimum disturbance of adjacent surfaces. Temporarily cover openings when not in use.
 - 2. Finished Surfaces: Cut or drill from the exposed or finished side into concealed surfaces.
 - 3. Concrete and Masonry: Cut using a cutting machine, such as an abrasive saw or a diamond-core drill.
 - 4. Excavating and Backfilling: Comply with requirements in applicable Sections where required by cutting and patching operations.
 - 5. Mechanical and Electrical Services: Cut off pipe or conduit in walls or partitions to be removed. Cap, valve, or plug and seal remaining portion of pipe or conduit to prevent entrance of moisture or other foreign matter after cutting.
 - 6. Proceed with patching after construction operations requiring cutting are complete.
- H. Patching: Patch construction by filling, repairing, refinishing, closing up, and similar operations following performance of other Work. Patch with durable seams that are as invisible as practicable, as judged by Architect. Provide materials and comply with installation requirements specified in other Sections, where applicable.
 - 1. Inspection: Where feasible, test and inspect patched areas after completion to demonstrate physical integrity of installation.
 - 2. Exposed Finishes: Restore exposed finishes of patched areas and extend finish restoration into retained adjoining construction in a manner that will eliminate evidence of patching and refinishing.
 - a. Clean piping, conduit, and similar features before applying paint or other finishing materials.
 - b. Restore damaged pipe covering to its original condition.

3. Floors and Walls: Where walls or partitions that are removed extend one finished area into another, patch and repair floor and wall surfaces in the new space. Provide an even surface of uniform finish, color, texture, and appearance. Remove in-place floor and wall coverings and replace with new materials, if necessary, to achieve uniform color and appearance.
 - a. Where patching occurs in a painted surface, prepare substrate and apply primer and intermediate paint coats appropriate for substrate over the patch, and apply final paint coat over entire unbroken surface containing the patch, corner to corner of wall and edge to edge of ceiling. Provide additional coats until patch blends with adjacent surfaces.
 4. Ceilings: Patch, repair, or rehang in-place ceilings as necessary to provide an even-plane surface of uniform appearance.
 5. Exterior Building Enclosure: Patch components in a manner that restores enclosure to a weathertight condition and ensures thermal and moisture integrity of building enclosure.
- I. Cleaning: Clean areas and spaces where cutting and patching are performed. Remove paint, mortar, oils, putty, and similar materials from adjacent finished surfaces.

3.7 COORDINATION OF OWNER'S PORTION OF THE WORK

- A. Site Access: Provide access to Project site for Owner's construction personnel and Owner's separate contractors.
1. Provide temporary facilities required for Owner-furnished, Contractor-installed and Owner-furnished, Owner-installed products.
 2. Refer to Section 011000 "Summary" for other requirements for Owner-furnished, Contractor-installed and Owner-furnished, Owner-installed products.
- B. Coordination: Coordinate construction and operations of the Work with work performed by Owner's construction personnel and Owner's separate contractors.
1. Construction Schedule: Inform Owner of Contractor's preferred construction schedule for Owner's portion of the Work. Adjust construction schedule based on a mutually agreeable timetable. Notify Owner if changes to schedule are required due to differences in actual construction progress.
 2. Preinstallation Conferences: Include Owner's construction personnel and Owner's separate contractors at preinstallation conferences covering portions of the Work that are to receive Owner's work. Attend preinstallation conferences conducted by Owner's construction personnel if portions of the Work depend on Owner's construction.

3.8 PROGRESS CLEANING

- A. Clean Project site and work areas daily, including common areas. Enforce requirements strictly. Dispose of materials lawfully.
1. Comply with requirements in NFPA 241 for removal of combustible waste materials and debris.

2. Do not hold waste materials more than seven days during normal weather or three days if the temperature is expected to rise above 80 deg F (27 deg C).
 3. Containerize hazardous and unsanitary waste materials separately from other waste. Mark containers appropriately and dispose of legally, according to regulations.
 - a. Use containers intended for holding waste materials of type to be stored.
 4. Coordinate progress cleaning for joint-use areas where Contractor and other contractors are working concurrently.
- B. Site: Maintain Project site free of waste materials and debris.
- C. Work Areas: Clean areas where Work is in progress to the level of cleanliness necessary for proper execution of the Work.
1. Remove liquid spills promptly.
 2. Where dust would impair proper execution of the Work, broom-clean or vacuum the entire work area, as appropriate.
- D. Installed Work: Keep installed work clean. Clean installed surfaces according to written instructions of manufacturer or fabricator of product installed, using only cleaning materials specifically recommended. If specific cleaning materials are not recommended, use cleaning materials that are not hazardous to health or property and that will not damage exposed surfaces.
- E. Concealed Spaces: Remove debris from concealed spaces before enclosing the space.
- F. Exposed Surfaces: Clean exposed surfaces and protect as necessary to ensure freedom from damage and deterioration at time of Substantial Completion.
- G. Waste Disposal: Do not bury or burn waste materials on-site. Do not wash waste materials down sewers or into waterways.
- H. During handling and installation, clean and protect construction in progress and adjoining materials already in place. Apply protective covering where required to ensure protection from damage or deterioration at Substantial Completion.
- I. Clean and provide maintenance on completed construction as frequently as necessary through the remainder of the construction period. Adjust and lubricate operable components to ensure operability without damaging effects.
- J. Limiting Exposures: Supervise construction operations to ensure that no part of the construction, completed or in progress, is subject to harmful, dangerous, damaging, or otherwise deleterious exposure during the construction period.
- 3.9 STARTING AND ADJUSTING
- A. Coordinate startup and adjusting of equipment and operating components with requirements in Section 019113 "General Commissioning Requirements."
 - B. Start equipment and operating components to confirm proper operation. Remove malfunctioning units, replace with new units, and retest.

- C. Adjust equipment for proper operation. Adjust operating components for proper operation without binding.
- D. Test each piece of equipment to verify proper operation. Test and adjust controls and safeties. Replace damaged and malfunctioning controls and equipment.
- E. Manufacturer's Field Service: Comply with qualification requirements in Section 014000 "Quality Requirements."

3.10 PROTECTION OF INSTALLED CONSTRUCTION

- A. Provide final protection and maintain conditions that ensure installed Work is without damage or deterioration at time of Substantial Completion.
- B. Protection of Existing Items: Provide protection and ensure that existing items to remain undisturbed by construction are maintained in condition that existed at commencement of the Work.
- C. Comply with manufacturer's written instructions for temperature and relative humidity.

3.11 CORRECTION OF THE WORK

- A. Repair or remove and replace damaged, defective, or nonconforming Work. Restore damaged substrates and finishes.
 - 1. Repairing includes replacing defective parts, refinishing damaged surfaces, touching up with matching materials, and properly adjusting operating equipment.
- B. Repair Work previously completed and subsequently damaged during construction period. Repair to like-new condition.
- C. Restore permanent facilities used during construction to their specified condition.
- D. Remove and replace damaged surfaces that are exposed to view if surfaces cannot be repaired without visible evidence of repair.
- E. Repair components that do not operate properly. Remove and replace operating components that cannot be repaired.
- F. Remove and replace chipped, scratched, and broken glass or reflective surfaces.

END OF SECTION 017300

SECTION 017329 - CUTTING AND PATCHING

PART 1 - GENERAL

1.1 RELATED DOCUMENTS

- A. Drawings and general provisions of the Contract, including General and Supplementary Conditions and other Division 01 Specification Sections, apply to this Section.

1.2 SUMMARY

- A. This Section includes procedural requirements for cutting and patching.

1.3 DEFINITIONS

- A. Cutting: Removal of in-place construction necessary to permit installation or performance of other Work.
- B. Patching: Fitting and repair work required to restore surfaces to original conditions after installation of other Work.

1.4 SUBMITTALS

- A. Cutting and Patching Proposal: Submit a proposal describing procedures at least 10 days before the time cutting and patching will be performed, requesting approval to proceed. Include the following information:
 - 1. Extent: Describe cutting and patching, show how they will be performed, and indicate why they cannot be avoided.
 - 2. Changes to In-Place Construction: Describe anticipated results. Include changes to structural elements and operating components as well as changes in building's appearance and other significant visual elements.
 - 3. Products: List products to be used and firms or entities that will perform the Work.
 - 4. Dates: Indicate when cutting and patching will be performed.
 - 5. Utility Services and Mechanical/Electrical Systems: List services/systems that cutting and patching procedures will disturb or affect. List services/systems that will be relocated and those that will be temporarily out of service. Indicate how long services/systems will be disrupted.
 - 6. Structural Elements: Where cutting and patching involve adding reinforcement to structural elements, submit details and engineering calculations showing integration of reinforcement with original structure.
 - 7. Architect's Approval: Obtain approval of cutting and patching proposal before cutting and patching. Approval does not waive right to later require removal and replacement of unsatisfactory work.

1.5 QUALITY ASSURANCE

- A. Structural Elements: Do not cut and patch structural elements in a manner that could change their load-carrying capacity or load-deflection ratio.
- B. Operational Elements: Do not cut and patch operating elements and related components in a manner that results in reducing their capacity to perform as intended or that results in increased maintenance or decreased operational life or safety. Operating elements include the following:
 - 1. Primary operational systems and equipment.
 - 2. Air or smoke barriers.
 - 3. Fire-suppression systems.
 - 4. Mechanical systems piping and ducts.
 - 5. Control systems.
 - 6. Communication systems.
 - 7. Conveying systems.
 - 8. Electrical wiring systems.
 - 9. Operating systems of special construction in Division 13 Sections.
- C. Miscellaneous Elements: Do not cut and patch miscellaneous elements or related components in a manner that could change their load-carrying capacity, that results in reducing their capacity to perform as intended, or that results in increased maintenance or decreased operational life or safety. Miscellaneous elements include the following:
 - 1. Water, moisture, or vapor barriers.
 - 2. Membranes and flashings.
 - 3. Exterior curtain-wall construction.
 - 4. Equipment supports.
 - 5. Piping, ductwork, vessels, and equipment.
 - 6. Noise- and vibration-control elements and systems.
- D. Visual Requirements: Do not cut and patch construction in a manner that results in visual evidence of cutting and patching. Do not cut and patch construction exposed on the exterior or in occupied spaces in a manner that would, in Architect's opinion, reduce the building's aesthetic qualities. Remove and replace construction that has been cut and patched in a visually unsatisfactory manner.
- E. Cutting and Patching Conference: Before proceeding, meet at Project site with parties involved in cutting and patching, including mechanical and electrical trades. Review areas of potential interference and conflict. Coordinate procedures and resolve potential conflicts before proceeding.

1.6 WARRANTY

- A. Warranties: Remove, replace, patch, and repair materials and surfaces cut or damaged during cutting and patching operations, by methods and with materials so as not to void warranties.

PART 2 - PRODUCTS

2.1 MATERIALS

- A. General: Comply with requirements specified in other Sections.
- B. In-Place Materials: Use materials identical to in-place materials. For exposed surfaces, use materials that visually match in-place adjacent surfaces to the fullest extent possible.
 - 1. If identical materials are unavailable or cannot be used, use materials that, when installed, will match the visual and functional performance of in-place materials.

PART 3 - EXECUTION

3.1 EXAMINATION

- A. Examine surfaces to be cut and patched and conditions under which cutting and patching are to be performed.
 - 1. Compatibility: Before patching, verify compatibility with and suitability of substrates, including compatibility with in-place finishes or primers.
 - 2. Proceed with installation only after unsafe or unsatisfactory conditions have been corrected.

3.2 PREPARATION

- A. Temporary Support: Provide temporary support of Work to be cut.
- B. Protection: Protect in-place construction during cutting and patching to prevent damage. Provide protection from adverse weather conditions for portions of Project that might be exposed during cutting and patching operations.
- C. Adjoining Areas: Avoid interference with use of adjoining areas or interruption of free passage to adjoining areas.
- D. Existing Utility Services and Mechanical/Electrical Systems: Where existing services/systems are required to be removed, relocated, or abandoned, bypass such services/systems before cutting to minimize interruption to occupied areas.

3.3 PERFORMANCE

- A. General: Employ skilled workers to perform cutting and patching. Proceed with cutting and patching at the earliest feasible time, and complete without delay.
 - 1. Cut in-place construction to provide for installation of other components or performance of other construction, and subsequently patch as required to restore surfaces to their original condition.

- B. Cutting: Cut in-place construction by sawing, drilling, breaking, chipping, grinding, and similar operations, including excavation, using methods least likely to damage elements retained or adjoining construction. If possible, review proposed procedures with original Installer; comply with original Installer's written recommendations.
1. In general, use hand or small power tools designed for sawing and grinding, not hammering and chopping. Cut holes and slots as small as possible, neatly to size required, and with minimum disturbance of adjacent surfaces. Temporarily cover openings when not in use.
 2. Finished Surfaces: Cut or drill from the exposed or finished side into concealed surfaces.
 3. Concrete or Masonry: Cut using a cutting machine, such as an abrasive saw or a diamond-core drill.
 4. Excavating and Backfilling: Comply with requirements in applicable Division 31 Sections where required by cutting and patching operations.
 5. Mechanical and Electrical Services: Cut off pipe or conduit in walls or partitions to be removed. Cap, valve, or plug and seal remaining portion of pipe or conduit to prevent entrance of moisture or other foreign matter after cutting.
 6. Proceed with patching after construction operations requiring cutting are complete.
- C. Patching: Patch construction by filling, repairing, refinishing, closing up, and similar operations following performance of other Work. Patch with durable seams that are as invisible as possible. Provide materials and comply with installation requirements specified in other Sections.
1. Inspection: Where feasible, test and inspect patched areas after completion to demonstrate integrity of installation.
 2. Exposed Finishes: Restore exposed finishes of patched areas and extend finish restoration into retained adjoining construction in a manner that will eliminate evidence of patching and refinishing.
 - a. Clean piping, conduit, and similar features before applying paint or other finishing materials.
 - b. Restore damaged pipe covering to its original condition.
 3. Floors and Walls: Where walls or partitions that are removed extend one finished area into another, patch and repair floor and wall surfaces in the new space. Provide an even surface of uniform finish, color, texture, and appearance. Remove in-place floor and wall coverings and replace with new materials, if necessary, to achieve uniform color and appearance.
 - a. Where patching occurs in a painted surface, apply primer and intermediate paint coats over the patch and apply final paint coat over entire unbroken surface containing the patch. Provide additional coats until patch blends with adjacent surfaces.
 4. Ceilings: Patch, repair, or rehang in-place ceilings as necessary to provide an even-plane surface of uniform appearance.
 5. Exterior Building Enclosure: Patch components in a manner that restores enclosure to a weathertight condition.

6. Roofs: Patch and repair per details in project Drawings, per membrane manufacturer's standard details and instructions, and in the case of unique or undocumented conditions, as directed by Architect. Verify that all patches and repairs are sound and watertight.
- D. Cleaning: Clean areas and spaces where cutting and patching are performed. Completely remove paint, mortar, oils, putty, and similar materials.

END OF SECTION 017329

THIS PAGE INTENTIONALLY BLANK

SECTION 017700 - CLOSEOUT PROCEDURES

PART 1 - GENERAL

1.1 RELATED DOCUMENTS

- A. Drawings and general provisions of the Contract, including General and Supplementary Conditions and other Division 01 Specification Sections, apply to this Section.

1.2 SUMMARY

- A. This Section includes administrative and procedural requirements for contract closeout, including, but not limited to, the following:
 - 1. Substantial Completion procedures.
 - 2. Final Completion procedures.
 - 3. Warranties.
 - 4. Final cleaning.

1.3 SUBSTANTIAL COMPLETION

- A. Preliminary Procedures: Before requesting inspection for determining date of Substantial Completion, complete the following. List items below that are incomplete in request.
 - 1. Prepare a list of items to be completed and corrected (punch list), the value of items on the list, and reasons why the Work is not complete.
 - 2. Advise Owner of pending insurance changeover requirements.
 - 3. Submit specific warranties, workmanship bonds, maintenance service agreements, final certifications, and similar documents.
 - 4. Obtain and submit releases permitting Owner unrestricted use of the Work and access to services and utilities. Include occupancy permits, operating certificates, and similar releases.
 - 5. Prepare and submit Project Record Documents.
 - 6. Deliver tools, spare parts, extra materials, and similar items to location designated by Owner. Label with manufacturer's name and model number where applicable.
 - 7. Make final changeover of permanent locks and deliver keys to Owner. Advise Owner's personnel of changeover in security provisions.
 - 8. Complete startup testing of systems.
 - 9. Submit test/adjust/balance records.
 - 10. Terminate and remove temporary facilities from Project site, along with mockups, construction tools, and similar elements.
 - 11. Advise Owner of changeover in heat and other utilities.
 - 12. Submit preliminary manuals required by Specifications Section 017823 (two copies) for review by Architect.
 - 13. Submit changeover information related to Owner's occupancy, use, operation, and maintenance.

14. Complete final cleaning requirements, including touchup painting.
15. Touch up and otherwise repair and restore marred exposed finishes to eliminate visual defects.

B. Inspection: Submit a written request for inspection for Substantial Completion. On receipt of request, Architect will either proceed with inspection or notify Contractor of unfulfilled requirements. Architect will prepare the Certificate of Substantial Completion after inspection or will notify Contractor of items, either on Contractor's list or additional items identified by Architect, that must be completed or corrected before certificate will be issued.

1. Reinspection: Request reinspection when the Work identified in previous inspections as incomplete is completed or corrected.
2. Results of completed inspection will form the basis of requirements for Final Completion.

1.4 FINAL COMPLETION

A. Preliminary Procedures: Before requesting final inspection for determining date of Final Completion, complete the following:

1. Submit a final Application for Payment according to Division 01 Section "Payment Procedures."
2. Submit copy of Architect's Substantial Completion inspection list of items to be completed or corrected (punch list), endorsed and dated by Architect. The certified copy of the list shall state that each item has been completed or otherwise resolved for acceptance.
3. Submit evidence of final, continuing insurance coverage complying with insurance requirements.
4. Submit final manuals required by Specifications Section 017823, corrected in accordance with the Architect's review of the preliminary operations and maintenance manuals submitted at the time of Substantial Completion.
5. Instruct Owner's personnel in operation, adjustment, and maintenance of products, equipment, and systems.

B. Inspection: Submit a written request for final inspection for acceptance. On receipt of request, Architect will either proceed with inspection or notify Contractor of unfulfilled requirements. Architect will prepare a final Certificate for Payment after inspection or will notify Contractor of construction that must be completed or corrected before certificate will be issued.

1. Reinspection: Request reinspection when the Work identified in previous inspections as incomplete is completed or corrected.

1.5 WARRANTIES

A. Submittal Time: Submit written warranties on request of Architect for designated portions of the Work where commencement of warranties other than date of Substantial Completion is indicated.

- B. Partial Occupancy: Submit properly executed warranties within 15 days of completion of designated portions of the Work that are completed and occupied or used by Owner during construction period by separate agreement with Contractor.
- C. Organize warranty documents into an orderly sequence based on the table of contents of the Project Manual.
 - 1. Bind warranties and bonds in heavy-duty, 3-ring, vinyl-covered, loose-leaf binders, thickness as necessary to accommodate contents, and sized to receive 8-1/2-by-11-inch (215-by-280-mm) paper.
 - 2. Provide heavy paper dividers with plastic-covered tabs for each separate warranty. Mark tab to identify the product or installation. Provide a typed description of the product or installation, including the name of the product and the name, address, and telephone number of Installer.
 - 3. Identify each binder on the front and spine with the typed or printed title "WARRANTIES," Project name, and name of Contractor.
- D. Provide additional copies of each warranty to include in operation and maintenance manuals.

PART 2 - PRODUCTS

2.1 MATERIALS

- A. Cleaning Agents: Use cleaning materials and agents recommended by manufacturer or fabricator of the surface to be cleaned. Do not use cleaning agents that are potentially hazardous to health or property or that might damage finished surfaces.

PART 3 - EXECUTION

3.1 FINAL CLEANING

- A. General: Provide final cleaning. Conduct cleaning and waste-removal operations to comply with local laws and ordinances and Federal and local environmental and antipollution regulations.
- B. Cleaning: Employ experienced workers or professional cleaners for final cleaning. Clean each surface or unit to condition expected in an average commercial building cleaning and maintenance program. Comply with manufacturer's written instructions.
 - 1. Complete the following cleaning operations before requesting inspection for certification of Substantial Completion for entire Project or for a portion of Project:
 - a. Clean Project site, yard, and grounds, in areas disturbed by construction activities, including landscape development areas, of rubbish, waste material, litter, and other foreign substances.
 - b. Sweep paved areas broom clean. Remove petrochemical spills, stains, and other foreign deposits.

- c. Rake grounds that are neither planted nor paved to a smooth, even-textured surface.
- d. Remove tools, construction equipment, machinery, and surplus material from Project site.
- e. Remove snow and ice to provide safe access to building.
- f. Clean exposed exterior and interior hard-surfaced finishes to a dirt-free condition, free of stains, films, and similar foreign substances. Avoid disturbing natural weathering of exterior surfaces. Restore reflective surfaces to their original condition.
- g. Remove debris and surface dust from limited access spaces, including roofs, plenums, shafts, trenches, equipment vaults, manholes, attics, and similar spaces.
- h. Sweep concrete floors broom clean in unoccupied spaces.
- i. Vacuum carpet and similar soft surfaces, removing debris and excess nap; shampoo if visible soil or stains remain.
- j. Clean transparent materials, including mirrors and glass in doors and windows. Remove glazing compounds and other noticeable, vision-obscuring materials. Replace chipped or broken glass and other damaged transparent materials. Polish mirrors and glass, taking care not to scratch surfaces.
- k. Remove labels that are not permanent.
- l. Touch up and otherwise repair and restore marred, exposed finishes and surfaces. Replace finishes and surfaces that cannot be satisfactorily repaired or restored or that already show evidence of repair or restoration.
 - 1) Do not paint over "UL" and similar labels, including mechanical and electrical nameplates.
- m. Wipe surfaces of mechanical and electrical equipment, elevator equipment, and similar equipment. Remove excess lubrication, paint and mortar droppings, and other foreign substances.
- n. Replace parts subject to unusual operating conditions.
- o. Clean plumbing fixtures to a sanitary condition, free of stains, including stains resulting from water exposure.
- p. Replace disposable air filters and clean permanent air filters. Clean exposed surfaces of diffusers, registers, and grills.
- q. Clean ducts, blowers, and coils if units were operated without filters during construction.
- r. Clean light fixtures, lamps, globes, and reflectors to function with full efficiency. Replace burned-out bulbs, and those noticeably dimmed by hours of use, and defective and noisy starters in fluorescent and mercury vapor fixtures to comply with requirements for new fixtures.
- s. Leave Project clean and ready for occupancy.

C. Pest Control: Make a final inspection and rid Project of rodents, insects, and other pests.

D. Comply with safety standards for cleaning. Do not burn waste materials. Do not bury debris or excess materials on Owner's property. Do not discharge volatile, harmful, or dangerous materials into drainage systems. Remove waste materials from Project site and dispose of lawfully.

END OF SECTION 017700

SECTION 017823 - OPERATION AND MAINTENANCE DATA

PART 1 - GENERAL

1.1 RELATED DOCUMENTS

- A. Drawings and general provisions of the Contract, including General and Supplementary Conditions and other Division 01 Specification Sections, apply to this Section.

1.2 SUMMARY

- A. This Section includes administrative and procedural requirements for preparing operation and maintenance manuals, including the following:
 - 1. Operation and maintenance documentation directory.
 - 2. Emergency manuals.
 - 3. Operation manuals for systems, subsystems, and equipment.
 - 4. Maintenance manuals for the care and maintenance of products, materials, finishes, systems and equipment.

1.3 DEFINITIONS

- A. System: An organized collection of parts, equipment, or subsystems united by regular interaction.
- B. Subsystem: A portion of a system with characteristics similar to a system.

1.4 SUBMITTALS

- A. Submittal: Submit two copies of each manual in preliminary form as a condition of Substantial Completion. Architect will return copies with required corrections indicated within 15 days after Substantial Completion.
 - 1. Correct or modify each manual to comply with Architect's indicated corrections. Submit 2 copies of each corrected manual prior to Final Acceptance of the Work.
 - 2. Corrected preliminary manuals may be used for final submittal.

1.5 COORDINATION

- A. Where operation and maintenance documentation includes information on installations by more than one factory-authorized service representative, assemble and coordinate information furnished by representatives and prepare manuals.

PART 2 - PRODUCTS

2.1 OPERATION AND MAINTENANCE DOCUMENTATION DIRECTORY

- A. Organization: Include a section in the directory for each of the following:
 - 1. List of documents.
 - 2. List of systems.
 - 3. List of equipment.
 - 4. Table of contents.
- B. List of Systems and Subsystems: List systems alphabetically. Include references to operation and maintenance manuals that contain information about each system.
- C. List of Equipment: List equipment for each system, organized alphabetically by system. For pieces of equipment not part of system, list alphabetically in separate list.
- D. Tables of Contents: Include a table of contents for each emergency, operation, and maintenance manual.
- E. Identification: In the documentation directory and in each operation and maintenance manual, identify each system, subsystem, and piece of equipment with same designation used in the Contract Documents. If no designation exists, assign a designation according to ASHRAE Guideline 4, "Preparation of Operating and Maintenance Documentation for Building Systems."

2.2 MANUALS, GENERAL

- A. Organization: Unless otherwise indicated, organize each manual into a separate section for each system and subsystem, and a separate section for each piece of equipment not part of a system. Each manual shall contain the following materials, in the order listed:
 - 1. Title page.
 - 2. Table of contents.
 - 3. Manual contents.
- B. Title Page: Enclose title page in transparent plastic sleeve. Include the following information:
 - 1. Subject matter included in manual.
 - 2. Name and address of Project.
 - 3. Name and address of Owner.
 - 4. Date of submittal.
 - 5. Name, address, and telephone number of Contractor.
 - 6. Name and address of Architect.
 - 7. Cross-reference to related systems in other operation and maintenance manuals.
- C. Table of Contents: List each product included in manual, identified by product name, indexed to the content of the volume, and cross-referenced to Specification Section number in Project Manual.

1. If operation or maintenance documentation requires more than one volume to accommodate data, include comprehensive table of contents for all volumes in each volume of the set.
- D. Manual Contents: Organize into sets of manageable size. Arrange contents alphabetically by system, subsystem, and equipment. If possible, assemble instructions for subsystems, equipment, and components of one system into a single binder.
1. Binders: Heavy-duty, 3-ring, vinyl-covered, loose-leaf binders, in thickness necessary to accommodate contents, sized to hold 8-1/2-by-11-inch (215-by-280-mm) paper; with clear plastic sleeve on spine to hold label describing contents and with pockets inside covers to hold folded oversize sheets.
 - a. If two or more binders are necessary to accommodate data of a system, organize data in each binder into groupings by subsystem and related components. Cross-reference other binders if necessary to provide essential information for proper operation or maintenance of equipment or system.
 - b. Identify each binder on front and spine, with printed title "OPERATION AND MAINTENANCE MANUAL," Project title or name, and subject matter of contents. Indicate volume number for multiple-volume sets.
 2. Dividers: Heavy-paper dividers with plastic-covered tabs for each section. Mark each tab to indicate contents. Include typed list of products and major components of equipment included in the section on each divider, cross-referenced to Specification Section number and title of Project Manual.
 3. Protective Plastic Sleeves: Transparent plastic sleeves designed to enclose diagnostic software diskettes for computerized electronic equipment.
 4. Supplementary Text: Prepared on 8-1/2-by-11-inch (215-by-280-mm) white bond paper.
 5. Drawings: Attach reinforced, punched binder tabs on drawings and bind with text.
 - a. If oversize drawings are necessary, fold drawings to same size as text pages and use as foldouts.
 - b. If drawings are too large to be used as foldouts, fold and place drawings in labeled envelopes and bind envelopes in rear of manual. At appropriate locations in manual, insert typewritten pages indicating drawing titles, descriptions of contents, and drawing locations.

2.3 OPERATION MANUALS

- A. Content: In addition to requirements in this Section, include operation data required in individual Specification Sections and the following information:
1. System, subsystem, and equipment descriptions.
 2. Performance and design criteria if Contractor is delegated design responsibility.
 3. Operating standards.
 4. Operating procedures.
 5. Operating logs.
 6. Wiring diagrams.
 7. Control diagrams.
 8. Piped system diagrams.

9. Precautions against improper use.
10. License requirements including inspection and renewal dates.

B. Descriptions: Include the following:

1. Product name and model number.
2. Manufacturer's name.
3. Equipment identification with serial number of each component.
4. Equipment function.
5. Operating characteristics.
6. Limiting conditions.
7. Performance curves.
8. Engineering data and tests.
9. Complete nomenclature and number of replacement parts.

C. Operating Procedures: Include the following, as applicable:

1. Startup procedures.
2. Equipment or system break-in procedures.
3. Routine and normal operating instructions.
4. Regulation and control procedures.
5. Instructions on stopping.
6. Normal shutdown instructions.
7. Seasonal and weekend operating instructions.
8. Required sequences for electric or electronic systems.
9. Special operating instructions and procedures.

D. Systems and Equipment Controls: Describe the sequence of operation, and diagram controls as installed.

E. Piped Systems: Diagram piping as installed, and identify color-coding where required for identification.

2.4 PRODUCT MAINTENANCE MANUALS

A. Content: Organize manual into a separate section for each product, material, and finish. Include source information, product information, maintenance procedures, repair materials and sources, and warranties and bonds, as described below.

1. Provide a summary list of all finish materials in manual at the front of the manual.

B. Source Information: List each product included in manual, identified by product name and arranged to match manual's table of contents. For each product, list name, address, and telephone number of Installer or supplier and maintenance service agent, and cross-reference Specification Section number and title in Project Manual.

C. Product Information: Include the following, as applicable:

1. Product name and model number.
2. Manufacturer's name.

3. Color, pattern, and texture.
 4. Material and chemical composition.
 5. Reordering information for specially manufactured products.
- D. Maintenance Procedures: Include manufacturer's written recommendations and the following:
1. Inspection procedures.
 2. Types of cleaning agents to be used and methods of cleaning.
 3. List of cleaning agents and methods of cleaning detrimental to product.
 4. Schedule for routine cleaning and maintenance.
 5. Repair instructions.
- E. Repair Materials and Sources: Include lists of materials and local sources of materials and related services.
- F. Warranties and Bonds: Include copies of warranties and bonds and lists of circumstances and conditions that would affect validity of warranties or bonds.
1. Include procedures to follow and required notifications for warranty claims.

2.5 SYSTEMS AND EQUIPMENT MAINTENANCE MANUALS

- A. Content: For each system, subsystem, and piece of equipment not part of a system, include source information, manufacturers' maintenance documentation, maintenance procedures, maintenance and service schedules, spare parts list and source information, maintenance service contracts, and warranty and bond information, as described below.
- B. Source Information: List each system, subsystem, and piece of equipment included in manual, identified by product name and arranged to match manual's table of contents. For each product, list name, address, and telephone number of Installer or supplier and maintenance service agent, and cross-reference Specification Section number and title in Project Manual.
- C. Manufacturers' Maintenance Documentation: Manufacturers' maintenance documentation including the following information for each component part or piece of equipment:
1. Standard printed maintenance instructions and bulletins.
 2. Drawings, diagrams, and instructions required for maintenance, including disassembly and component removal, replacement, and assembly.
 3. Identification and nomenclature of parts and components.
 4. List of items recommended to be stocked as spare parts.
- D. Maintenance Procedures: Include the following information and items that detail essential maintenance procedures:
1. Test and inspection instructions.
 2. Troubleshooting guide.
 3. Precautions against improper maintenance.
 4. Disassembly; component removal, repair, and replacement; and reassembly instructions.
 5. Aligning, adjusting, and checking instructions.
 6. Demonstration and training videotape, if available.

- E. Maintenance and Service Schedules: Include service and lubrication requirements, list of required lubricants for equipment, and separate schedules for preventive and routine maintenance and service with standard time allotment.
 - 1. Scheduled Maintenance and Service: Tabulate actions for daily, weekly, monthly, quarterly, semiannual, and annual frequencies.
 - 2. Maintenance and Service Record: Include manufacturers' forms for recording maintenance.
- F. Spare Parts List and Source Information: Include lists of replacement and repair parts, with parts identified and cross-referenced to manufacturers' maintenance documentation and local sources of maintenance materials and related services.
- G. Maintenance Service Contracts: Include copies of maintenance agreements with name and telephone number of service agent.
- H. Warranties and Bonds: Include copies of warranties and bonds and lists of circumstances and conditions that would affect validity of warranties or bonds.
 - 1. Include procedures to follow and required notifications for warranty claims.

PART 3 - EXECUTION

3.1 MANUAL PREPARATION

- A. Operation and Maintenance Documentation Directory: Prepare a separate manual that provides an organized reference to emergency, operation, and maintenance manuals.
- B. Product Maintenance Manual: Assemble a complete set of maintenance data indicating care and maintenance of each product, material, and finish incorporated into the Work.
- C. Operation and Maintenance Manuals: Assemble a complete set of operation and maintenance data indicating operation and maintenance of each system, subsystem, and piece of equipment not part of a system.
 - 1. Engage a factory-authorized service representative to assemble and prepare information for each system, subsystem, and piece of equipment not part of a system.
 - 2. Prepare a separate manual for each system and subsystem, in the form of an instructional manual for use by Owner's operating personnel.
- D. Manufacturers' Data: Where manuals contain manufacturers' standard printed data, include only sheets pertinent to product or component installed. Mark each sheet to identify each product or component incorporated into the Work. If data include more than one item in a tabular format, identify each item using appropriate references from the Contract Documents. Identify data applicable to the Work and delete references to information not applicable.
 - 1. Prepare supplementary text if manufacturers' standard printed data are not available and where the information is necessary for proper operation and maintenance of equipment or systems.

- E. Drawings: Prepare drawings supplementing manufacturers' printed data to illustrate the relationship of component parts of equipment and systems and to illustrate control sequence and flow diagrams. Coordinate these drawings with information contained in Record Drawings to ensure correct illustration of completed installation.
 - 1. Do not use original Project Record Documents as part of operation and maintenance manuals.
 - 2. Comply with requirements of newly prepared Record Drawings in Division 01 Section "Project Record Documents."

- F. Comply with Division 01 Section "Closeout Procedures" for schedule for submitting operation and maintenance documentation.

END OF SECTION 017823

THIS PAGE INTENTIONALLY BLANK

SECTION 017839 - PROJECT RECORD DOCUMENTS

PART 1 - GENERAL

1.1 RELATED DOCUMENTS

- A. Drawings and general provisions of the Contract, including General and Supplementary Conditions and other Division 01 Specification Sections, apply to this Section.

1.2 SUMMARY

- A. This Section includes administrative and procedural requirements for Project Record Documents, including the following:
 - 1. Record Drawings.
 - 2. Record Specifications.
 - 3. Record Product Data.

1.3 SUBMITTALS

- A. Record Drawings: Comply with the following:
 - 1. Number of Copies: Submit two set(s) of marked-up Record Prints to Architect.
- B. Record Specifications: Submit two copies of Project's Specifications, including addenda and contract modifications to Architect.
- C. Record Product Data: Submit two copies of each Product Data submittal to Architect.
 - 1. Where Record Product Data is required as part of operation and maintenance manuals, submit marked-up Product Data as an insert in manual in addition to submittal as Record Product Data.

PART 2 - PRODUCTS

2.1 RECORD DRAWINGS

- A. Record Prints: Maintain one set of blue- or black-line white prints of the Contract Drawings and Shop Drawings.
 - 1. Preparation: Mark Record Prints to show the actual installation where installation varies from that shown originally. Require individual or entity who obtained record data, whether individual or entity is Installer, subcontractor, or similar entity, to prepare the marked-up Record Prints.

- a. Give particular attention to information on concealed elements that would be difficult to identify or measure and record later.
 - b. Accurately record information in an understandable drawing technique.
 - c. Record data as soon as possible after obtaining it. Record and check the markup before enclosing concealed installations.
2. Content: Types of items requiring marking include, but are not limited to, the following:
- a. Dimensional changes to Drawings.
 - b. Revisions to details shown on Drawings.
 - c. Depths of foundations below first floor.
 - d. Locations and depths of underground utilities.
 - e. Revisions to routing of piping and conduits.
 - f. Revisions to electrical circuitry.
 - g. Actual equipment locations.
 - h. Duct size and routing.
 - i. Locations of concealed internal utilities.
 - j. Changes made by Change Order or Construction Change Directive.
 - k. Changes made following Architect's written orders.
 - l. Details not on the original Contract Drawings.
 - m. Field records for variable and concealed conditions.
 - n. Record information on the Work that is shown only schematically.
3. Mark the Contract Drawings and Shop Drawings, completely and accurately.
4. Mark record sets with erasable, red-colored pencil. Use other colors to distinguish between changes for different categories of the Work at same location.
5. Mark important additional information that was either shown schematically or omitted from original Drawings.
6. Note Construction Change Directive numbers, alternate numbers, Change Order numbers, and similar identification, where applicable.
- B. Format: Identify and date each Record Drawing; include the designation "PROJECT RECORD DRAWING" in a prominent location.
- 1. Record Prints: Organize Record Prints and newly prepared Record Drawings into manageable sets. Bind each set with durable paper cover sheets. Include identification on cover sheets.
 - 2. Identification: As follows:
 - a. Project name.
 - b. Date.
 - c. Designation "PROJECT RECORD DRAWINGS."
 - d. Name of Architect.
 - e. Name of Contractor.

2.2 RECORD SPECIFICATIONS

- A. Preparation: Mark Specifications to indicate the actual product installation where installation varies from that indicated in Specifications, addenda, and contract modifications.

1. Give particular attention to information on concealed products and installations that cannot be readily identified and recorded later.
2. Mark copy with the proprietary name and model number of products, materials, and equipment furnished, including substitutions and product options selected.
3. Record the name of manufacturer, supplier, Installer, and other information necessary to provide a record of selections made.
4. For each principal product, indicate whether Record Product Data has been submitted in operation and maintenance manuals instead of submitted as Record Product Data.
5. Note related Change Orders, Record Product Data, and Record Drawings where applicable.

2.3 RECORD PRODUCT DATA

- A. Preparation: Mark Product Data to indicate the actual product installation where installation varies substantially from that indicated in Product Data submittal.
1. Give particular attention to information on concealed products and installations that cannot be readily identified and recorded later.
 2. Include significant changes in the product delivered to Project site and changes in manufacturer's written instructions for installation.
 3. Note related Change Orders, Record Specifications, and Record Drawings where applicable.

2.4 MISCELLANEOUS RECORD SUBMITTALS

- A. Assemble miscellaneous records required by other Specification Sections for miscellaneous record keeping and submittal in connection with actual performance of the Work. Bind or file miscellaneous records and identify each, ready for continued use and reference.

PART 3 - EXECUTION

3.1 RECORDING AND MAINTENANCE

- A. Recording: Maintain copies of each submittal during the construction period for Project Record Document purposes. Post changes and modifications to Project Record Documents as they occur; do not wait until the end of Project.
- B. Maintenance of Record Documents and Samples: Store Record Documents and Samples in the field office apart from the Contract Documents used for construction. Do not use Project Record Documents for construction purposes. Maintain Record Documents in good order and in a clean, dry, legible condition, protected from deterioration and loss. Provide access to Project Record Documents for Architect's reference during normal working hours.

END OF SECTION 017839

THIS PAGE INTENTIONALLY BLANK

SECTION 017900 - DEMONSTRATION AND TRAINING

PART 1 - GENERAL

1.1 RELATED DOCUMENTS

- A. Drawings and general provisions of the Contract, including General and Supplementary Conditions and other Division 01 Specification Sections, apply to this Section.

1.2 SUMMARY

- A. Section includes administrative and procedural requirements for instructing Owner's personnel, including the following:
 - 1. Instruction in operation and maintenance of systems, subsystems, and equipment.

1.3 INFORMATIONAL SUBMITTALS

- A. Instruction Program: Submit outline of instructional program for demonstration and training, including a list of training modules and a schedule of proposed dates, times, length of instruction time, and instructors' names for each training module. Include learning objective and outline for each training module.
 - 1. Indicate proposed training modules using manufacturer-produced demonstration and training video recordings for systems, equipment, and products in lieu of video recording of live instructional module.
- B. Attendance Record: For each training module, submit list of participants and length of instruction time.
- C. Evaluations: For each participant and for each training module, submit results and documentation of performance-based test.

1.4 QUALITY ASSURANCE

- A. Facilitator Qualifications: A firm or individual experienced in training or educating maintenance personnel in a training program similar in content and extent to that indicated for this Project, and whose work has resulted in training or education with a record of successful learning performance.

1.5 COORDINATION

- A. Coordinate instruction schedule with Owner's operations. Adjust schedule as required to minimize disrupting Owner's operations and to ensure availability of Owner's personnel.

- B. Coordinate instructors, including providing notification of dates, times, length of instruction time, and course content.
- C. Coordinate content of training modules with content of approved emergency, operation, and maintenance manuals. Do not submit instruction program until operation and maintenance data have been reviewed and approved by Architect.

1.6 INSTRUCTION PROGRAM

- A. Program Structure: Develop an instruction program that includes individual training modules for each system and for equipment not part of a system, as required by individual Specification Sections.
- B. Training Modules: Develop a learning objective and teaching outline for each module. Include a description of specific skills and knowledge that participant is expected to master. For each module, include instruction for the following as applicable to the system, equipment, or component:
 - 1. Basis of System Design, Operational Requirements, and Criteria: Include the following:
 - a. System, subsystem, and equipment descriptions.
 - b. Performance and design criteria if Contractor is delegated design responsibility.
 - c. Operating standards.
 - d. Regulatory requirements.
 - e. Equipment function.
 - f. Operating characteristics.
 - g. Limiting conditions.
 - h. Performance curves.
 - 2. Documentation: Review the following items in detail:
 - a. Emergency manuals.
 - b. Systems and equipment operation manuals.
 - c. Systems and equipment maintenance manuals.
 - d. Product maintenance manuals.
 - e. Project Record Documents.
 - f. Identification systems.
 - g. Warranties and bonds.
 - h. Maintenance service agreements and similar continuing commitments.
 - 3. Emergencies: Include the following, as applicable:
 - a. Instructions on meaning of warnings, trouble indications, and error messages.
 - b. Instructions on stopping.
 - c. Shutdown instructions for each type of emergency.
 - d. Operating instructions for conditions outside of normal operating limits.
 - e. Sequences for electric or electronic systems.
 - f. Special operating instructions and procedures.
 - 4. Operations: Include the following, as applicable:

- a. Startup procedures.
 - b. Equipment or system break-in procedures.
 - c. Routine and normal operating instructions.
 - d. Regulation and control procedures.
 - e. Control sequences.
 - f. Safety procedures.
 - g. Instructions on stopping.
 - h. Normal shutdown instructions.
 - i. Operating procedures for emergencies.
 - j. Operating procedures for system, subsystem, or equipment failure.
 - k. Seasonal and weekend operating instructions.
 - l. Required sequences for electric or electronic systems.
 - m. Special operating instructions and procedures.
5. Adjustments: Include the following:
- a. Alignments.
 - b. Checking adjustments.
 - c. Noise and vibration adjustments.
 - d. Economy and efficiency adjustments.
6. Troubleshooting: Include the following:
- a. Diagnostic instructions.
 - b. Test and inspection procedures.
7. Maintenance: Include the following:
- a. Inspection procedures.
 - b. Types of cleaning agents to be used and methods of cleaning.
 - c. List of cleaning agents and methods of cleaning detrimental to product.
 - d. Procedures for routine cleaning.
 - e. Procedures for preventive maintenance.
 - f. Procedures for routine maintenance.
 - g. Instruction on use of special tools.
8. Repairs: Include the following:
- a. Diagnosis instructions.
 - b. Repair instructions.
 - c. Disassembly; component removal, repair, and replacement; and reassembly instructions.
 - d. Instructions for identifying parts and components.
 - e. Review of spare parts needed for operation and maintenance.

1.7 INSTRUCTION

- A. Facilitator: Engage a qualified facilitator to prepare instruction program and training modules, to coordinate instructors, and to coordinate between Contractor and Owner for number of participants, instruction times, and location.

- B. Scheduling: Provide instruction at mutually agreed-on times. For equipment that requires seasonal operation, provide similar instruction at start of each season.
- C. Training Location and Reference Material: Conduct training on-site in the completed and fully operational facility using the actual equipment in-place. Conduct training using final operation and maintenance data submittals.

PART 2 - PRODUCTS

PART 3 - EXECUTION

END OF SECTION 017900

SECTION 019113 - GENERAL COMMISSIONING REQUIREMENTS

PART 1 - GENERAL

1.1 RELATED DOCUMENTS

- A. Drawings and general provisions of the Contract, including General and Supplementary Conditions and other Division 01 Specification Sections, apply to this Section.

1.2 SUMMARY

- A. Section includes general requirements that apply to implementation of commissioning without regard to specific systems, assemblies, or components.
- B. Related Sections:
 - 1. Section 220800 "Commissioning of Plumbing" for commissioning process activities for Plumbing systems, assemblies, equipment, and components.
 - 2. Section 230800 "Commissioning of HVAC" for commissioning process activities for HVAC&R systems, assemblies, equipment, and components.
 - 3. Section 260800 "Commissioning of Lighting and Controls" for commissioning process activities for lighting and control systems, assemblies, equipment, and components.
- C. Note: Commissioning Authority (CxA) to be a qualified and certified entity selected by the Owner and Construction Manager. The Commissioning entity(s) shall provide labor technical resources as specified herein and as required by the above referenced Specification Sections.

1.3 DEFINITIONS

- A. Commissioning Plan: A document that outlines the organization, schedule, allocation of resources, and documentation requirements of the commissioning process, in accordance with IECC.
- B. CxA: Commissioning Authority. A Commissioning Authority, NEBB or AABC Certified, and either an Independent Contractor or Project Engineer of Record fully qualified and selected by the Owner.
- C. Systems, Subsystems, Equipment, and Components: Where these terms are used together or separately, they shall mean "as-built" systems, subsystems, equipment, and components.

1.4 COMMISSIONING TEAM

- A. Members Appointed by the Construction Manager: Individuals, each having the authority to act on behalf of the entity he or she represents, explicitly organized to implement the commissioning process through coordinated action. The commissioning team shall consist of, but not be limited to, representatives of each Contractor, including the project superintendent, subcontractors, installers, suppliers, and specialists deemed appropriate by the CxA.

- B. Members Appointed by Owner:
 - 1. Representatives of the facility user and operation and maintenance personnel.
 - 2. Architect and engineering design professionals, as needed.

1.5 OWNER'S RESPONSIBILITIES

- A. Assign operation and maintenance personnel and schedule them to participate in commissioning team activities.
- B. Provide design and construction documentation, prepared by Architect and approved by Owner, to the CxA and each Contractor for use in developing the commissioning plan, per IECC current adopted version.

1.6 CONTRACTOR'S RESPONSIBILITIES

- A. Contractor shall assign representatives with expertise and authority to act on its behalf and shall schedule them to participate in and perform commissioning process activities including, but not limited to, the following:
 - 1. Evaluate performance deficiencies identified in test reports and, in collaboration with entity responsible for system and equipment installation, recommend corrective action.
 - 2. Cooperate with the CxA for resolution of issues recorded in the Issues Log.
 - 3. Attend commissioning team meetings held on as necessary.
 - 4. Integrate and coordinate commissioning process activities with construction schedule.
 - 5. Review and accept construction checklists provided by the CxA.
 - 6. Complete electronic construction checklists as Work is completed and provide to the Commissioning Authority on a weekly basis.
 - 7. Review and accept commissioning process test procedures provided by the Commissioning Authority.
 - 8. Complete commissioning process test procedures.

1.7 CxA'S RESPONSIBILITIES

- A. Organize and lead the commissioning team. Follow discipline-specific requirements set out in referenced specification sections and per IECC.
- B. Provide commissioning plan per IECC current adopted version.
- C. Convene commissioning team meetings as necessary.
- D. Provide Project-specific construction checklists and commissioning process test procedures.
- E. Verify the execution of commissioning process activities using random sampling. The sampling rate may vary from 1 to 20 percent. Verification will include, but is not limited to, equipment submittals, construction checklists, training, operating and maintenance data, tests, and test reports to verify compliance with the bid document. When a random sample does not meet the

requirement, the CxA will report the failure in the Issues Log.

- F. Prepare and maintain the Issues Log.
- G. Prepare and maintain completed construction checklist log.
- H. Witness systems, assemblies, equipment, and component startup.
- I. Compile test data, inspection reports, and certificates; include them in the systems manual and commissioning process report. Verify and document that all control sequences for new equipment have been tested and function under full, part and emergency load conditions per IECC.
- J. Provide preliminary commissioning report to Engineer and Owner stating the following, per IECC:
 - 1. Itemization of deficiencies found during TAB that have not been corrected at time of report.
 - 2. Deferred test (if any) that can't be performed at time of report due to climatic conditions.
 - 3. Climatic conditions required for performance of deferred tests.
- K. Final report per IECC

PART 2 - PRODUCTS (Not Used)

PART 3 - EXECUTION (Not Used)

END OF SECTION 019113

THIS PAGE INTENTIONALLY BLANK

SECTION 024119 - SELECTIVE STRUCTURE DEMOLITION

PART 1 - GENERAL

1.1 RELATED DOCUMENTS

- A. Drawings and general provisions of the Contract, including General and Supplementary Conditions and Division 01 Specification Sections, apply to this Section.

1.2 SUMMARY

- A. Section Includes:
 - 1. Demolition and removal of selected portions of existing building and related improvements.

1.3 DEFINITIONS

- A. Remove: Detach items from existing construction and legally dispose of them off-site unless indicated to be removed and salvaged or removed and reinstalled.
- B. Existing to Remain: Existing items of construction that are not to be permanently removed and that are not otherwise indicated to be removed, removed and salvaged, or removed and reinstalled.

1.4 MATERIALS OWNERSHIP

- A. Unless otherwise indicated, demolition waste becomes property of Contractor.
- B. Items indicated to be removed by Owner shall be retained by Owner for subsequent use elsewhere.

1.5 FIELD CONDITIONS

- A. Owner will occupy portions of building immediately adjacent to selective demolition area. Conduct selective demolition so Owner's operations will not be disrupted.
- B. Conditions existing at time of inspection for bidding purpose will be maintained by Owner as far as practical.
- C. Notify Architect of discrepancies between existing conditions and Drawings before proceeding with selective demolition.
- D. Hazardous Materials: Hazardous materials may be encountered in the Work.

1. If suspected hazardous materials are encountered, do not disturb; immediately notify Architect and Owner.
 2. See Specification Sections 011000, 028211, and 028333 and General Conditions.
- E. Storage or sale of removed items or materials on-site is not permitted.
- F. Utility Service: Maintain existing utilities indicated to remain in service and protect them against damage during selective demolition operations.
1. Maintain and protect underground, in-wall, and above ceiling plumbing and electrical during selective demolition operations.

PART 2 - PRODUCTS

2.1 PERFORMANCE REQUIREMENTS

- A. Regulatory Requirements: Comply with governing EPA notification regulations before beginning selective demolition. Comply with hauling and disposal regulations of authorities having jurisdiction.
- B. Standards: Comply with ANSI/ASSE A10.6 and NFPA 241.

PART 3 - EXECUTION

3.1 EXAMINATION

- A. Verify that applicable utilities have been located, and disconnected and capped as applicable, before starting selective demolition operations.
- B. Survey existing conditions and correlate with requirements indicated to determine extent of selective demolition required.
- C. When unanticipated mechanical, electrical, or structural elements that conflict with intended function or design are encountered, investigate and measure the nature and extent of conflict. Promptly submit a written report to Architect.
- D. Survey of Existing Conditions: Record existing conditions by use of preconstruction photographs.

3.2 UTILITY SERVICES AND MECHANICAL/ELECTRICAL SYSTEMS

- A. Existing Services/Systems to Remain: Maintain services/systems indicated to remain and protect them against damage.
1. Comply with requirements for existing services/systems interruptions specified in Division 01 Section "Summary."

- B. Existing Services/Systems to Be Removed, Relocated, or Abandoned: Where applicable, locate, identify, disconnect, and seal or cap off indicated utility services and mechanical/electrical systems serving areas to be selectively demolished.

3.3 PREPARATION

- A. Temporary Shoring: Provide and maintain shoring, bracing, and structural supports as required to preserve stability and prevent movement, settlement, or collapse of construction and finishes to remain, and to prevent unexpected or uncontrolled movement or collapse of construction being demolished.
 - 1. Strengthen or add new supports when required during progress of selective demolition.
- B. Weather Protection: Provide and maintain suitable temporary weather protection at roof, wall, and building openings subject to partial or selective demolition. Weather protection shall include tarps, sheeting, plywood and / or temporary construction as applicable.
- C. Building Egress: Consult with local fire jurisdiction regarding required building egress during selective demolition and subsequent construction activities.

3.4 SELECTIVE DEMOLITION, GENERAL

- A. General: Demolish and remove existing construction only to the extent required by new construction and as indicated. Use methods required to complete the Work within limitations of governing regulations and as follows:
 - 1. Proceed with selective demolition systematically, from higher to lower level. Complete selective demolition operations above each floor or tier before disturbing supporting members on the next lower level.
 - 2. Neatly cut openings and holes plumb, square, and true to dimensions required. Use cutting methods least likely to damage construction to remain or adjoining construction. Use hand tools or small power tools designed for sawing or grinding, not hammering and chopping, to minimize disturbance of adjacent surfaces. Temporarily cover openings to remain.
 - 3. Cut or drill from the exposed or finished side into concealed surfaces to avoid marring existing finished surfaces.
 - 4. Do not use cutting torches until work area is cleared of flammable materials. At concealed spaces, such as duct and pipe interiors, verify condition and contents of hidden space before starting flame-cutting operations. Maintain portable fire-suppression devices during flame-cutting operations.
 - 5. Maintain adequate ventilation when using cutting torches.
 - 6. Remove decayed, vermin-infested, or otherwise dangerous or unsuitable materials and promptly dispose of off-site.
 - 7. Remove structural framing members and lower to ground by method suitable to avoid free fall and to prevent ground impact or dust generation.
 - 8. Locate selective demolition equipment and remove debris and materials so as not to impose excessive loads on supporting walls, floors, or framing.
 - 9. Dispose of demolished items and materials promptly.

- B. Existing Items to Remain: Protect construction indicated to remain and building spaces outside limits of construction against damage and soiling during selective demolition.

3.5 SELECTIVE DEMOLITION PROCEDURES FOR SPECIFIC MATERIALS

- A. Roofs and Roofing: Remove roofing and related roof framing. Do not remove roofing until new construction and / or replacement roofing can commence or provide temporary water-tight covering.
- B. Doors and Frames: Remove doors and hardware from door frames, then where required, detach entire frame from wall framing and remove. Retain door hardware and turn over to Owner as intact sets.
- C. Finishes, Cabinetry, and Specialty Items: Remove finishes carefully where substrate is to remain. Remove cabinetry after disconnecting any plumbing and electrical devices. Remove specialty items and transfer any such items to be retained by Owner to approved storage location.
- D. Walls and Miscellaneous Wood Framing: Remove finish materials and sheathing, then remove studs, plates, and miscellaneous framing members.
- E. Steel Members: Unbolt and / or torch cut steel members in strict compliance with project Drawings and Specifications as applicable.
- F. Concrete Foundations and Slab-on-Grade: Saw-cut exterior concrete flatwork, building floor slabs, and foundation elements as applicable, then break up and remove.
- G. Mechanical, Electrical, and Plumbing Items: Disconnect electrical power, low voltage connections, gas, and water as applicable. Remove equipment, component, or fixture, with related connections, to the extent specified and required.

3.6 DISPOSAL OF DEMOLISHED MATERIALS

- A. General: Except for items or materials indicated to be reused, salvaged, reinstalled, or otherwise indicated to remain Owner's property, remove demolished materials from Project site and legally dispose.
 - 1. Do not allow demolished materials to accumulate on-site.
 - 2. Remove and transport debris in a manner that will prevent spillage on adjacent surfaces and areas.

3.7 CLEANING

- A. Clean adjacent structures and improvements of dust, dirt, and debris caused by selective demolition operations. Return adjacent areas to condition existing before selective demolition operations began.

END OF SECTION 024119

SECTION 028211 – ASBESTOS ABATEMENT

1.0 GENERAL

- A. This Specification Document shall apply to and be used in conjunction with the Jefferson Elementary School Pre-Renovation Survey - Asbestos and Lead-Based Paint Testing Report prepared by Atlas Technical Consultants, dated January 19, 2023, and contained in Appendix B of this Project Manual.

1.1 SUMMARY

- A. The following procedures apply to the project manual and drawings for this project and shall be a part of the contract documents of the project.
- B. The Contractor's responsibilities shall include providing competent supervision, labor, materials, equipment, transportation, permits, personnel monitoring, etc., required to remove and dispose of asbestos containing materials (ACM). The Contractor shall adhere to all provisions in this document and shall comply with the latest federal, state and local agency requirements governing worker safety, removal, disposal and emission standards for asbestos abatement.
- C. Work covered by this section includes the handling of non-friable materials containing asbestos, procedures, and equipment required to protect workers and the environment from airborne asbestos fibers during the work described. Existing materials identified in the report, which are to be removed as part of this project, have been determined by testing, to contain asbestos.
- D. The Contractor shall provide a "competent person" as defined in 29 CFR 1926.1101 and at least one trained NESHAP person onsite during the removal. In addition, the American Red Cross or equivalent shall certify that at least one of the Contractor's site crewmembers at each work area have been trained in basic first aid and CPR.
- E. Any dimensions, quantities, or locations are approximate, included solely to provide general information to the Contractor. The Contractor is responsible for removal of all asbestos containing materials (ACM) indicated without regard to accuracy of any such dimensions, quantities, or locations.
- F. Prior to commencing work, the Contractor's "competent person" shall identify asbestos hazards in the workplace, select the appropriate control strategy, take corrective measures to eliminate such hazards, and conduct an inspection to determine that the material to be removed is intact and will likely remain intact during removal and disposal.
- G. Work includes cleaning and decontaminating all areas where asbestos containing materials (ACM) are removed, are proper transportation and disposal of all ACM waste. The Contractor shall use a landfill permitted to accept asbestos.
- H. The Contractor shall submit a required EPA-NESHAP "Courtesy" Notification of Renovation or the required 10-day Notification of Renovation.

1.2 SCOPE OF WORK

- A. The Contractor shall complete all abatement work and meet all criteria for removal, cleanup and disposal as provided herein. The Contractor's responsibilities shall include removal, transportation, and receipt for disposal at an approved landfill of all identified asbestos containing or contaminated materials (ACM).
- B. The Contractor shall be responsible for securing openings or access points to all abatement work areas. The Contractor shut down the HVAC system. A drop sheet of 6-mil poly shall be placed on the floor and ground at the areas of removal to protect the landscape and to facilitate clean up of any debris that may fall from the roof during removal.
- C. The Contractor shall conduct all work in a safe and professional manner insuring that the building occupants, workers, environment and the public are not exposed to hazardous levels of air borne asbestos. The Contractor shall make restitution for any and all damages caused by abatement activities to any of the building's components and systems.
- D. All asbestos-containing materials listed are subject to Class II removal requirements as defined by 29 CFR 1926.1101. The Contractor shall ensure that the following Engineering Controls for non-friable ACM materials removal work practices are followed:
 - 1. Shut down the HVAC system.
 - 2. ACM material shall be removed in an intact state.
 - 3. ACM materials shall be continuously misted during removal.
 - 4. A HEPA dust collector shall collect all dust resulting from any and all inadvertent damage to ACM materials during the removal process.
 - 5. ACM material that has been removed shall not be dropped or thrown to the ground. The material shall be carried by hand to a closed disposal transport container in such manner so as to preclude dispersion of dust. All removed material must be removed to the closed disposal transport container no later than at the end of the work shift.
- E. Alternative Work Practices and Controls. The Contractor may use different or modified engineering and work practices if the following provisions are used.
 - 1. The Contractor demonstrates by providing data representing past employee exposure using similar removal methods for similar conditions under which will be used and that employee exposure will not exceed the PELs under any anticipated circumstances.
- F. Respirator Protection General. The Contractor shall implement a respiratory program in accordance with OSHA 29 CFR 1910.134. For employees who use respirators required by this section, the employer shall provide respirators that comply with the requirements of this paragraph. Respirators shall be used during:
 - 1. Class II work when ACM is not removed in a substantially intact state.
 - 2. Class II and III asbestos work that is not performed using wet methods.
 - 3. Class II and Class III asbestos work for which a negative-exposure assessment has not been conducted.
- G. Employee Information and Training.

1. The employer shall, at no cost to the employee, institute and ensure employee participation a training program for all employees who are likely to be exposed in excess of a PEL and for all employees who perform Class I through IV asbestos operations.
 2. Training shall be provided prior to commencing work and at least annually thereafter (if project duration exceeds one year). Class II work training shall include at a minimum the equivalent in curriculum, training method, and length to the EPA's Model Accreditation Program for Workers.
- H. Housekeeping: When vacuuming methods are selected, HEPA filtered vacuuming equipment shall be used. The equipment shall be used and emptied in a manner that minimizes the re-entry of asbestos into the workplace.

1.2.1 Asbestos Abatement

- A. Removal procedures shall be conducted in accordance with OSHA regulations and this Document. Contractor personnel removing or disturbing ACM shall be required, at a minimum; to wear a HEPA filtered negative pressure air purifying respirator unless a Negative Exposure Assessment (NEA) is provided demonstrating fiber control during removal of ACM materials.
- B. If the NEA and employee monitoring are below the PEL of 0.1 fibers per cubic centimeter (f/cc) 8-hour TWA, and 1.0 (f/cc) 30-minute excursion limit, with proper work practices, the respirator program with medical surveillance will not apply.

1.3 SUBMITTALS

- A. The following shall be submitted to and accepted by the Architect prior to the start of the project or commencing work involving ACM materials:
 1. Contractor's anticipated schedule shall be submitted to the Architect with the pre-work submittals.
 2. Proof that all permits and notifications have been secured in conjunction with removal, hauling, or disposal of ACM material and that timeliness of such actions meets requirements of federal, state, regional, and local authorities.
 3. Documentation that workers are currently certified and trained per applicable requirements for anticipated work activities for ACM materials removal.
 4. Documentation that each supervisor is currently certified as an Asbestos Supervisor per EPA 40 CFR 763 or a Competent Person as required by OSHA.
- B. The Contractor shall submit post-work project documentation to the Architect within 10 days of completion of asbestos abatement. Post-work documentation shall include at least the following:
 1. All permits and notifications.
 2. All waste shipment records.
 3. Daily work logs.

4. All air monitoring analytical results.

1.4 JOB CONDITIONS

- A. For each asbestos abatement area, asbestos abatement shall be scheduled and completed prior to all other construction activities that could have an adverse affect on the ACM. Damage to the building or adjacent properties, etc. caused by the Contractor shall be repaired at no additional expense to Owner.
- B. Work areas shall be secured or shall be under the direct control of the Contractor at all times. Securing work areas includes locking access, removing any safety hazards, and securing all waste and equipment.

1.5 QUALITY CONTROL

- A. The Contractor is responsible for performing all personal air monitoring as required by OSHA 29 CFR 1910.
 1. A “competent person”, “certified asbestos supervisor”, “NIOSH 582 Reader” or accepted equivalent training with a minimum of six (6) months experience is required for the Contractor's monitoring technician.
 2. An accredited laboratory shall analyze all samples taken by the Contractor. The lab is subject to acceptance by the Owner and Architect. Analytical results shall be made available to the Owner and Architect within 24 hours of sample completion.
 3. Control limit for workers and inside the work area shall be one half of the PEL ($0.1 \text{ f/cc} \times 0.5 = 0.05 \text{ f/cc}$) times the respiratory protection factor of the least protective respirator used. $[(\text{PEL})(0.5)(\text{RPF})] = \text{Control Limits}$.
- B. Work Practices as a Function of Airborne Fiber Concentrations:
 1. Work Practices and Engineering Controls for Class II ACM removal procedures include misting water, wet sweeping and HEPA vacuums. Protective equipment (respirators, disposal coveralls) shall be continually used throughout the process for removal of non-intact roofing materials.
 2. Should the air samples reach or exceed the control limit, abatement work shall stop, respirators shall be changed (if necessary), and cleaning operations shall be initiated. Abatement shall not resume until the fiber concentration is reduced below the control limit.

1.6 APPLICABLE CODES, REGULATIONS, AND PUBLICATIONS

- A. All applicable codes, regulations, and standards have the same force and effect, and are made a part of the contract documents as if copied directly into the contract documents, or as if published copies are bound herewith. The Contractor is responsible and liable for full compliance with all applicable federal, state, and local regulations.

2.0 PRODUCTS

2.1 EQUIPMENT AND MATERIALS

- A. The Contractor shall provide equipment and materials as listed below and any deviations shall be submitted to the Project Monitor for acceptance. The applicable Material Safety Data Sheet (MSDS) or U.S. Department of Labor Approval shall accompany all such submittals.
- B. The Mine Safety and Health Administration (MSHA) or National Institute for Occupational Safety and Health (NIOSH) shall approve all respirators.
 - 1. Use, at a minimum, negative pressure half face respirator equipped with HEPA filtration cartridges during non-intact ACM materials removal, manual non-friable, or cut methods. Respiratory protection shall be increased as required by OSHA 29 CFR 1926.1101 Construction Standard when daily air monitoring indicates.
- C. Provide goggles to personnel engaged in ACM materials removal operations when the use of a full-face respirator is not required.
- D. Provide “danger” signs and labeled barricades at all approaches to work areas. Locate signs where personnel may read the sign and take the necessary protective steps required before entering the area. Provide labels and affix to all asbestos materials, scrap, waste, debris, and other products contaminated with asbestos.
 - 1. Danger signs shall conform to OSHA 29 CFR 1910.145(d)(4).
 - 2. Warning Labels shall be sufficient size to be clearly legible and read:

**DANGER
CONTAINS ASBESTOS FIBERS
AVOID CREATING DUST
BREATHING ASBESTOS DUST MAY
CAUSE SERIOUS BODILY HARM**

- 3. Warning Signs shall be sufficient size to be clearly legible and read:

**DANGER
ASBESTOS
CANCER AND LUNG DISEASE HAZARD
AUTHORIZED PERSONNEL ONLY
RESPIRATORS AND PROTECTIVE CLOTHING
ARE REQUIRED IN THIS AREA**

- E. Polyethylene barriers (sheeting) shall be 6-mil thickness and sealed with duct tape as necessary to prevent ACM contamination. The Contractor shall stop work and immediately repair any tears or punctures in sheeting.

3.0 EXECUTION

3.1 INSPECTION

- A. While performing asbestos related work, the Contractor shall be subject to on-site inspection. Work found to be in violation of this Document will be given a stop work order immediately and such order shall remain in effect until the violation is resolved. Standby time, additional monitoring, and laboratory analyses required to resolve the violation shall be at the Contractor's expense.

3.2 ASBESTOS REMOVAL

- A. Spray asbestos material with water using equipment capable of providing a "mist" application to reduce release of fibers. Spray asbestos material repeatedly during work process to maintain wet condition and minimize asbestos fiber dispersion. Removed ACM shall be to the closed receptacle, minimizing breakage and fiber release. All ACM material removed shall be cleaned up and secured by the end of each workday. No debris, unsecured equipment, tools, etc. shall remain on the work site past the end of each workday.

Removal surfaces shall be thoroughly cleaned with wet sweeping (no dry sweeping is allowed) until no traces of ACM can be seen.

3.3 WASTE REMOVAL FROM THE WORK AREA

- A. Gross asbestos debris shall be removed and cleaned up by the end of each workday. All residues shall be removed by wet sweeping or HEPA vacuuming and disposed of as asbestos containing material.
- B. All intact ACM removed from the work area shall be placed directly into the disposal transport container, which shall be lined and covered with a minimum of one (1) layer of 6-mil polyethylene.
- C. All non-intact ACM removed from the work area shall be placed directly into the disposal transport container, which shall be lined and sealed with two (2) layers of 6-mil polyethylene.

3.4 CLEANUP OF WORK AREAS

- A. During this work the surfaces being cleaned shall be kept wet. During cleaning, critical barriers shall remain in place and HVAC systems shall remain shut down, locked-out and sealed. Project Monitor shall be notified of any deviation from these procedures.

Clean all other surfaces in the work area and any other contaminated areas with water and/or with HEPA vacuum equipment. After cleaning the work area, allow surfaces to dry completely. Sealed containers and equipment used shall be included in the clean-up and removed from work areas.

3.5 WASTE DISPOSAL

- A. Transport labeled and sealed containers to the authorized site. Procedures for transport and disposal shall comply with 40 CFR 61 Subpart M (NESHAP); 49 CFR Subchapter C (HMTA); and state, regional and local standards and regulations.

- B. Submit Waste Shipment Record (WSR) or documentation of disposal at the landfill to the Architect.

3.6 MEDICAL SURVEILLANCE

- A. The Contractor shall provide medical surveillance to employees or agents that may be exposed to asbestos levels in excess of 0.10 f/cc during removal of ACM.
- B. Medical Surveillance shall include at a minimum:
 - 1. A work/medical history to elicit symptomatology of respiratory disease.
 - 2. A chest X-ray evaluated by a Certified B-reader.
 - 3. A pulmonary function test interpreted by a Certified Pulmonary Specialist.
 - 4. A physician's exam of the employee.

END OF SECTION 028211

THIS PAGE INTENTIONALLY BLANK

SECTION 028333 – LEAD-BASED PAINT REMOVAL AND DISPOSAL

PART 1 - GENERAL

1.1 DESCRIPTION

This Section specifies abatement and disposal of lead-based paint (LBP) and controls needed to limit occupational and environmental exposure to lead hazards. This Section shall be used in conjunction with the Jefferson Elementary School Pre-Renovation Survey – Asbestos and Lead-Based Paint Testing Report prepared by Atlas Technical Consultants, dated January 19, 2023, and contained in Appendix B of this Project Manual.

1.2 RELATED WORK

- A. Section 017329, Cutting and Patching.
- B. Section 024119, Selective Structure Demolition.

1.3 APPLICABLE PUBLICATIONS

- A. The publications listed below form a part of this specification to the extent referenced. The publications are referred to in the text by basic designation only.
- B. Code of Federal Regulations (CFR):
 - CFR 29 Part 1910 Occupational Safety and Health Standards
 - CFR 29 Part 1926 Safety and Health Regulations for Construction
 - CFR 40 Part 260 Hazardous Waste Management System: General

1.4 DEFINITIONS

- A. Action Level: Employee exposure, without regard to use of respirations, to an airborne concentration of lead of 30 micrograms per cubic meter of air averaged over an 8-hour period. As used in this section, “30 micrograms per cubic meter of air” refers to the action level.
- B. Area Monitoring: Sampling of lead concentrations within the lead control area and inside the physical boundaries which is representative of the airborne lead concentrations which may reach the breathing zone of personnel potentially exposed to lead.
- C. Physical Boundary: Area physically roped or partitioned off around an enclosed lead control area to limit unauthorized entry of personnel. As used in this section, “inside boundary” shall mean the same as “outside lead control area.”

- D. Competent Person: A person capable of identifying lead hazards in the work area and is authorized by the contractor to take corrective action.
- E. Eight-Hour Time Weighted Average (TWA): Airborne concentration of lead averaged over an 8-hour workday to which an employee is exposed.
- F. High Efficiency Particulate Air (HEPA) Filter Equipment: HEPA filtered vacuuming equipment with a UL 586 filter system capable of collecting and retaining lead-contaminated paint dust. A high efficiency particulate filter means 99.97 percent efficient against 0.3 micron size particles.
- G. Lead: Metallic lead, inorganic lead compounds, and organic lead soaps. Excluded from this definition are other organic lead compounds.
- H. Lead Control Area: An enclosed area or structure with full containment to prevent the spread of lead dust, paint chips, or debris of lead-containing paint removal operations. The lead control area is isolated by physical boundaries to prevent unauthorized entry of personnel.
- I. Lead Permissible Exposure Limit (PEL): Fifty micrograms per cubic meter of air as an 8-hour time weighted average as determined by 29 CFR 1910.1025. If an employee is exposed for more than 8 hours in a work day, the PEL shall be determined by the following formula. $PEL \text{ (micrograms/cubic meter of air)} = 400/\text{No. of hrs worked per day}$.
- J. Personnel Monitoring: Sampling of lead concentrations within the breathing zone of an employee to determine the 8-hour time weighted average concentration in accordance with 29 CFR 1910.1025. Samples shall be representative of the employee's work tasks. Breathing zone shall be considered an area within a hemisphere, forward of the shoulders, with a radius of 150 mm to 225 mm (6 to 9 inches) and the center at the nose or mouth of an employee.

1.5 QUALITY ASSURANCE

- A. The contractor shall conform to all applicable OSHA regulations related to exposure and removal of lead containing paint.
- B. Training: Train each employee performing paint removal, disposal, and air sampling operations prior to the time of initial job assignment, in accordance with 29 CFR 1926.62.
- C. Safety and Health Compliance:
 - 1. In addition to the detailed requirements of this specification, comply with laws, ordinances, rules, and regulations of federal, state, and local authorities regarding removing, handling, storing, transporting, and disposing of lead waste materials. Comply with the applicable requirements of the current issue of 29 CFR 1910.1025.

PART 3 EXECUTION

3.1 PROTECTION

- A. Lead Control Area Requirements.

- B. Lead Control Area Requirements.
 - 1. Establish a lead control area by completely enclosing with containment screens the area or structure where lead-containing paint removal operations will be performed.
 - 2. Contain removal operations by the use of a negative pressure full containment system with at least one change room and with HEPA filtered exhaust.

- C. Protection of Existing Work to Remain: Perform paint removal work without damage or contamination of adjacent areas. Where existing work is damaged or contaminated, restore work to its original condition.

- D. Boundary Requirements: Provide physical boundaries around the lead control area by roping off the area or providing curtains, portable partitions or other enclosures to ensure that airborne concentrations of lead will not reach 30 micrograms per cubic meter of air outside of the lead control area.

- E. Heating, Ventilating and Air Conditioning (HVAC) Systems: Shut down, lock out, and isolate HVAC systems that supply, exhaust, or pass through the lead control areas. Seal intake and exhaust vents in the lead control area with 6-mil plastic sheet and tape. Seal seams in HVAC components that pass through the lead control area.

- F. Mechanical Ventilation System:
 - 1. Use adequate ventilation to control personnel exposure to lead in accordance with 29 CFR 1926.57.
 - 2. To the extent feasible, use fixed local exhaust ventilation connected to HEPA filters or other collection systems, approved by CFR 29 1926. Local exhaust ventilation systems shall be designed, constructed, installed, and maintained in accordance with ANSI Z9.2.
 - 3. If air from exhaust ventilation is recirculated into the work place, the system shall have a high efficiency filter with reliable back-up filter and controls to monitor the concentration of lead in the return air and to bypass the recirculation system automatically if it fails. Air may be recirculated only where exhaust to the outside is not feasible.

- G. Personnel Protection: Personnel shall wear and use protective clothing and equipment as specified herein. Eating, smoking, or drinking is not permitted in the lead control area. No one will be permitted in the lead control area unless they have been given appropriate training and protective equipment.

3.2 WORK PROCEDURES

- A. Perform removal of lead-containing paint in accordance with applicable OSHA regulations. Use procedures and equipment required to limit occupational and environmental exposure to lead when lead-containing paint is removed in accordance with 29 CFR 1926.62, except as specified herein. Dispose of removed paint chips and associated waste in compliance with Environmental Protection Agency (EPA), federal, state, and local requirements.

B. Monitoring: Monitoring of airborne concentrations of lead shall be in accordance with 29 CFR 1910.1025.

C. Monitoring During Paint Removal Work:

1. Perform personal and area monitoring during the entire paint removal operation. Sufficient area monitoring shall be conducted at the physical boundary to ensure unprotected personnel are not exposed above 30 micrograms per cubic meter of air at all times.

3.3 LEAD-CONTAINING PAINT REMOVAL

- A. Remove paint within the remodeled areas designed on the drawings where cutting and connection to existing conditions require removal of existing lead paint coverings. Take whatever precautions are necessary to minimize damage to the underlying substrate.
- B. Indoor Lead Paint Removal: Select paint removal processes to minimize contamination of work areas with lead-contaminated dust or other lead-contaminated debris/waste. Perform manual sanding and scraping to the maximum extent feasible.
- C. Mechanical Paint Removal and Blast Cleaning: Perform mechanical paint removal and blast cleaning in lead control areas using negative pressure full containments with HEPA filtered exhaust. Collect paint residue and spent grit (used abrasive) from blasting operations for disposal in accordance with EPA, state and local requirements.
- D. Outside Lead Paint Removal: Select removal processes to minimize contamination of work areas with lead-contaminated dust or other lead-contaminated debris/waste. Perform manual sanding and scraping to the maximum extent feasible.

3.4 CLEANUP AND DISPOSAL

- A. Cleanup: Maintain surfaces of the lead control area free of accumulations of paint chips and dust. Restrict the spread of dust and debris; keep waste from being distributed over the work area. Do not dry sweep or use compressed air to clean up the area. At the end of each shift and when the paint removal operation has been completed, clean the area of visible lead paint contamination by vacuuming with a HEPA filtered vacuum cleaner and wet mopping the area.
- B. Certification: The Contractor shall certify in writing that the inside and outside the lead control area air monitoring samples are less than 30 micrograms per cubic meter of air, the respiratory protection for the employees was adequate, the work procedures were performed in accordance with 29 CFR 1926.62, and that there were no visible accumulations of lead-contaminated paint and dust on the worksite.
- C. Disposal:

1. Collect lead-contaminated waste, scrap, debris, bags, containers, equipment, and lead-contaminated clothing, which may produce airborne concentrations of lead particles.
2. Handle, store, transport, and dispose lead or lead-contaminated waste in accordance with 40 CFR 260, 40 CFR 261, 40 CFR 262, 40 CFR 263, 40 CFR 264, and 40 CFR 265. Comply with land disposal restriction notification requirements as required by 40 CFR 268.
3. Disposal Documentation Submit written evidence that the hazardous waste treatment, storage, or disposal facility (TSD) is approved for lead disposal by the EPA and state or local regulatory agencies. Submit one copy of the completed manifest, signed and dated by the initial transporter in accordance with 40 CFR 262.

END OF SECTION 028333

THIS PAGE INTENTIONALLY BLANK

SECTION 033000 - CAST-IN-PLACE CONCRETE

PART 1 - GENERAL

1.1 RELATED DOCUMENTS

- A. Drawings and general provisions of the Contract, including General and Supplementary Conditions and Division 01 Specification Sections, apply to this Section.
- B. Divisions 200 and 700 of the Idaho Standards for Public Works Construction (ISPWC), 2012 Edition, also apply to site / civil concrete construction.

1.2 SUMMARY

- A. This Section specifies cast-in place concrete, including formwork, reinforcement, concrete materials, mixture design, placement procedures, and finishes, for the following:
 - 1. Footings.
 - 2. Foundation walls.
 - 3. Slabs-on-grade (interior).
 - 4. Concrete on metal deck.
 - 5. Concrete curbs and pads.
 - 6. Incidental site concrete (not covered in Section 321313).
 - 7. Vapor retarder.
 - 8. Geo-foam blocks.
- B. Related sections include Section 079200 – Joint Sealants and Section 321313 – Site Concrete.

1.3 DEFINITIONS

- A. Cementitious Materials: Portland cement.

1.4 SUBMITTALS

- A. Product Data: For each type of product indicated.
- B. Design Mixtures: For each concrete mixture. Submit alternate design mixtures when characteristics of materials, Project conditions, weather, test results, or other circumstances warrant adjustments.
- C. Steel Reinforcement Shop Drawings: Placing drawings that detail fabrication, bending, and placement. Include bar sizes, lengths, material, grade, bar schedules, stirrup spacing, bent bar diagrams, bar arrangement, splices and laps, mechanical connections, tie spacing, hoop spacing, and supports for concrete reinforcement.

1. Corner bars for providing continuity of horizontal reinforcing around footing, foundation wall, and other concrete item corners are required and shall be shown on shop drawings.
 2. Approval of shop drawings by the Architect shall not relieve the Contractor of providing all reinforcing noted, shown, or implied by the project Contract Documents.
- D. Slab-on-grade Control & Construction Joint Layout Drawings: Plan drawings that include foundation walls, column isolations, recessed slabs, and other items that define slab extents. Joints shall be located at column isolations, re-entrant corners, etc. and spaced equally between, subject to the spacing requirements shown on the Drawings or at a maximum of 10' x 10' grid spacing if not shown on the Drawings. Submit layout to Architect & Engineer for review prior to slab placement.
- E. Vapor Retarder and Related Accessories.
- F. Curing and Sealing Materials.

1.5 QUALITY ASSURANCE

- A. Installer Qualifications: A qualified installer who employs on Project personnel qualified as ACI-certified Flatwork Technician and Finisher and a supervisor who is an ACI-certified Concrete Flatwork Technician or has 5 years of documented experience.
- B. Manufacturer Qualifications: A firm experienced in manufacturing ready-mixed concrete products and that complies with ASTM C 94/C 94M requirements for production facilities and equipment.
1. Manufacturer certified according to NRMCA's "Certification of Ready Mixed Concrete Production Facilities or submit testing procedures and differenced in procedure from certification requirements."
- C. Testing Agency Qualifications: An independent agency, qualified according to ASTM C 1077 and ASTM E 329 for testing indicated.
1. Personnel conducting field tests shall be qualified as ACI Concrete Field-Testing Technician, Grade 1, according to ACI CP-1 or an equivalent certification program.
 2. Personnel performing laboratory tests shall be ACI-certified Concrete Strength Testing Technician and Concrete Laboratory Testing Technician - Grade I. Testing Agency laboratory supervisor shall be an ACI-certified Concrete Laboratory Testing Technician - Grade II.
- D. Source Limitations: Obtain each type or class of cementitious material of the same brand from the same manufacturer's plant, obtain aggregate from one source, and obtain admixtures through one source from a single manufacturer.
- E. ACI Publications: Comply with the following American Concrete Institute (ACI) unless modified by requirements in the Contract Documents:
1. ACI 301, "Specification for Structural Concrete," Sections 1 through 5.
 2. ACI 117, "Specifications for Tolerances for Concrete Construction and Materials."

- C. Comply with all applicable portions of the International Building Code, 2018 Edition, Chapter 19.
- D. Concrete Testing Service: The Owner will engage a qualified independent testing agency to perform material evaluation tests and to design concrete mixtures.
 - 1. Materials and installed work may require testing and retesting at any time during progress of Work. Retesting of rejected materials for installed Work shall be done at Contractor's expense.
- E. Special Inspections: The Owner shall engage an inspection agency to provide special inspection per Structural Notes on Drawings and as required by the International Building Code. Costs for such inspection shall be paid directly to the inspection agency by the Owner.

1.6 DELIVERY, STORAGE, AND HANDLING

- A. Steel Reinforcement: Deliver, store, and handle steel reinforcement to prevent bending and damage.

PART 2 - PRODUCTS

2.1 MANUFACTURERS

- A. In other Part 2 articles where titles below introduce lists, the following requirements apply to product selection:
 - 1. Products: Subject to compliance with requirements, provide one of the products specified.
 - 2. Manufacturers: Subject to compliance with requirements, provide products by one of the manufacturers specified.
- B. Products and/or manufacturers other than those specified are subject to the Architect's approval prior to bidding.

2.2 FORM-FACING MATERIALS

- A. Smooth-Formed Finished Concrete: Form-facing panels that will provide continuous, true, and smooth concrete surfaces. Furnish in largest practicable sizes to minimize number of joints.
 - 1. Plywood, metal, or other approved panel materials.
 - 2. Exterior-grade plywood panels, suitable for concrete forms, complying with DOC PS 1, and as follows:
 - a. High-density overlay, Class 1 or better.
 - b. Medium-density overlay, Class 1 or better; mill-release agent treated and edge sealed.
 - c. Structural 1, B-B or better; mill oiled and edge sealed.

- d. B-B (Concrete Form), Class 1 or better; mill oiled and edge sealed.
- B. Rough-Formed Finished Concrete: Plywood, lumber, metal, or another approved material. Provide lumber dressed on at least two edges and one side for tight fit.
- C. Void Forms: Biodegradable paper surface, treated for moisture resistance, structurally sufficient to support weight of plastic concrete and other superimposed loads.
- D. Form-Release Agent: Commercially formulated form-release agent that will not bond with, stain, or adversely affect concrete surfaces and will not impair subsequent treatments of concrete surfaces.
 - 1. Formulate form-release agent with rust inhibitor for steel form-facing materials.
- E. Form Ties: Factory-fabricated, removable or snap-off metal or glass-fiber-reinforced plastic form ties designed to resist lateral pressure of fresh concrete on forms and to prevent spalling of concrete on removal.
 - 1. Furnish units that will leave no corrodible metal closer than 1 inch (25 mm) to the plane of exposed concrete surface.
 - 2. Furnish ties that, when removed, will leave holes no larger than 1 inch (25 mm) in diameter in concrete surface.
 - 3. Furnish ties with integral water-barrier plates to walls indicated to receive dampproofing or waterproofing, if any.

2.3 STEEL REINFORCEMENT

- A. Reinforcing Bars: ASTM A 615/A 615M, Grade 60 (Grade 420), deformed.
- B. Plain-Steel Wire: ASTM A 82, as drawn galvanized.
- C. Plain-Steel Welded Wire Reinforcement: ASTM A 185, plain, fabricated from as-drawn steel wire into flat sheets.

2.4 REINFORCEMENT ACCESSORIES

- A. Joint Dowel Bars: ASTM A 615/A 615M, Grade 60 (Grade 420), plain-steel bars, cut bars true to length with ends square and free of burrs.
- B. Bar Supports: Bolsters, chairs, spacers, and other devices for spacing, supporting, and fastening reinforcing bars and welded wire reinforcement in place. Manufacture bar supports from steel wire, plastic, or precast concrete according to CRSI's "Manual of Standard Practice," of greater compressive strength than concrete and as follows:
 - 1. For concrete surfaces exposed to view where legs of wire bar supports contact forms, use CRSI Class 1 plastic-protected steel wire or CRSI Class 2 stainless-steel bar supports.

2.5 CONCRETE MATERIALS

- A. Cementitious Material: Use the following cementitious materials, of the same type, brand, and source, throughout Project:
 - 1. Portland Cement: ASTM C 150, Type I or II gray.
 - a. Fly Ash: ASTM C 618, Class F.
- B. Normal-Weight Aggregates: ASTM C 33, Class 3S coarse aggregate, graded. Provide aggregates from a single source with documented service record data of at least 10 years' satisfactory service in similar applications and service conditions using similar aggregates and cementitious materials.
 - 1. Maximum Coarse-Aggregate Size: 3/4 inch (19mm) nominal.
 - 2. Fine Aggregate: Free of materials with deleterious reactivity to alkali in cement.
- C. Water: ASTM C 94/C 94M and potable.

2.6 ADMIXTURES

- A. Air-Entraining Admixture: ASTM C 260.
- B. Chemical Admixtures: Provide admixtures certified by manufacturer to be compatible with other admixtures and that will not contribute water-soluble chloride. Do not use calcium chloride or admixtures containing calcium chloride.
 - 1. Water-Reducing Admixture: ASTM C 494/C 494M, Type A.
 - 2. Retarding Admixture: ASTM C 494/C 494M, Type B.
 - 3. Water-Reducing and Retarding Admixture: ASTM C 494/C 494M, Type D.
 - 4. High-Range, Water-Reducing Admixture: ASTM C 494/C 494M, Type F.

2.7 VAPOR RETARDERS

- A. Plastic Vapor Retarder: ASTM E 1745, Class A. Include manufacturer's recommended adhesive or pressure-sensitive tape and penetration boots or seals. Include double sided Butyl tape for sealing vapor retarder to foundation wall equivalent to W.R. Meadows Med-cure.
 - 1. Products:
 - a. Fortifiber Corporation; Moistop Ultra 15.
 - b. Raven Industries Inc.; Vapor Block 15.
 - c. Meadows, W.R., Inc.; Perminator 15 mil.
 - d. Stego Industries; StegoWrap 15 mil.
 - e. Reef Industries Inc.; Griffolyn Type-105.

2.8 FLOOR AND SLAB TREATMENTS

- A. Penetrating Liquid Floor Treatment: Clear, chemically reactive, waterborne solution of inorganic silicate or silicate materials and proprietary components; odorless; colorless; that penetrates, hardens, and densifies concrete surfaces.
 - 1. Products:
 - a. Dayton Superior Corporation; Day-Chem Sure Hard.
 - b. L&M Construction Chemicals, Inc.; Seal Hard.
 - c. Meadows, W. R., Inc.; Liqui-Hard.

2.9 CURING MATERIALS

- A. Evaporation Retarder: Waterborne, monomolecular film forming, manufactured for application to fresh concrete.
 - 1. Products:
 - a. Dayton Superior Corporation; Sure Film.
 - b. L&M Construction Chemicals, Inc.; E-Con.
 - c. Meadows, W. R., Inc.; Sealtight Evapre.
- B. Clear, Waterborne, Membrane-Forming Curing Compound: ASTM C 309, Type 1, Class B, dissipating.
 - 1. Products:
 - a. Dayton Superior Corporation; Day Chem Rez Cure (J-11-W).
 - b. L&M Construction Chemicals, Inc.; L&M Cure R.
 - c. Meadows, W. R., Inc.; 1100 Clear.

2.10 RELATED MATERIALS

- A. Expansion- and Isolation-Joint-Filler Strips: ASTM D 1751, asphalt-saturated cellulosic fiber.
- B. Bonding Agent: ASTM C 1059, Type II, non-redispersible, acrylic emulsion or styrene butadiene.
- C. Joint Sealant: See Section 079200 for control joint sealant product(s).
- D. Geo-foam blocks: ASTM D 6817, EPS15, 0.90 lb./c.f. EPS foam blocks by Atlas Molded Products or equivalent.

2.11 CONCRETE MIXTURES, GENERAL

- A. Prepare design mixtures for each type and strength of concrete, proportioned on the basis of laboratory trial mixture or field test data, or both, according to ACI 301.
 - 1. Use a qualified independent testing agency for preparing and reporting proposed mixture designs based on laboratory trial mixtures.

- B. Cementitious Materials: At footings and foundation walls only, fly ash may be used to reduce the total amount of portland cement which would otherwise be used. Limit percentage, by weight, of cementitious materials other than portland cement in concrete as follows:
 - 1. Fly Ash: 15 percent.
- C. Limit water-soluble, chloride-ion content in hardened concrete to 0.06 percent by weight of cement.
- D. Admixtures: Use admixtures according to manufacturer's written instructions.
 - 1. Use water-reducing or high-range water-reducing admixture in concrete, as required, for placement and workability.
 - 2. Use water-reducing and retarding admixture when required by high temperatures, low humidity, or other adverse placement conditions.
 - 3. Use water-reducing admixture in pumped concrete, concrete for heavy-use industrial slabs and parking structure slabs, concrete required to be watertight, and concrete with a water-cementitious materials ratio below 0.45.

2.12 CONCRETE MIXTURES FOR BUILDING ELEMENTS

- A. Footings: Proportion normal-weight concrete mixture as follows:
 - 1. Minimum Compressive Strength: as shown on Drawings.
 - 2. Maximum Water-Cementitious Materials Ratio: 0.5
 - 3. Slump Limit: 4 inches (100 mm).
 - 4. Air Content: 3% max with hard troweled surface or 6% max when exposed to weather.
- B. Foundation Walls and Retaining Walls: Proportion normal-weight concrete mixture as follows:
 - 1. Minimum Compressive Strength: as shown on Drawings.
 - 2. Maximum Water-Cementitious Materials Ratio: 0.5
 - 3. Slump Limit: 4 inches (100 mm).
 - 4. Air Content: 3% max with hard troweled surface or 6% max when exposed to weather.
- C. Slabs-on-Grade Exterior: Proportion normal-weight concrete mixture as follows:
 - 1. Minimum Compressive Strength: 4,000 psi (31 MPa) at 28 days.
 - 2. Maximum Water - Cementitious Materials Ratio: 0.45.
 - 3. Slump Limit: 4 inches (100 mm).
 - 4. Air Content: 5 percent, plus or minus 1.5 percent at point of delivery.
- D. Slab-on-Grade Interior: Proportion normal-weight concrete mixture as follows:
 - 1. Minimum Compressive Strength: as shown on Drawings.
 - 2. Maximum Water - Cementitious Materials Ratio: 0.45
 - 3. Slump Limit: 4 inches (100 mm). 8 inches for concrete with verified slump of 2 to 4 inches before adding water-reducing admixture.
 - 4. Air Content: 3 percent max. No added entrained air.

- E. Concrete on Metal Deck: Proportion normal-weight concrete mixture as follows:
 - 1. Minimum Compressive Strength: as shown on Drawings.
 - 2. Maximum Water – Cementitious Materials Ratio: 0.45
 - 3. Slump Limit: 4 inches (100 mm). 8 inches for concrete with verified slump of 2 to 4 inches before adding water-reducing admixture.
 - 4. Air Content: 3 percent max. No added entrained air.

2.13 FABRICATING REINFORCEMENT

- A. Fabricate steel reinforcement according to Concrete Reinforcing Steel Institute's (CRSI) "Manual of Standard Practice."
- B. Corner bars for providing continuity of horizontal reinforcing around footing, foundation wall and other concrete item corners are required.

2.14 CONCRETE MIXING

- A. Ready-Mixed Concrete: Measure, batch, mix, and deliver concrete according to ASTM C 94/C 94M, and furnish batch ticket information.
 - 1. When air temperature is between 85 and 90 deg F (30 and 32 deg C), reduce mixing and delivery time from 1-1/2 hours to 75 minutes; when air temperature is above 90 deg F (32 deg C), reduce mixing and delivery time to 60 minutes.

PART 3 - EXECUTION

3.1 FORMWORK

- A. Design, erect, shore, brace, and maintain formwork, according to ACI 301, to support vertical, lateral, static, and dynamic loads, and construction loads that might be applied, until structure can support such loads.
- B. Construct formwork so concrete members and structures are of size, shape, alignment, elevation, and position indicated, within tolerance limits of ACI 117.
- C. Limit concrete surface irregularities, designated by ACI 347R as abrupt or gradual, as follows:
 - 1. Class A, 1/8 inch (3.2 mm) for smooth-formed finished surfaces.
 - 2. Class B, 1/4 inch (6 mm) for rough-formed finished surfaces.
- D. Construct forms tight enough to prevent loss of concrete mortar.
- E. Fabricate forms for easy removal without hammering or prying against concrete surfaces. Provide crush or wrecking plates where stripping may damage cast concrete surfaces. Provide top forms for inclined surfaces steeper than 1.5 horizontal to 1 vertical.

1. Install keyways, reglets, recesses, and the like, for easy removal.
 2. Do not use rust-stained steel form-facing material.
- F. Set edge forms, bulkheads, and intermediate screed strips for slabs to achieve required elevations and slopes in finished concrete surfaces. Provide and secure units to support screed strips; use strike-off templates or compacting-type screeds.
- G. Provide temporary openings for cleanouts and inspection ports where interior area of formwork is inaccessible. Close openings with panels tightly fitted to forms and securely braced to prevent loss of concrete mortar. Locate temporary openings in forms at inconspicuous locations.
- H. Chamfer exterior corners and edges of permanently exposed concrete only if and where indicated.
- I. Form openings, chases, offsets, sinkages, keyways, reglets, blocking, screeds, and bulkheads required in the Work. Determine sizes and locations from trades providing such items.
- J. Clean forms and adjacent surfaces to receive concrete. Remove chips, wood, sawdust, dirt, and other debris just before placing concrete.
- K. Retighten forms and bracing before placing concrete, as required, to prevent mortar leaks and maintain proper alignment.
- L. Coat contact surfaces of forms with form-release agent, according to manufacturer's written instructions, before placing reinforcement.
- M. Install geo-foam blocks in strict compliance with manufacturer requirements and structural details.

3.2 EMBEDDED ITEMS

- A. Place and secure anchorage devices and other embedded items required for adjoining work that is attached to or supported by cast-in-place concrete. Use setting drawings, templates, diagrams, instructions, and directions furnished with items to be embedded.
1. Install anchor rods, accurately located, to elevations required and complying with tolerances in Section 7.5 of AISC's "Code of Standard Practice for Steel Buildings and Bridges."
- B. All sleeves, anchor bolts, dowels, and reinforcing items, together with anchors, weld plates, bearing plates, etc. to be set in concrete, shall be positioned and securely anchored in place prior to placement of concrete. Such items shall not be pushed into freshly placed concrete.
- C. Where work of other sections require openings for passage of pipes, conduits, ducts, and other inserts in the concrete, obtain all dimensions and other information. All necessary pipe sleeves, anchors, or other required inserts shall be accurately installed as part of the work of other sections, according to following requirements:
1. Conduits or Pipes:

- a. Footings:
 - 1) Locate so as not to reduce the strength of concrete. In no case place pipes, other than conduits, in a footing 4-1/2" thick or less. Conduit buried in a concrete footing shall not have an outside diameter greater than 1/3 the footing thickness nor be placed below the bottom reinforcing steel or over the top reinforcing steel.
 - b. Slab on Grade or Elevated Slabs:
 - 1) In no case place pipes or conduits in an elevated slab or slab on grade.
- 2. Conduits and pipes of aluminum shall not be embedded in structural concrete unless coated or covered to prevent aluminum-concrete reaction or electrolytic action between aluminum and reinforcing steel.
 - 3. Sleeves: Pipe sleeves may pass through slabs or walls if not exposed to rusting or other deterioration and are of uncoated or galvanized iron or steel. Provide sleeves of diameter large enough to pass any hub or coupling on pipe, including any insulation.
 - 4. Conduits: Conduits may be embedded in walls only if the outside diameter does not exceed 1/3 the wall thickness, are spaced no closer than 3 diameters on centers and do not impair the strength of the structure.
 - 5. Clusters of Conduits:
 - a. Clusters of conduits embedded in a concrete slab shall not exceed 6 conduits per cluster and each conduit per cluster shall be individually spaced as per the above requirements. Conduit clusters shall be reviewed and approved by the structural engineer of record prior to the installation of the conduits.
 - b. If more than one conduit cluster is required in a specific area of the slab, routing and spacing of the clusters shall be reviewed and approved by the structural engineer of record prior to the installation of the conduits.
 - c. At no time shall the quantity and routing of clusters of conduits impair the strength of the concrete construction.

3.3 REMOVING AND REUSING FORMS

- A. General: Formwork for sides of beams, walls, columns, and similar parts of the Work that does not support weight of concrete may be removed after cumulatively curing at not less than 50 deg. F (10 deg. C) for 24 hours after placing concrete, if concrete is hard enough to not be damaged by form-removal operations and curing and protection operations are maintained.
 - 1. Leave formwork for beam soffits, joists, slabs, and other structural elements that supports weight of concrete in place until concrete has achieved at least 70 percent of its 28-day design compressive strength.
 - 2. Remove forms only if shores have been arranged to permit removal of forms without loosening or disturbing shores.
- B. Clean and repair surfaces of forms to be reused in the Work. Split, frayed, delaminated, or otherwise damaged form-facing material will not be acceptable for exposed surfaces. Apply new form-release agent.

- C. When forms are reused, clean surfaces, remove fins and laitance, and tighten to close joints. Align and secure joints to avoid offsets. Do not use patched forms for exposed concrete surfaces unless approved by Architect.

3.4 VAPOR RETARDERS

- A. Plastic Vapor Retarders: Place, protect, and repair vapor retarders according to ASTM E 1643 and manufacturer's written instructions; place sheets in position with longest dimension parallel with direction of pour.
 - 1. Level and compact base material.
 - 2. Place vapor retarder directly under the concrete slab and extend vapor retarder to the perimeter of the slab. If practicable, terminate at top of the slab elevation, otherwise (a) at a point acceptable to the architect or (b) where obstructed by impediments (such as dowels, waterstops, or any other site condition requiring early termination of the vapor retarder). At the point of termination, seal vapor retarder to the foundation wall or obstruction with double sided tape or continuous bead of urethane sealant. At exterior walls, terminate vapor retarder at top of foundation wall prior to installation of insulation.
 - 3. Lap joints 6 inches (150 mm) and seal with manufacturer's recommended tape.
 - 4. Apply seam tape to a clean and dry vapor retarder.
 - 5. Seal all penetrations (including pipes) with tape and / or mastic per manufacturer's instructions.
 - 6. Avoid the use of non-permanent stakes driven through vapor retarder.
 - 7. If non-permanent stakes are driven through vapor retarder, repair as recommended by vapor retarder manufacturer.
 - 8. Repair damaged areas with vapor retarder material of similar (or better) permeance, puncture and tensile.

3.5 STEEL REINFORCEMENT

- A. General: Comply with CRSI's "Manual of Standard Practice" for placing reinforcement.
 - 1. Do not cut or puncture vapor retarder. Repair damage and reseal vapor retarder before placing concrete.
- B. Clean reinforcement of loose rust and mill scale, earth, ice, and other foreign materials that would reduce bond to concrete.
- C. Accurately position, support, and secure reinforcement against displacement. Locate and support reinforcement with bar supports to maintain minimum concrete cover. Do not tack weld crossing reinforcing bars.
- D. Set wire ties with ends directed into concrete, not toward exposed concrete surfaces.
- E. Install welded wire reinforcement in longest practicable lengths on bar supports spaced maximum 3'-0" o.c. to minimize sagging. Lap edges and ends of adjoining sheets at least one mesh spacing. Offset laps of adjoining sheet widths to prevent continuous laps in either direction. Lace overlaps with wire.

3.6 JOINTS

- A. General: Construct joints true to line with faces perpendicular to surface plane of concrete. Joints shall be located at column isolations, re-entrant corners, etc. and spaced equally between, subject to the spacing requirements shown on the Drawings or at a maximum of 10' x 10' grid spacing if not shown on the Drawings. Submit layout to Architect & Engineer for review prior to slab placement.
- B. Construction Joints: Install so strength and appearance of concrete are not impaired, at locations indicated or as approved by Architect.
 - 1. Place joints perpendicular to main reinforcement. Continue reinforcement across construction joints, unless otherwise indicated. Do not continue reinforcement through sides of strip placements of floors and slabs. Coordinate slab joint transfer mechanism requirements with construction documents.
 - 2. Space vertical joints in walls as indicated. Locate joints beside piers integral with walls, near corners, and in concealed locations where possible.
 - 3. Use a bonding agent at locations where fresh concrete is placed against hardened or partially hardened concrete surfaces.
- C. Contraction Joints in Slabs-on-Grade: Form weakened-plane contraction joints, sectioning concrete into areas as indicated and not more than 10' if not shown on the drawings. Construct contraction joints for a depth equal to at least one-fourth of concrete thickness as follows:
 - 1. Tooled Grooved Joints: Form contraction joints in exterior concrete slabs after initial floating by grooving and tooling each edge of joint to a radius of 1/8 inch (3.2 mm). Repeat grooving of contraction joints after applying surface finishes. Eliminate groover tool marks on concrete surfaces.
 - 2. Sawed Joints: Form contraction joints in interior concrete slabs on grade with power saws equipped with shatterproof abrasive or diamond-rimmed blades. Cut 1/8-inch- (3.2-mm-) wide joints into concrete when cutting action will not tear, abrade, or otherwise damage surface and before concrete develops random contraction cracks.
- D. Isolation / Expansion Joints in Slabs-on-Grade: Install joint-filler strips (or insulation where shown in details on drawings) at slab junctions with vertical surfaces, such as column pedestals, foundation walls, grade beams, and other locations, as indicated, and in exterior flatwork where shown or at no more than 30'-0" o.c.
 - 1. Extend joint-filler strips full width and depth of joint, terminating flush with finished concrete surface, unless otherwise indicated.
 - 2. Terminate full-width joint-filler strips not less than 1/2 inch (13 mm) or more than 1 inch (25 mm) below finished concrete surface where joint sealants, specified in Division 07 Section "Joint Sealants," are indicated.
 - 3. Install joint-filler strips in lengths as long as practicable. Where more than one length is required, lace or clip sections together.
- E. Doweled Joints: Install dowel bars and support assemblies at joints if and where indicated. Lubricate or asphalt coat one-half of dowel length to prevent concrete bonding to one side of joint.

3.7 CONCRETE PLACEMENT

- A. Before placing concrete, verify that installation of formwork, reinforcement, and embedded items is complete and that required inspections have been performed.
- B. Do not add water to concrete during delivery, at Project site, or during placement unless approved by Architect in writing.
- C. Deposit concrete continuously in one layer or in horizontal layers of such thickness that no new concrete will be placed on concrete that has hardened enough to cause seams or planes of weakness. If a section cannot be placed continuously, provide construction joints as indicated. Deposit concrete to avoid segregation.
 - 1. Deposit concrete in horizontal layers of depth to not exceed formwork design pressures and in a manner to avoid inclined construction joints.
 - 2. Consolidate placed concrete with mechanical vibrating equipment according to ACI 301.
 - 3. Do not use vibrators to transport concrete inside forms. Insert and withdraw vibrators vertically at uniformly spaced locations to rapidly penetrate placed layer and at least 6 inches (150 mm) into preceding layer. Do not insert vibrators into lower layers of concrete that have begun to lose plasticity. At each insertion, limit duration of vibration to time necessary to consolidate concrete and complete embedment of reinforcement and other embedded items without causing mixture constituents to segregate.
- D. Deposit and consolidate concrete for floors and slabs in a continuous operation, within limits of construction joints, until placement of a panel or section is complete.
 - 1. Consolidate concrete during placement operations so concrete is thoroughly worked around reinforcement and other embedded items and into corners.
 - 2. Maintain reinforcement in position on chairs during concrete placement.
 - 3. Screed slab surfaces with a straightedge and strike off to correct elevations.
 - 4. Slope surfaces uniformly to drains where required.
 - 5. Begin initial floating using bull floats or darbies to form a uniform and open-textured surface plane, before excess bleedwater appears on the surface. Do not further disturb slab surfaces before starting finishing operations.
- E. Cold-Weather Placement: Comply with ACI 306.1 and as follows. Protect concrete work from physical damage or reduced strength that could be caused by frost, freezing actions, or low temperatures.
 - 1. When average high and low temperature is expected to fall below 40 deg F (4.4 deg C) for three successive days, maintain delivered concrete mixture temperature within the temperature range required by ACI 301.
 - 2. Do not use frozen materials or materials containing ice or snow. Do not place concrete on frozen subgrade or on subgrade containing frozen materials.
 - 3. Do not use calcium chloride, salt, or other materials containing antifreeze agents or chemical accelerators.
- F. Hot-Weather Placement: Comply with ACI 301 and as follows:
 - 1. Maintain concrete temperature below 90 deg F (32 deg C) at time of placement. Chilled mixing water or chopped ice may be used to control temperature, provided water

equivalent of ice is calculated to total amount of mixing water. Using liquid nitrogen to cool concrete is Contractor's option.

2. Fog-spray forms, steel reinforcement, and subgrade just before placing concrete. Keep subgrade uniformly moist without standing water, soft spots, or dry areas.

3.8 FINISHING FORMED SURFACES

- A. Rough-Formed Finish: As-cast concrete texture imparted by form-facing material with tie holes and defects repaired and patched. Remove fins and other projections that exceed specified limits on formed-surface irregularities.
 1. Apply to concrete surfaces not exposed to public view.
- B. Smooth-Formed Finish: As-cast concrete texture imparted by form-facing material, arranged in an orderly and symmetrical manner with a minimum of seams. Repair and patch tie holes and defects. Remove fins and other projections that exceed specified limits on formed-surface irregularities.
 1. Apply to concrete surfaces exposed to public view, including upper portions of foundation walls. Do not rub or "sack" finish exposed concrete.
- C. Related Unformed Surfaces: At tops of walls, horizontal offsets, and similar unformed surfaces adjacent to formed surfaces, strike off smooth and finish with a texture matching adjacent formed surfaces. Continue final surface treatment of formed surfaces uniformly across adjacent unformed surfaces, unless otherwise indicated.

3.9 FINISHING FLOORS AND SLABS

- A. General: Comply with ACI 302.1R recommendations for screeding, restraightening, and finishing operations for concrete surfaces. Do not wet concrete surfaces.
- B. Scratch Finish: While still plastic, texture concrete surface that has been screeded and bull-floated or darbied. Use stiff brushes, brooms, or rakes to produce a profile amplitude of 1/4 inch (6 mm) in 1 direction.
 1. Apply scratch finish to surfaces indicated to receive concrete floor toppings and to receive mortar setting beds for bonded cementitious floor finishes.
- C. Float Finish: Consolidate surface with power-driven floats or by hand floating if area is small or inaccessible to power driven floats. Restraighten, cut down high spots, and fill low spots. Repeat float passes and restraightening until surface is left with a uniform, smooth, granular texture.
 1. Apply float finish to surfaces indicated to receive trowel finish.
- D. Trowel Finish: After applying float finish, apply first troweling and consolidate concrete by hand or power-driven trowel. Continue troweling passes and restraighten until surface is free of trowel marks and uniform in texture and appearance. Grind smooth any surface defects that would telegraph through applied coatings or floor coverings.

1. Apply a trowel finish to surfaces exposed to view or to be covered with resilient flooring, carpet, ceramic or quarry tile set over a cleavage membrane, paint, or another thin-film-finish coating system.
 2. Finish surfaces to the following tolerances, according to ASTM E 1155 (ASTM E 1155M), for a randomly trafficked floor surface:
 - a. Specified overall values of flatness, F(F) 35; and of levelness, F(L) 30; with minimum local values of flatness, F(F) 25; and of levelness, F(L) 20; for interior slabs-on-grade.
- E. Trowel and Fine-Broom Finish: Apply a first trowel finish to surfaces where ceramic or quarry tile is to be installed by either thickset or thin-set method. While concrete is still plastic, slightly scarify surface with a fine broom.
1. Comply with flatness and levelness tolerances for trowel finished floor surfaces.
- F. Broom Finish at Exterior Concrete: Apply a broom finish to exterior concrete sidewalks, curbs, gutters, and elsewhere as indicated.
1. Immediately after trowel finishing, slightly scarify trafficked surface by brooming with fiber-bristle broom perpendicular to main traffic route. Coordinate required final finish with Architect before application.

3.10 MISCELLANEOUS CONCRETE ITEMS

- A. Filling In: Fill in holes and openings left in concrete structures, unless otherwise indicated, after work of other trades is in place. Mix, place, and cure concrete, as specified, to blend with in-place construction. Provide other miscellaneous concrete filling indicated or required to complete the Work.
- B. Curbs: Provide monolithic finish to interior curbs by stripping forms while concrete is still green and by steel-troweling surfaces to a hard, dense finish with corners, intersections, and terminations slightly rounded.
- C. Equipment Bases and Foundations: Provide machine and equipment bases and foundations as shown on Drawings. Set anchor bolts for machines and equipment at correct elevations, complying with diagrams or templates from manufacturer furnishing machines and equipment.

3.11 CONCRETE PROTECTING AND CURING

- A. General: Protect freshly placed concrete from premature drying and excessive cold or hot temperatures. Comply with ACI 306.1 for cold-weather protection and ACI 301 for hot-weather protection during curing.
- B. Evaporation Retarder: Apply evaporation retarder to unformed concrete surfaces if hot, dry, or windy conditions cause moisture loss approaching 0.2 lb/sq. ft. x h (1 kg/sq. m x h) before and during finishing operations. Apply according to manufacturer's written instructions after placing, screeding, and bull floating or darbying concrete, but before float finishing.

- C. Formed Surfaces: Cure formed concrete surfaces, including underside of beams, supported slabs, and other similar surfaces. If forms remain during curing period, moist cure after loosening forms. If removing forms before end of curing period, continue curing for the remainder of the curing period.
- D. Unformed Surfaces: Begin curing immediately after finishing concrete. Cure unformed surfaces, including floors and slabs, concrete floor toppings, and other surfaces.
- E. Cure concrete according to ACI 308.1, by one or a combination of the following methods:
 - 1. Moisture Curing: Keep surfaces continuously moist for not less than seven days with the following materials:
 - a. Water.
 - b. Continuous water-fog spray.
 - c. Absorptive cover, water saturated, and kept continuously wet. Cover concrete surfaces and edges with 12-inch (300-mm) lap over adjacent absorptive covers.
 - 2. Moisture-Retaining-Cover Curing: Cover concrete surfaces with moisture-retaining cover for curing concrete, placed in widest practicable width, with sides and ends lapped at least 12 inches (300 mm), and sealed by waterproof tape or adhesive. Cure for not less than seven days. Immediately repair any holes or tears during curing period using cover material and waterproof tape.
 - a. Moisture cure or use moisture-retaining covers to cure concrete surfaces to receive penetrating liquid floor treatments.
 - b. Cure concrete surfaces to receive floor coverings with either a moisture-retaining cover or a curing compound that the manufacturer certifies will not interfere with bonding of floor covering used on Project.
 - 3. Curing Compound: Apply uniformly in continuous operation by power spray or roller according to manufacturer's written instructions. Recoat areas subjected to heavy rainfall within three hours after initial application. Maintain continuity of coating and repair damage during curing period.
 - a. After curing period has elapsed, remove curing compound without damaging concrete surfaces by method recommended by curing compound manufacturer unless manufacturer certifies curing compound will not interfere with bonding of floor covering used on Project.

3.12 LIQUID FLOOR TREATMENTS

- A. Penetrating Liquid Floor Treatment: Prepare, apply, and finish penetrating liquid floor treatment according to manufacturer's written instructions.
 - 1. Remove curing compounds, sealers, oil, dirt, laitance, and other contaminants and complete surface repairs.
 - 2. Do not apply to concrete that is less than 28 days' old.

3. Apply liquid until surface is saturated, scrubbing into surface until a gel forms; rewet; and repeat brooming or scrubbing. Rinse with water; remove excess material until surface is dry. Apply a second coat in a similar manner if surface is rough or porous.
- B. Sealing Coat: Uniformly apply a continuous sealing coat of curing and sealing compound to hardened concrete by power spray or roller according to manufacturer's written instructions.

3.13 CONCRETE SURFACE REPAIRS

- A. Defective Concrete: Repair and patch defective areas when approved by Architect. Remove and replace concrete that cannot be repaired and patched to Architect's approval.
- B. Patching Mortar: Mix dry-pack patching mortar, consisting of one part portland cement to two and one-half parts fine aggregate passing a No. 16 (1.18-mm) sieve, using only enough water for handling and placing.
- C. Repairing Formed Surfaces: Surface defects include color and texture irregularities, cracks, spalls, air bubbles, honeycombs, rock pockets, fins and other projections on the surface, and stains and other discolorations that cannot be removed by cleaning.
1. Immediately after form removal, cut out honeycombs, rock pockets, and voids more than 1/2 inch (13 mm) in any dimension in solid concrete, but not less than 1 inch (25 mm) in depth. Make edges of cuts perpendicular to concrete surface. Clean, dampen with water, and brush-coat holes and voids with bonding agent. Fill and compact with patching mortar before bonding agent has dried. Fill form-tie voids with patching mortar or cone plugs secured in place with bonding agent.
 2. Repair defects on surfaces exposed to view by blending white portland cement and standard portland cement so that, when dry, patching mortar will match surrounding color. Patch a test area at inconspicuous locations to verify mixture and color match before proceeding with patching. Compact mortar in place and strike off slightly higher than surrounding surface.
 3. Repair defects on concealed formed surfaces that affect concrete's durability and structural performance as determined by Architect.
- D. Repairing Unformed Surfaces: Test unformed surfaces, such as floors and slabs, for finish and verify surface tolerances specified for each surface. Correct low and high areas. Test surfaces sloped to drain for trueness of slope and smoothness; use a sloped template.
1. Repair finished surfaces containing defects. Surface defects include spalls, popouts, honeycombs, rock pockets, crazing and cracks in excess of 0.01 inch (0.25 mm) wide or that penetrate to reinforcement or completely through unreinforced sections regardless of width, and other objectionable conditions.
 2. After concrete has cured at least 14 days, correct high areas by grinding.
 3. Correct localized low areas during or immediately after completing surface finishing operations by cutting out low areas and replacing with patching mortar. Finish repaired areas to blend into adjacent concrete.
 4. Correct other low areas scheduled to receive floor coverings with a repair underlayment. Prepare, mix, and apply repair underlayment and primer according to manufacturer's written instructions to produce a smooth, uniform, plane, and level surface. Feather edges to match adjacent floor elevations.

5. Correct other low areas scheduled to remain exposed with a repair topping. Cut out low areas to ensure a minimum repair topping depth of 1/4 inch (6 mm) to match adjacent floor elevations. Prepare, mix, and apply repair topping and primer according to manufacturer's written instructions to produce a smooth, uniform, plane, and level surface.
 6. Repair defective areas, except random cracks and single holes 1 inch (25 mm) or less in diameter, by cutting out and replacing with fresh concrete. Remove defective areas with clean, square cuts and expose steel reinforcement with at least a 3/4-inch (19-mm) clearance all around. Dampen concrete surfaces in contact with patching concrete and apply bonding agent. Mix patching concrete of same materials and mixture as original concrete except without coarse aggregate. Place, compact, and finish to blend with adjacent finished concrete. Cure in same manner as adjacent concrete.
 7. Repair random cracks and single holes 1 inch (25 mm) or less in diameter with patching mortar. Groove top of cracks and cut out holes to sound concrete and clean off dust, dirt, and loose particles. Dampen cleaned concrete surfaces and apply bonding agent. Place patching mortar before bonding agent has dried. Compact patching mortar and finish to match adjacent concrete. Keep patched area continuously moist for at least 72 hours.
- E. Perform structural repairs of concrete, subject to Architect's approval, using epoxy adhesive and patching mortar.
- F. Repair materials and installation not specified above may be used, subject to Architect's approval.

3.14 FIELD QUALITY CONTROL

- A. Testing and Inspecting: Owner will engage a special inspector (if and as required) and a qualified testing and inspecting agency to perform field tests and inspections as required by applicable codes, by agencies having jurisdiction, and as directed by the Architect, and to prepare test reports.
- B. Inspections may include the following:
1. Steel reinforcement placement.
 2. Steel reinforcement welding.
 3. Headed bolts and studs.
 4. Verification of use of required design mixture.
 5. Concrete placement, including conveying and depositing.
 6. Curing procedures and maintenance of curing temperature.
- C. Concrete Tests: Testing of composite samples of fresh concrete obtained according to ASTM C 172.
1. Testing Frequency: Obtain one composite sample for each day's pour of each concrete mixture exceeding 5 cu. yd., but less than 25 cu. yd., plus one set for each additional 50 cu. yd. or fraction thereof.
 2. Sampling Fresh Concrete: ASTM C 172, except modified for slump to comply with ASTM C 94.
 - a. Slump: ASTM C 143 / C 143M.

- b. Air content: ASTM C 231, pressure method for normal weight concrete.
 - c. Concrete Temperature: ASTM C 1064 / C 1064M.
 - d. Compression Test Specimen: ASTM C 31 / C 31 M; one set of four standard cylinders for each compressive-strength test.
 - e. Compressive-Strength Tests: ASTM C 39 / C 39 M; one specimen tested at 7 days, two specimens tested at 28 days, and one specimen retained in reserve for later testing if required.
 - f. When strength of field-cured cylinders is less than 85 percent of companion laboratory-cured cylinders, evaluate current operations and provide corrective procedures for protecting and curing the in-place concrete.
3. Strength level of concrete will be considered satisfactory only if no individual strength test result falls below specified compressive strength.
- D. Test results will be reported in writing to Contractor, Architect, Structural Engineer, ready-mix producer, and Concrete Contractor. Reports of compressive strength tests shall contain the Project identification name, date of concrete placement, name of concrete testing service, concrete type and class, location of concrete batch in structure, design compressive strength at 28 days, actual, slump, actual air entertainment, and compressive breaking strength, and type of break for both 7-day tests and 28-day tests.
- E. Nondestructive Testing: Impact hammer, sonoscope, or other nondestructive device may be permitted but shall not be used as the sole basis for acceptance or rejection.
- F. Additional Tests: The Testing Agency will make additional tests of in-place concrete when test results indicate specified concrete strengths and other characteristics have not been attained in the structure, as directed by the Architect. The Testing Agency may conduct tests to determine adequacy of concrete by cored cylinders complying with ASTM C 42 / C 42 M, or by other methods as directed.
- G. Measure floor and slab flatness and levelness according to ASTM E 1155 (ASTM E 1155M) within 48 hours of finishing.

END OF SECTION 033000

THIS PAGE INTENTIONALLY BLANK

SECTION 035416 - HYDRAULIC CEMENT UNDERLAYMENT

PART 1 - GENERAL

1.1 RELATED DOCUMENTS

- A. Drawings and general provisions of the Contract, including Division 01 Specification Sections, apply to this Section.

1.2 SUMMARY

- A. This Section includes hydraulic-cement-based underlayment for use below interior floor coverings.

1.3 SUBMITTALS

- A. Product Data: For each type of product indicated.
- B. Manufacturer Certificates: Signed by manufacturers of both underlayment and floor covering system certifying that products are compatible.
- C. Qualification Data: For Installer.

1.4 QUALITY ASSURANCE

- A. Installer Qualifications: Installer who is approved by manufacturer for application of underlayment products required for this Project.
- B. Product Compatibility: Manufacturers of both underlayment and floor covering system certify in writing that products are compatible.
- C. Mockups: Apply hydraulic-cement-based underlayment mockup to demonstrate surface finish, bonding, texture, tolerances, and standard of workmanship.
 - 1. Apply mockup material (approximately 100 sq. ft.) at west entrance alcove to Cafeteria as directed by Architect.
 - 2. Approved mockup may become part of the completed Work if undisturbed at time of Substantial Completion.

1.5 DELIVERY, STORAGE, AND HANDLING

- A. Store materials to comply with manufacturer's written instructions to prevent deterioration from moisture or other detrimental effects.

1.6 PROJECT CONDITIONS

- A. Environmental Limitations: Comply with manufacturer's written instructions for substrate temperature, ambient temperature and humidity, ventilation, and other conditions affecting underlayment performance.
 - 1. Place hydraulic-cement-based underlayments only when ambient temperature and temperature of substrates are between 50 and 80 deg F (10 and 27 deg C).

1.7 COORDINATION

- A. Coordinate application of underlayment with requirements of floor covering products, including adhesives, specified in Division 09 Sections, to ensure compatibility of products.

PART 2 - PRODUCTS

2.1 HYDRAULIC-GYPSUM-CEMENT-BASED UNDERLAYMENTS

- A. Underlayment: Hydraulic-gypsum-cement-based, self-leveling product that can be applied in minimum uniform thicknesses of 3/4 inch up to a thickness of at least 3 inches.
 - 1. Available Products: Subject to compliance with requirements, products that may be incorporated into the Work include, but are not limited to, the following:
 - a. Maxxon Corporation; Gyp-Crete High Performance floor underlayment.
 - b. Equivalent products subject to Architect approval prior to Bid.
 - 2. Cement Binder: ASTM C 150, Portland cement, or hydraulic or blended hydraulic cement as defined by ASTM C 219.
 - 3. Compressive Strength: Not less than 3000 psi at 28 days when tested according to ASTM C 472, with density not less than 115 lbs./cubic ft.
- B. Aggregate: Well-graded, washed gravel, 1/8 to 1/4 inch (3 to 6 mm); or coarse sand as recommended by underlayment manufacturer.
 - 1. Provide aggregate when recommended in writing by underlayment manufacturer for underlayment thickness required.
- C. Water: Potable and at a temperature of not more than 70 deg F (21 deg C).

PART 3 - EXECUTION

3.1 EXAMINATION

- A. Examine substrates, with Installer present, for conditions affecting performance.
 - 1. Proceed with application only after unsatisfactory conditions have been corrected.

3.2 PREPARATION

- A. General: Prepare and clean substrate according to manufacturer's written instructions.
 - 1. Treat nonmoving substrate cracks according to manufacturer's written instructions to prevent cracks from telegraphing (reflecting) through underlayment.
 - 2. Fill all substrate voids, joints, etc. to prevent underlayment from leaking.
- B. Concrete Substrates: Mechanically remove and thoroughly clean, according to manufacturer's written instructions, laitance, glaze, efflorescence, curing compounds, form-release agents, dust, dirt, grease, oil, and other contaminants that might impair underlayment bond.
 - 1. Moisture Testing: Test for MERV, ASTM F 1869-16, or RH, ASTM F2170. Proceed with installation only after substrates do not exceed a maximum moisture-vapor-emission rate of 3 lb of water/1000 sq. ft. (1.36 kg of water/100 sq. m) in 24 hours, or level as required for specified floor covering.
- C. Vapor Barrier: If the moisture level in the concrete substrate exceeds the level required for installation of the specified flooring, treat concrete with an approved moisture vapor barrier product, either Maxxon MVP One or MVP two, as recommended by the underlayment manufacturer. Install other primer or reinforcement product(s) determined necessary for optimum adhesion and performance.
- D. Adhesion Tests: After substrate preparation, test substrate for adhesion with underlayment according to manufacturer's written instructions.

3.3 APPLICATION

- A. General: Mix and apply underlayment components according to manufacturer's written instructions.
 - 1. Close areas to traffic during underlayment application and for time period after application recommended in writing by manufacturer.
 - 2. Coordinate application of components to provide optimum underlayment-to-substrate and intercoat adhesion.
 - 3. At substrate expansion, isolation, and other moving joints, allow joint of same width to continue through underlayment.
- B. Apply vapor retarder product as required, and primer or reinforcement over prepared substrate per manufacturer's recommendations.
- C. Apply underlayment to produce uniform, level surface.
- D. Cure underlayment according to manufacturer's written instructions. Prevent contamination during application and curing processes. Provide mechanical ventilation and heat if required to maintain low relative humidity in strict accordance with manufacturer's recommendations.

- E. Do not install floor coverings over underlayment until after time period recommended in writing by underlayment manufacturer.
- F. Remove and replace underlayment areas that evidence lack of bond with substrate, including areas that emit a "hollow" sound when tapped.

3.4 PROTECTION

- A. Protect underlayment from concentrated and rolling loads for remainder of construction period.

END OF SECTION 035416

SECTION 042000 - UNIT MASONRY

PART 1 - GENERAL

1.1 RELATED DOCUMENTS

- A. Drawings and general provisions of the Contract, including General and Supplementary Conditions and Division 01 Specification Sections, apply to this Section.

1.2 SUMMARY

- A. This Section includes unit masonry assemblies consisting of the following:
 - 1. Decorative concrete masonry units, load bearing and non-load bearing. Includes HI-R-H units with and without rigid insulation unit inserts.
 - 2. Decorative concrete masonry units, integrally colored veneer units.
 - 3. Standard concrete masonry units, load bearing and non-load bearing. Includes HI-R-H units with and without rigid insulation inserts.
 - 4. Mortar and grout.
 - 5. Reinforcing steel.
 - 6. Ties and Anchors.
 - 7. Rigid masonry-cell insulation.
 - 8. Miscellaneous masonry accessories.
- B. Products installed, but not furnished, under this Section include the following:
 - 1. Anchor bolts and embed plates, furnished under Division 05 Sections “Structural Steel Framing” and “Metal Fabrications”.
 - 2. Fire department lock box furnished under Division 08 Section “Door Hardware”.
- C. Related Sections: Section 071900 – Water Repellents applied to unit masonry assemblies.

1.3 DEFINITIONS

- A. Reinforced Masonry: Masonry containing reinforcing steel in grouted cells.

1.4 PERFORMANCE REQUIREMENTS

- A. Provide structural unit masonry that develops indicated net-area compressive strengths (f_m) at 28 days.
- B. Determine net-area compressive strength by unit-strength method.

1.5 SUBMITTALS

- A. Product Data: For each type of product indicated.
- B. Shop Drawings: For the following:
 - 1. Masonry Units: Show sizes, profiles, coursing, and locations of special shapes.
 - 2. Reinforcing Steel: Detail bending and placement of unit masonry reinforcing bars. Comply with American Concrete Institute (ACI) ACI 315, "Details and Detailing of Concrete Reinforcement." Show elevations of reinforced walls.
- C. Samples for Initial Selection: For the following:
 - 1. Colored mortar samples.
- D. Samples for Verification: For each type and color of the following:
 - 1. Concrete masonry units, in the form of full size units. Final verification of CMU colors is subject to approval of full size samples.
 - 2. Pigmented and colored-aggregate mortar. Make Samples using same sand and mortar ingredients to be used on Project. Label Samples to indicate types and amounts of pigments used.
 - 3. Accessories embedded in masonry.
- E. List of Materials Used in Constructing Mockups: List generic product names together with manufacturers, manufacturers' product names, model numbers, lot numbers, batch numbers, source of supply, and other information as required to identify materials used. Include mix proportions for mortar and grout and source of aggregates.
 - 1. Submittal is for information only. Neither receipt of list nor approval of mockup constitutes approval of deviations from the Contract Documents unless such deviations are specifically brought to the attention of Architect and approved in writing.
- F. Material Certificates: Include statements of material properties indicating compliance with requirements including compliance with standards and type designations within standards. Provide for each type and size of the following:
 - 1. Masonry units.
 - a. Include material test reports substantiating compliance with requirements.
 - b. For masonry units used in structural masonry, include data and calculations establishing average net-area compressive strength of units.
 - c. Integral water repellent used in CMUs.
 - 2. Preblended, dry mortar mixes. Include description of type and proportions of ingredients.
 - 3. Grout mixes. Include description of type and proportions of ingredients.
 - 4. Reinforcing bars.
 - 5. Anchors, ties, and metal accessories.
 - 6. Rigid insulation inserts.
- G. Mix Designs: For each type of mortar and grout. Include description of type and proportions of ingredients.

1. Include test reports for mortar mixes required to comply with property specification. Test according to ASTM C 109/C 109M for compressive strength, ASTM C 1506 for water retention, and ASTM C 91 for air content.
 2. Include test reports, per ASTM C 1019 for grout mixes required to comply with compressive strength requirement.
- H. Statement of Compressive Strength of Masonry: For each combination of masonry unit type and mortar type, provide statement of average net-area compressive strength of masonry units, mortar type, and resulting net-area compressive strength of masonry determined according to Tables 1 and 2 in ACI 530.1/ASCE 6/TMS 602.
- I. Cold-Weather Procedures: Detailed description of methods, materials, and equipment to be used to comply with cold-weather requirements.

1.6 QUALITY ASSURANCE

- A. Source Limitations for Masonry Units: Obtain exposed masonry units of a uniform texture and color, or a uniform blend within the ranges accepted for these characteristics, through one source from a single manufacturer for each product required.
- B. Source Limitations for Mortar Materials: Obtain mortar ingredients of a uniform quality, including color for exposed masonry, from a single manufacturer for each cementitious component and from one source or producer for each aggregate.
- C. Preconstruction Testing Service: Owner will engage a qualified independent testing agency to perform preconstruction testing indicated below. Payment for these services will be made by Owner. Retesting of materials that fail to meet specified requirements shall be done at Contractor's expense.
1. Concrete Masonry Unit Tests: For each different concrete masonry unit indicated, units will be tested for strength and absorption per ASTM C 140 and also moisture content/lineal shrinkage. Tests shall be performed at place of manufacture. Only lots tested and found to be in compliance with specified requirements shall be delivered to project site.
 2. Mortar Test (Property Specification): For each mix required, per ASTM C 780.
 3. Grout Test (Compressive Strength): For each mix required, per ASTM C 1019.
 4. Prism Test: For each type of construction required, per ASTM C 1314.
- D. Fire-Resistance Ratings: Where indicated, provide materials and construction identical to those of assemblies with fire-resistance ratings determined per ASTM E 119 by a testing and inspecting agency, by equivalent concrete masonry thickness, or by other means, as acceptable to authorities having jurisdiction.
- E. Sample Panel: Build sample panel to verify selections made under sample submittals and to demonstrate aesthetic effects.
1. Build sample panel including each type and color of decorative unit masonry construction approximately 64 inches long by 48 inches high by full thickness. Install control joint gasket at center of the panel.

2. Clean only one-half of exposed face of panel with masonry cleaner indicated, and clean and seal other half with specified water repellent sealer.
3. Provide a smooth block course entire length at the top of the panel.
4. Protect approved sample panel from the elements with weather-resistant membrane.
5. Approval of sample panel is for color, texture, and blending of masonry units; relationship of mortar and sealant colors to masonry unit colors; tooling of joints; aesthetic qualities of workmanship; and other material and construction qualities specifically approved by Architect in writing.
 - a. Approval of sample panel does not constitute approval of deviations from the Contract Documents contained in sample panel unless such deviations are specifically approved by Architect in writing.
6. Locate sample panel at construction site with south facing orientation at location directed by Architect.
7. Provide (2) individual color samples of mortar as selected by the Architect for review with the sample panel construction.

1.7 DELIVERY, STORAGE, AND HANDLING

- A. Store masonry units on elevated platforms in a dry location. If units are not stored in an enclosed location, cover tops and sides of stacks with waterproof sheeting, securely tied. If units become wet, do not install until they are dry.
- B. Store cementitious materials on elevated platforms, under cover, and in a dry location. Do not use cementitious materials that have become damp.
- C. Store aggregates where grading and other required characteristics can be maintained and contamination avoided.
- D. Deliver preblended, dry mortar mix in moisture-resistant containers designed for lifting and emptying into dispensing silo. Store preblended, dry mortar mix in delivery containers on elevated platforms, under cover, and in a dry location or in a metal dispensing silo with weatherproof cover.
- E. Store masonry accessories, including metal items, to prevent corrosion and accumulation of dirt and oil.

1.8 PROJECT CONDITIONS

- A. Protection of Masonry: During construction, cover tops of walls, projections, and sills with waterproof sheeting at **end of each day's work**. Cover partially completed masonry when construction is not in progress.
 1. Extend cover a minimum of 24 inches (600 mm) down both sides and hold cover securely in place.

- B. Do not apply uniform floor or roof loads for at least 12 hours and concentrated loads for at least 3 days after building masonry walls or columns.
- C. Stain Prevention: Prevent grout, mortar, and soil from staining the face of masonry to be left exposed or painted. Immediately remove grout, mortar, and soil that comes in contact with such masonry.
 - 1. Protect base of walls from rain-splashed mud and from mortar splatter by spreading coverings on ground and over wall surface.
 - 2. Protect sills, ledges, and projections from mortar droppings.
 - 3. Protect surfaces of window and door frames, as well as similar products with painted and integral finishes, from mortar droppings.
 - 4. Turn scaffold boards near the wall on edge at the end of each day to prevent rain from splashing mortar and dirt onto completed masonry.
- D. Cold-Weather Requirements: Do not use frozen materials or materials mixed or coated with ice or frost. Do not build on frozen substrates. Remove and replace unit masonry damaged by frost or by freezing conditions. Comply with cold-weather construction requirements contained in ACI 530.1/ASCE 6/TMS 602.
 - 1. Cold-Weather Cleaning: Use liquid cleaning methods only when air temperature is 40 deg F (4 deg C) and above and will remain so until masonry has dried, but not less than 7 days after completing cleaning.
- E. Hot-Weather Requirements: Comply with hot-weather construction requirements contained in ACI 530.1/ASCE 6/TMS 602.

PART 2 - PRODUCTS

2.1 MANUFACTURERS

- A. In other Part 2 articles where titles below introduce lists, the following requirements apply to product selection:
 - 1. Products: Subject to compliance with requirements, provide one of the products specified.
 - 2. Manufacturers: Subject to compliance with requirements, provide products by one of the manufacturers specified.
- B. Products and/or manufacturers other than those specified are subject to the Architect's approval prior to bidding.

2.2 MASONRY UNITS, GENERAL

- A. Defective Units: Referenced masonry unit standards may allow a certain percentage of units to exceed tolerances and to contain chips, cracks, or other defects exceeding limits stated in the standard. Do not use units where such defects, including dimensions that vary from specified

dimensions by more than stated tolerances, will be exposed in the completed Work or will impair the quality of completed masonry.

2.3 CONCRETE MASONRY UNITS (CMUs)

A. Shapes: Provide shapes indicated and as follows:

1. Provide special shapes for lintels, corners, jambs, sashes, movement joints, headers, bonding, and other special conditions.
2. Provide square-edged units for outside corners at exterior and/or at decorative masonry unless otherwise indicated.
3. Provide square edge units for outside corners at interior locations.

B. Integral Water Repellent: Provide units made with integral water repellent for exposed units.

1. Integral Water Repellent: Liquid polymeric, integral water-repellent admixture that does not reduce flexural bond strength. Units made with integral water repellent, when tested as a wall assembly made with mortar containing integral water-repellent manufacturer's mortar additive according to ASTM E 514, with test period extended to 24 hours, show no visible water or leaks on the back of test specimen.

a. Products:

- 1) Addiment Incorporated; Block Plus W-10.
- 2) Grace Construction Products, a unit of W. R. Grace & Co. - Conn.; Dry-Block.
- 3) Master Builders, Inc.; Rheopel.

C. Concrete Masonry Units: ASTM C 90 load bearing units.

1. Unit Compressive Strength: Provide units with minimum average net-area compressive strength of 2,000 psi, and higher strengths per Structural Notes.
2. Weight Classification: Medium weight.
3. Size (Width): Manufactured to dimensions 3/8 inch less than nominal dimensions.
4. HI-R-H Single Web Blocks: At locations indicated and required.
5. Pattern and Texture: Standard smooth face.
6. Colors: Standard grey, for use at non-exposed and painted locations. See Paragraph D for integrally colored decorative units.
7. Available Products:

a. Basalite Concrete Products, Meridian, Idaho.

8. Maximum Moisture Content: 30 percent as tested prior to delivery to project site.

D. Decorative Concrete Masonry Units: ASTM C 90, load bearing units and non-load bearing veneer units.

1. Unit Compressive Strength: Provide units with minimum average net-area compressive strength of 2,000 psi, and higher strengths per Structural Notes.
2. Weight Classification: Medium weight.

3. Size (Width): Manufactured to dimensions 3/8" less than nominal dimensions.
 4. HI-R-H Single Web Blocks: At locations indicated and required.
 5. Pattern and Texture: As indicated on the Drawings and to include:
 - a. Integrally colored standard smooth face finish, for use at specified accent locations.
 - b. Integrally colored split face finish, for use at specified field locations.
 6. Colors: Decorative CMU colors shall be as follows.
 - a. Color A: Load bearing and veneer units: Basalite Harvest Gold.
 - b. Color B: Load bearing units: Basalite Burgundy.
 - c. Refer to Drawings for locations of color and texture of masonry.
 7. Available Products:
 - a. Basalite Concrete Products, Meridian, Idaho
 8. Maximum Moisture Content: 30 percent as tested prior to delivery to project site.
- E. Insulated CMUs: Install at all exterior load bearing masonry locations. Units shall contain rigid specially shaped, cellular thermal insulation units complying with ASTM C 578, Type "X", designed for installing in cores of masonry units.
1. Specially shaped cellular thermal rigid insulation units shall be provided at nominal 12 inch wide by 8 inch high units at locations indicated on Drawings.
 2. Thermal Resistance (R) per inch of thickness = 5.00
 3. Components: Insulation shall contain no fluorocarbons and no formaldehyde.
 4. Shape: Two-piece, interlocking insert shall overlap at both head and bed joints with edges of adjacent inserts of the same type. Keyway shall be provided for butt welded cross-rods of 16" oc. ladder type horizontal wall reinforcement.
 - a. Products:
 1. Concrete Products Group, LLC; CBIS "Korfil HI-R-H" two-piece inserts for 12" HI-R-H block with single web member.

2.4 MASONRY LINTELS

- A. General: Provide masonry lintels complying with requirements below.
- B. Masonry Lintels: Built-in-place masonry lintels made from lintel and bond beam concrete masonry units with reinforcing bars placed as indicated and filled with coarse grout. Temporarily support built-in-place lintels until cured.

2.5 MORTAR AND GROUT MATERIALS

- A. Portland Cement: ASTM C 150, Type I or II, except Type III may be used for cold-weather construction. Provide natural color or white cement as required to produce mortar color indicated.
- B. Hydrated Lime: ASTM C 207, Type S.
- C. Mortar Pigments: Natural and synthetic iron oxides and chromium oxides, compounded for use in mortar mixes. Use only pigments with a record of satisfactory performance in masonry mortar.
 - 1. Products:
 - a. Bayer Corporation, Industrial Chemicals Div.; Bayferrox Iron Oxide Pigments.
 - b. Davis Colors; True Tone Mortar Colors.
 - c. Solomon Grind-Chem Services, Inc.; SGS Mortar Colors.
- D. Aggregate for Mortar: ASTM C 144.
 - 1. For mortar that is exposed to view, use washed aggregate consisting of natural sand or crushed stone.
 - 2. Colored-Mortar Aggregates: Natural sand or crushed stone of color necessary to produce required mortar color.
- F. Aggregate for Grout: ASTM C 404.
- G. Water-Repellent Admixture: Liquid water-repellent mortar admixture intended for use with concrete masonry units, containing integral water repellent by same manufacturer as CMU units.
 - 1. Available Products:
 - a. Addiment Incorporated; Mortar Tite.
 - b. Grace Construction Products, a unit of W. R. Grace & Co. - Conn.; Dry-Block Mortar Admixture.
 - c. Master Builders, Inc.; Color Cure Mortar Admix or Rheomix Rheopel.
- H. Water: Potable.

2.6 REINFORCEMENT

- A. Uncoated Steel Reinforcing Bars: ASTM A 615/A 615M or ASTM A 996/A 996M, Grade 60 (Grade 420).
 - 1. Use ASTM A 706, Grade 60, weldable reinforcing bars where indicated or required.
- B. Masonry Joint Reinforcement: Hot-dip galvanized carbon steel per ASTM A 951 / A 951M. Side rod and cross rod diameter and spacing per Structural Drawings.

2.7 MISCELLANEOUS ANCHORS AND TIES

- A. Unit Type Inserts in Concrete: Cast-iron or malleable-iron wedge-type inserts.
- B. Anchor Bolts: Headed or L-shaped steel bolts complying with ASTM A 307, Grade A (ASTM F 568M, Property Class 4.6); with ASTM A 563 (ASTM A 563M) hex nuts and, where indicated, flat washers; hot-dip galvanized to comply with ASTM A 153/A 153M, Class C; of dimensions indicated.
- C. Post-installed Anchors: Provide chemical or torque-controlled expansion anchors, with capability to sustain, without failure, a load equal to six times the load imposed when installed in solid or grouted unit masonry and equal to four times the load imposed when installed in concrete, as determined by testing per ASTM E 488 conducted by a qualified independent testing agency.
 - 1. Corrosion Protection: Carbon-steel components zinc plated to comply with ASTM B 633, Class Fe/Zn 5 (5 microns) for Class SC 1 service condition (mild).
- D. Veneer Ties: Equal to Hohmann and Barnard Inc. Thermal 2-seal, hot-dipped galvanized anchor system with 3/16" hot dipped galvanized steel 2-Seal Byna-Lok wire ties for veneer attachment. Refer to Structural Notes for additional requirements.

2.8 MISCELLANEOUS MASONRY ACCESSORIES

- A. Compressible Filler: Premolded filler strips complying with ASTM D 1056, Grade 2A1; compressible up to 35 percent; of width and thickness indicated; formulated from neoprene, urethane, or PVC.
- B. Preformed Control-Joint Gaskets: Made from styrene-butadiene-rubber compound, complying with ASTM D 2000, Designation M2AA-805 or PVC, complying with ASTM D 2287, Type PVC-65406 and designed to fit standard sash block and to maintain lateral stability in masonry wall; size and configuration as indicated.
- C. Reinforcing Bar Positioners: Wire units designed to fit into mortar bed joints spanning standard masonry unit cells with loops for holding reinforcing bars in center of cells. Units are formed from 0.142-inch (3.6-mm) steel wire, hot-dip galvanized after fabrication. Provide units with either two loops or four loops as needed for number of bars indicated, at standard blocks only.
 - 1. Products:
 - a. Dayton Superior Corporation, Dur-O-Wal Division; D/A 810, D/A 812 or D/A 817.
 - b. Heckmann Building Products Inc.; No. 376 Rebar Positioner.
 - c. Hohmann & Barnard, Inc.; #RB or #RB-Twin Rebar Positioner.
 - d. Wire-Bond; O-Ring or Double O-Ring Rebar Positioner.
- D. Bond-Breaker Strips: Asphalt-saturated, organic roofing felt complying with ASTM D 226, Type I (No. 15 asphalt felt).

- E. Weep/Cavity Vent Products: Use the following unless otherwise indicated
1. Wicking Material: Absorbent rope, made from UV-resistant synthetic fiber, 1/4 to 3/8-inch (6 to 10 mm) in diameter, in length required to produce two (2) inch (50-mm) exposure on exterior and eighteen (18) inches (450 mm) in cavity. Use only for weeps.
 2. Mesh Weep/Vent: Free-draining mesh; made from polyethylene strands, full height and width of head joint and depth 1/8-inch (3 mm) less than depth of outer wythe; in color selected from manufacturer's standard.
 - a. Manufacturers: Subject to compliance with requirements, provide products by one of the following:
 - 1) Advanced Building Products Inc.
 - 2) CavClear/Archovations, Inc.
 - 3) Keene Building Products.
 - 4) Mortar Net Solutions.
- F. Cavity Drainage Material: Free-draining mesh, made from polymer strands that will not degrade within the wall cavity.
3. Manufacturers: Subject to compliance with requirements, provide products by one of the following:
 - a. Advanced Building Products Inc.
 - b. CavClear/Archovations, Inc.
 - c. Heckmann Building Products, Inc.
 - d. Hohmann & Barnard, Inc.
 - e. Mortar Net Solutions.
 - f. Wire-Bond.
 4. Configuration: Provide the following:
 - a. Sheets or strips, full depth of cavity x 8 inches high, unless shown otherwise.

2.9 MASONRY CLEANERS

- A. Proprietary Cleaner: Manufacturer's standard-strength cleaner designed for removing mortar/grout stains, efflorescence, and other new construction stains from new masonry without discoloring or damaging masonry surfaces. Use product expressly approved for intended use by cleaner manufacturer and manufacturer of masonry units being cleaned.
1. Manufacturers:
 - a. Diedrich Technologies, Inc.
 - b. EaCo Chem, Inc.
 - c. ProSoCo, Inc.

2.10 MORTAR AND GROUT MIXES

- A. General: Do not use admixtures, including pigments, air-entraining agents, accelerators, retarders, water-repellent agents, antifreeze compounds, or other admixtures, unless otherwise indicated.
 - 1. Do not use calcium chloride in mortar or grout.
 - 5. Limit cementitious materials in mortar to portland cement and lime.
- B. Preblended, Dry Mortar Mix: Furnish dry mortar ingredients in form of a preblended mix. Measure quantities by weight to ensure accurate proportions, and thoroughly blend ingredients before delivering to Project site.
- C. Mortar for Unit Masonry: Comply with ASTM C 270 and Table 2103.7(1) of the International Building Code, 2018 Edition, Proportion Specification. Provide the following types of mortar for applications stated unless another type is indicated or needed to provide required compressive strength of masonry.
 - 1. For masonry below grade or in contact with earth, use Type M.
 - 2. For reinforced masonry, use Type S.
 - 3. For masonry veneer, use Type N.
 - 4. Minimum mortar compressive strength shall be 1,800 lbs. / sq. m. at 28 days and higher strengths per Structural Notes.
- D. Pigmented Mortar: At all integrally colored unit masonry, use colored cement product or select and proportion pigments with other ingredients to produce color required. Do not add pigments to colored cement products.
 - 1. Pigments shall not exceed 10 percent of portland cement by weight.
 - 2. Mix to match samples approved by Architect.
 - 3. Mortar color shall match adjacent unit masonry color; three colors are required.
- E. Grout for Unit Masonry: Comply with ASTM C 476 and Table 2103.10 of the International Building Code, 2018 Edition.
 - 1. Use coarse grout proportioned as per Table 2103.10 in the International Building Code, 2015 Edition.
 - 2. Provide grout with a slump of 8 to 11 inches (200 to 280 mm) as measured according to ASTM C 143/C 143M.
 - 3. Minimum grout compressive strength shall be 2,000 lbs. / sq. m. at 28 days and higher strengths per Structural Notes.

PART 3 - EXECUTION

3.1 EXAMINATION

- A. Examine conditions, with Installer present, for compliance with requirements for installation tolerances and other conditions affecting performance of work.

1. For the record, prepare written report, endorsed by Installer, listing conditions detrimental to performance of work.
 2. Verify that foundations are within tolerances specified.
 3. Verify that reinforcing dowels are properly placed.
- B. Before installation, examine rough-in and built-in construction for piping systems to verify actual locations of piping connections.
- C. Proceed with installation only after unsatisfactory conditions have been corrected.

3.2 INSTALLATION, GENERAL

- A. Thickness: Build single-wythe walls to actual widths of masonry units, using units of widths indicated.
- B. Build chases and recesses to accommodate items specified in this and other Sections.
- C. Leave openings for equipment to be installed before completing masonry. After installing equipment, complete masonry to match the construction immediately adjacent to opening.
- D. Use full-size units without cutting if possible. If cutting is required to provide a continuous pattern or to fit adjoining construction, cut units with motor-driven saws; provide clean, sharp, unchipped edges. Allow units to dry before laying unless wetting of units is specified. Install cut units with cut surfaces and, where possible, cut edges concealed.
- E. Select and arrange units for exposed unit masonry to produce a uniform blend of colors and textures.
1. Mix units from several pallets or cubes as they are placed.
- F. Comply with construction tolerances in ACI 530.1/ASCE 6/TMS 602 and with the following:
1. For conspicuous vertical lines, such as external corners, door jambs, reveals, and expansion and control joints, do not vary from plumb by more than 1/8 inch in 10 feet (3 mm in 3 m), 1/4 inch in 20 feet (6 mm in 6 m), or 1/2 inch (12 mm) maximum.
 2. For vertical alignment of exposed head joints, do not vary from plumb by more than 1/4 inch in 10 feet (6 mm in 3 m), or 1/2 inch (12 mm) maximum.
 3. For conspicuous horizontal lines, such as lintels, sills, parapets, and reveals, do not vary from level by more than 1/8 inch in 10 feet (3 mm in 3 m), 1/4 inch in 20 feet (6 mm in 6 m), or 1/2 inch (12 mm) maximum.
 4. For exposed bed joints, do not vary from thickness indicated by more than plus or minus 1/8 inch (3 mm), with a maximum thickness limited to 1/2 inch (12 mm). Do not vary from bed-joint thickness of adjacent courses by more than 1/8 inch (3 mm).
 5. For exposed head joints, do not vary from thickness indicated by more than plus or minus 1/8 inch (3 mm). Do not vary from adjacent bed-joint and head-joint thicknesses by more than 1/8 inch (3 mm).
 6. For faces of adjacent exposed masonry units, do not vary from flush alignment by more than 1/16 inch (1.5 mm) except due to warpage of masonry units within tolerances specified for warpage of units.

3.3 LAYING MASONRY WALLS

- A. Lay out walls in advance for accurate spacing of surface bond patterns with uniform joint thicknesses and for accurate location of openings, movement-type joints, returns, and offsets. Avoid using less-than-half-size units, particularly at corners, jambs, and, where possible, at other locations.
- B. Bond Pattern for Exposed Masonry: Lay exposed masonry in bond patterns indicated on Drawings; do not use units with less than nominal 4-inch (100-mm) horizontal face dimensions at corners or jambs.
- C. Lay concealed masonry with all units in a wythe in running bond or bonded by lapping not less than 4-inches (100-mm). Bond and interlock each course of each wythe at corners. Do not use units with less than nominal 4-inch (100-mm) horizontal face dimensions at corners or jambs.
- D. Attach veneer anchors to structural masonry walls at 16" o.c. horizontally and not to exceed 16" o.c. vertically. Slush space between CMU wall and veneer with mortar as required at ties for spacing and support.
- E. Stopping and Resuming Work: Stop work by racking back units in each course from those in course below; do not tooth. When resuming work, clean masonry surfaces that are to receive mortar, remove loose masonry units and mortar, and wet brick if required before laying fresh masonry.
- F. Built-in Work: As construction progresses, build in items specified in this and other Sections. Fill in solidly with masonry around built-in items.
- G. Fill space between steel frames and masonry solidly with mortar, unless otherwise indicated.
- H. Where built-in items are to be embedded in cores of hollow masonry units, place a layer of metal lath, wire mesh, or plastic mesh in the joint below and rod mortar or grout into core.
- I. Fill cores in hollow concrete masonry units with grout 24 inches (600 mm) under bearing plates, beams, lintels, posts, and similar items, unless otherwise indicated.
- J. Conduit shall not be permitted in reinforced CMU cores, bond beams, or lintels except as approved by Architect for specific locations.
- K. Where exterior building components (i.e; lights, roofing termination and flashing, roof connections, etc.) occur at split masonry locations those blocks shall be substituted with smooth faced blocks of the same color and size to allow for a proper, watertight and structural connection point. A Pre-Installation Conference shall be required prior to installation to determine all smooth block conditions in split-faced locations with the Architect.

3.4 MORTAR BEDDING AND JOINTING

- A. Lay hollow concrete masonry units as follows:
 - 1. With face shells fully bedded in mortar and with head joints of depth equal to bed joints.
 - 2. With webs fully bedded in mortar in all courses of piers, columns, and pilasters.

3. With webs fully bedded in mortar in grouted masonry, including starting course on footings.
4. With entire units, including areas under cells, fully bedded in mortar at starting course on walls and slabs where cells are not grouted.

- B. Lay solid masonry units with completely filled bed and head joints; butter ends with sufficient mortar to fill head joints and shove into place. Do not deeply furrow bed joints or slush head joints.
- C. Tool exposed joints slightly concave when thumbprint hard, using a jointer larger than joint thickness, unless otherwise indicated. Refer to the Drawings for locations of any special joint tooling.

3.5 MASONRY-CELL INSULATION

- A. Install molded-polystyrene insulation units into masonry unit cells before laying units.
- B. Install molded-polystyrene insulation units in all exterior walls adjacent to interior space.

3.6 CONTROL AND EXPANSION JOINTS

- A. General: Install control and expansion joint materials in unit masonry as masonry progresses. Do not allow materials to span control and expansion joints without provision to allow for in-plane wall or partition movement.
- B. Form control joints in concrete masonry as follows:
 1. Install preformed control-joint gaskets designed to fit standard sash block.
 2. Locate control joints as shown on the Drawings.

3.7 LINTELS

- A. Provide masonry lintels where shown and where openings are more than 16 inches wide and shown without structural steel or other supporting lintels.
- B. Provide minimum bearing of 24 inches (200 mm) at each jamb, unless otherwise indicated.

3.8 REINFORCED UNIT MASONRY INSTALLATION

- A. Temporary Formwork and Shores: Construct formwork and shores as needed to support reinforced masonry elements during construction.
 1. Construct formwork to provide shape, line, and dimensions of completed masonry as indicated. Make forms sufficiently tight to prevent leakage of mortar and grout. Brace, tie, and support forms to maintain position and shape during construction and curing of reinforced masonry.
 2. Do not remove forms and shores until reinforced masonry members have hardened sufficiently to carry their own weight and other temporary loads that may be placed on them during construction.

3.9 PLACING REINFORCEMENT

- A. General: Clean reinforcement of loose rust, mill scale, earth, ice or other materials which will reduce bond to mortar or grout. Do not use reinforcement bars with kinks or bends not shown on drawings or final shop drawings, or bars with reduced cross-section due to excessive rusting or other causes.
- B. Position reinforcement accurately at the spacing indicated. Support and secure vertical bars against displacement. Horizontal reinforcement may be placed as the masonry work progresses. Where vertical bars are shown in close proximity, provide a clear distance between bars of not less than the nominal bar diameter or 1" (whichever is greater.)
- C. For columns, piers and pilasters, provide a clear distance between vertical bars as indicated, but not less than 1 1/2 times the nominal bar diameter or 1 1/2", whichever is greater. Provide lateral ties as indicated.
- D. Provide lapped splices, unless otherwise indicated. In splicing vertical bars or attaching to dowels, lap ends, place in contact and wire tie. Offset splices in bond beams with multiple bars.
 - 1. Provide not less than minimum lap indicated, or if not indicated, 40 bar diameters.
- E. Place vertical reinforcement prior to laying of masonry units. Extend above elevation of maximum pour height as required for splicing. Support in position at top and bottom and at vertical intervals not exceeding 4 ft. Wire tie all vertical reinforcement splices and all vertical/horizontal reinforcement intersections.
 - 1. As an alternative to placing and tying of vertical reinforcement prior to laying of masonry units, use wire positioning devices placed in masonry cores during laying of masonry units and sections of reinforcing bars may be placed prior to grouting of cores and centered by hand during grouting.
- F. Place horizontal bond beam reinforcement and horizontal joint reinforcement as the masonry units are laid. Wire tie all horizontal reinforcement splices.
- G. Do not allow conduit, piping, switch or outlet boxes, etc. in reinforced grouted cores, bond beams, or lintels unless approved by Architect for specific locations.
- H. Conform to all requirements of Chapter 21, International Building Code, 2018 Edition.

3.10 GROUTING

- A. Grouting Technique: Use low-lift-grouting techniques subject to requirements which follow:
- B. Provide minimum clear dimension of 2" and clear area of 8 sq. in. in vertical cores to be grouted.
- C. Place vertical reinforcement prior to laying of masonry units. Extend above elevation of maximum pour height as required for splicing. Support in position at vertical intervals not exceeding 4 ft.
- D. Lay masonry units to maximum pour height. Do not exceed 5'-4" height.

- E. Pour grout using chute or container with spout. Rod or vibrate grout during placing. Place grout continuously; do not interrupt pouring of grout for more than one hour. Terminate grout pours 1 1/2" below top course of pour, except at tops of walls. Where bond beams occur, stop grout pour 1/2" below top of masonry, except at tops of walls.
- F. Bond Beams: Place horizontal beam reinforcement in bond beams; lap at corners and intersections as shown. Place grout in bond beam course before installing masonry above bond beam.
- G. Place horizontal bond beam and lintel reinforcement as the masonry units are laid.
- H. Embed lateral tie reinforcement in mortar joints where indicated. Place as masonry units are laid, at spacing shown.
- I. Preparation of Grout Spaces: Prior to grouting, inspect and clean grout spaces. Remove dust, dirt, mortar droppings, loose pieces of masonry and other foreign materials from grout spaces. Clean reinforcement and adjust to proper position. Clean top surface of structural members supporting masonry to ensure bond. After final cleaning and inspection, cleanout holes and brace closures to resist grout pressures.
- J. Do not place grout until entire height of masonry to be grouted has attained sufficient strength to resist displacement of masonry units and breaking of mortar bond. Install shores and bracing, if required, before starting grouting operations.
- K. Limit grout pours to sections which can be completed in one working day with not more than one-hour interruption of pouring operation. Place grout in lifts which do not exceed 5'. Rod or vibrate each grout lift during pouring operation.
- L. Place grout in lintels or beams over openings in one continuous pour.
- M. Conform to all requirements of International Building Code, 2018 Edition.

3.11 FLASHING, WEEP HOLES, CAVITY DRAINAGE, AND VENTS

- A. General: Install embedded flashing and weep holes in masonry at shelf angles, lintels, ledges, other obstructions to downward flow of water in wall, and where indicated. Install flashing as follows unless otherwise indicated:
 - 1. Prepare masonry surfaces so they are smooth and free from projections that could puncture flashing. Where flashing is within mortar joint, place through-wall flashing on sloping bed of mortar and cover with mortar. Before covering with mortar, seal penetrations in flashing with adhesive, sealant, or tape as recommended by flashing manufacturer.
 - 2. At masonry-veneer walls, extended flashing through veneer, across air space behind veneer, and up face of sheathing at least 8 inches (200 mm); with upper edge tucked under building paper or building wrap, lapping at least 4 inches (100 mm).
- B. Install reglets and nailers for flashing and other related construction where they are shown to be built into masonry.

- C. Inspectors: Owner will engage qualified independent inspectors to perform inspections and prepare reports. Allow inspectors access to scaffolding and work areas, as needed to perform inspections.
 - 1. Place grout only after inspectors have verified compliance of grout spaces and grades, sizes, and locations of reinforcement.
- D. Testing Agency: Owner will engage a qualified independent testing and inspecting agency to perform field tests and inspections indicated below and prepare test reports:
 - 1. Payment for these services will be made by Owner.
 - 2. Retesting of materials failing to comply with specified requirements shall be done at Contractor's expense.
- E. Concrete Masonry Unit Test: For each type of unit provided, per ASTM C 140.
- F. Mortar Test (Property Specification): For each mix provided, per ASTM C 780. Test mortar for mortar air content and compressive strength.
- G. Grout Test (Compressive Strength): For each mix provided, per ASTM C 1019.
- H. Prism Test: For each type of construction provided, per ASTM C 1314 at 7 days and at 28 days.
 - 1. Prepare one set of prisms for testing at 7 days and one set for testing at 28 days for each type/color/texture of masonry.
- I. Evaluation of Quality Control Tests: Masonry will be considered satisfactory if results from construction quality control tests comply with minimum requirements indicated.
- J. Special Inspections required by the International Building Code will be performed by an inspection agency engaged by the Owner and paid directly by the Owner. The Contractor shall fully and completely cooperate with the inspection agency to allow such special inspections to be properly done. See Structural Notes on Drawings.
- K. Moisture Content Lineal Shrinkage Test: For masonry units prior to delivery to the site.

3.12 REPAIRING, POINTING, AND CLEANING

- A. Remove and replace masonry units that are loose, chipped, broken, stained, or otherwise damaged or that do not match adjoining units. Install new units to match adjoining units; install in fresh mortar, pointed to eliminate evidence of replacement.
- B. Pointing: During the tooling of joints, enlarge voids and holes, except weep holes, and completely fill with mortar. Point up joints, including corners, openings, and adjacent construction, to provide a neat, uniform appearance. Prepare joints for sealant application, where indicated.
- C. In-Progress Cleaning: Clean unit masonry as work progresses by dry brushing to remove mortar fins and smears before tooling joints.

- D. Final Cleaning: After mortar is thoroughly set and cured, clean exposed masonry as follows:
1. Remove large mortar particles by hand with wooden paddles and nonmetallic scrape hoes or chisels.
 2. Test cleaning methods on sample wall panel; leave one-half of panel uncleaned for comparison purposes. Obtain Architect's approval of sample cleaning before proceeding with cleaning of masonry.
 3. Protect adjacent surfaces from contact with cleaner by covering them with liquid strippable masking agent or polyethylene film and waterproof masking tape.
 4. Wet wall surfaces with water before applying cleaners; remove cleaners promptly by rinsing surfaces thoroughly with clear water.
 5. Clean masonry with a proprietary acidic cleaner recommended and/or approved by CMU manufacturer and applied according to product manufacturer's written instructions.
 6. Clean concrete masonry by cleaning method indicated in National Concrete Masonry Association (NCMA) TEK 8-2A applicable to type of stain on exposed surfaces.

3.13 MASONRY WASTE DISPOSAL

- A. Salvageable Materials: Unless otherwise indicated, excess masonry materials are Contractor's property. At completion of unit masonry work, remove from Project site.
- B. Masonry Waste: Remove masonry waste and legally dispose of off Owner's property.

END OF SECTION 042000

SECTION 051200 - STRUCTURAL STEEL FRAMING

PART 1 - GENERAL

1.1 RELATED DOCUMENTS

- A. Drawings and general provisions of the Contract, including General and Supplementary Conditions and Division 01 Specification Sections, apply to this Section.

1.2 SUMMARY

- A. This Section includes the following:
 - 1. Structural steel columns, beams, and miscellaneous members.
 - 2. Grout.

1.3 DEFINITIONS

- A. Structural Steel: Elements of structural-steel frame, as classified by American Institute of Steel Construction (AISC) "Code of Standard Practice for Steel Buildings and Bridges," that support design loads.

1.4 SUBMITTALS

- A. Product Data: For each type of product indicated.
- B. Shop Drawings: Show fabrication of structural-steel components.
 - 1. Include details of cuts, connections, splices, camber, holes, and other pertinent data.
 - 2. Include embedment drawings.
 - 3. Indicate welds by standard AWS symbols, distinguishing between shop and field welds, and show size, length, and type of each weld.
 - 4. Indicate type, size, and length of bolts, distinguishing between shop and field bolts. Identify pretensioned and slip-critical high-strength bolted connections.
- C. Welding certificates for informational purposes only.

1.5 QUALITY ASSURANCE

- A. Welding: Qualify procedures and personnel according to American Welding Society (AWS) AWS D1.1, "Structural Welding Code--Steel."
- B. Comply with applicable provisions of the following specifications and documents, as applicable:
 - 1. AISC's "Code of Standard Practice for Steel Buildings and Bridges."

- a. Paragraph 4.2.1 of the above code is hereby modified by deletion of the following sentence:

“This approval constitutes the Owner’s acceptance of all responsibility for the design adequacy of any detail configuration of connections developed by the fabricator as a part of his preparation of these shop drawings.”

2. AISC's "Seismic Provisions for Structural Steel Buildings" and "Supplement No. 2."
 3. AISC's "Specification for the Design of Steel Hollow Structural Sections."
 4. Research Council on Structural Connectors "Specification for Structural Joints Using ASTM A 325 or A 490 Bolts."
- C. Special Inspection: The Owner will engage an inspection agency to provide special inspections as may be required by the 2018 International Building Code. Costs for such services will be paid directly to the inspection agency by the Owner.

1.6 DELIVERY, STORAGE, AND HANDLING

- A. Store materials to permit easy access for inspection and identification. Keep steel members off ground and spaced by using pallets, dunnage, or other supports and spacers. Protect steel members and packaged materials from erosion and deterioration.
 1. Store fasteners in a protected place. Clean and relubricate bolts and nuts that become dry or rusty before use.
 2. Do not store materials on structure in a manner that might cause distortion, damage, or overload to members or supporting structures. Repair or replace damaged materials or structures as directed.

1.7 COORDINATION

- A. Furnish anchorage items to be embedded in or attached to other construction without delaying the Work. Provide setting diagrams, sheet metal templates, instructions, and directions for installation.

PART 2 - PRODUCTS

2.1 STRUCTURAL-STEEL MATERIALS

- A. W-Shapes: ASTM A 992/A 992M, Grade 50.
- B. Other Rolled Shapes: ASTM A 36/A 36M, Grade 36 unless otherwise indicated.
- C. Plate and Bar: ASTM A 36/A 36M, Grade 36 unless otherwise indicated.
- D. Cold-Formed Hollow Structural Sections: ASTM A 500, Grade B, structural tubing. See Structural Notes.
- E. Steel Pipe: ASTM A 53/A 53M, Type E or S, Grade B unless otherwise indicated.

1. Weight Class: As indicated.
2. Finish: Black, except where indicated to be galvanized.

F. Welding Electrodes: Comply with AWS requirements and structural drawings.

2.2 BOLTS, CONNECTORS, AND ANCHORS

A. High-Strength Bolts, Nuts, and Washers: ASTM A 325 (ASTM A 325M) or ASTM A 490 (ASTM A 490M), Type 1, heavy hex steel structural bolts; ASTM A 563 (ASTM A 563M) heavy hex carbon-steel nuts; and ASTM F 436 (ASTM F 436M) hardened carbon-steel washers, unless noted otherwise.

1. Finish: Mechanically deposited zinc coating, ASTM B 695, Class 50.
2. Direct-Tension Indicators: ASTM F 959, Type 325 (ASTM F 959M, Type 8.8,) compressible-washer type.

a. Finish: Mechanically deposited zinc coating, ASTM B 695, Class 50.

B. Shear Connectors: ASTM A 108, Grades 1015 through 1020, headed-stud type, cold-finished carbon steel; AWS D1.1, Type B.

C. Unheaded Anchor Rods: ASTM F 1554, Grade 36 unless otherwise indicated.

1. Configuration: As indicated.
2. Nuts: ASTM A 563 (ASTM A 563M) heavy hex carbon steel.
3. Plate Washers: ASTM A 36/A 36M carbon steel.
4. Washers: ASTM F 436 (ASTM F 436M) hardened carbon steel.
5. Finish: Hot-dip zinc coating, ASTM A 153/A 153M, Class C.

D. Headed Anchor Rods: ASTM F 1554, Grade 36 unless otherwise indicated.

1. Nuts: ASTM A 563 (ASTM A 563M) heavy hex carbon steel.
2. Plate Washers: ASTM A 36/A 36M carbon steel.
3. Washers: ASTM F 436 (ASTM F 436M) hardened carbon steel.
4. Finish: Hot-dip zinc coating, ASTM A 153/A 153M, Class C.

E. Threaded Rods: ASTM A 36/A 36M unless otherwise indicated.

1. Nuts: ASTM A 563 (ASTM A 563M) heavy hex carbon steel.
2. Washers: ASTM A 36/A 36M carbon steel.
3. Finish: Hot-dip zinc coating, ASTM A 153/A 153M, Class C.

F. Eye Bolts and Nuts: ASTM A 108, Grade 1030, cold-finished carbon steel.

G. Sleeve Nuts: ASTM A 108, Grade 1018, cold-finished carbon steel.

2.3 PRIMER

A. Primer: Fabricator's standard lead- and chromate-free, nonasphaltic, rust-inhibiting alkyd primer.

2.4 GROUT

- A. Nonmetallic, Shrinkage-Resistant Grout: ASTM C 1107, factory-packaged, nonmetallic aggregate grout, noncorrosive, nonstaining, mixed with water to consistency suitable for application and a 30-minute working time. BASF "Master flow 928", Sika "SikaGrout - 212", or approved equivalent.

2.5 FABRICATION

- A. Structural Steel: Fabricate and assemble in shop to greatest extent possible. Fabricate according to AISC's "Code of Standard Practice for Steel Buildings and Bridges".
 - 1. Camber structural-steel members where indicated.
 - 2. Mark and match-mark materials for field assembly.
 - 3. Complete structural-steel assemblies, including welding of units, before starting shop-priming operations.
 - 4. Follow tolerance limits for architecturally exposed steel.
- B. Thermal Cutting: Perform thermal cutting by machine to greatest extent possible.
 - 1. Plane thermally cut edges to be welded to comply with requirements in AWS D1.1.
- C. Bolt Holes: Cut, drill, or punch standard bolt holes perpendicular to metal surfaces.
- D. Finishing: Accurately finish ends of columns and other members transmitting bearing loads.
- E. Cleaning: Clean and prepare steel surfaces that are to remain unpainted according to the Society for Protective Coating (SSPC) SSPC-SP 3, "Power Tool Cleaning."
- F. Shear Connectors: Prepare steel surfaces as recommended by manufacturer of shear connectors. Use automatic end welding of headed-stud shear connectors according to AWS D1.1 and manufacturer's written instructions.
- G. Holes: Provide holes required for securing other work to structural steel and for passage of other work through steel framing members.
 - 1. Cut, drill, or punch holes perpendicular to steel surfaces. Do not thermally cut bolt holes or enlarge holes by burning.
 - 2. Base-Plate Holes: Cut, drill, or punch holes perpendicular to steel surfaces.
 - 3. Weld threaded nuts to framing and other specialty items indicated to receive other work.

2.6 SHOP CONNECTIONS

- A. High-Strength Bolts: Shop install high-strength bolts according to RCSC's "Specification for Structural Joints Using ASTM A 325 or A 490 Bolts" for type of bolt and type of joint indicated.
- B. Weld Connections: Comply with AWS D1.1 for welding procedure specifications, tolerances, appearance, and quality of welds and for methods used in correcting welding work.
 - 1. Remove backing bars or runoff tabs, back gouge, and grind steel smooth as indicated.

2. Assemble and weld built-up sections by methods that will maintain true alignment of axes without exceeding tolerances of AISC's "Code of Standard Practice for Steel Buildings and Bridges" for mill material.
3. Verify that weld sizes, fabrication sequence, and equipment used for architecturally exposed structural steel will limit distortions to allowable tolerances

2.7 SHOP PRIMING

- A. Shop prime steel surfaces except the following:
 1. Surfaces embedded in concrete or mortar. Extend priming of partially embedded members to a depth of 2 inches (50 mm).
 2. Surfaces to be field welded.
 3. Surfaces to be high-strength bolted with slip-critical connections.
 4. Surfaces to receive sprayed fire-resistive materials.
- B. Surface Preparation: Clean surfaces to be painted. Remove loose rust and mill scale and spatter, slag, or flux deposits. Prepare surfaces according to the following specifications and standards:
 1. SSPC-SP 3, "Power Tool Cleaning."
- C. Priming: Immediately after surface preparation, apply primer according to manufacturer's written instructions and at rate recommended by SSPC to provide a dry film thickness of not less than 1.5 mils (0.038 mm). Use priming methods that result in full coverage of joints, corners, edges, and exposed surfaces.
 1. Stripe paint corners, crevices, bolts, welds, and sharp edges.
 2. Apply two coats of shop paint to inaccessible surfaces after assembly or erection. Change color of second coat to distinguish it from first.

2.8 SOURCE QUALITY CONTROL

- A. Owner will engage an independent testing and inspecting agency to perform shop tests and inspections and prepare test reports, if and as required
 1. Provide testing agency with access to places where structural-steel work is being fabricated or produced to perform tests and inspections.
- B. Correct deficiencies in Work that test reports and inspections indicate does not comply with the Contract Documents.
- C. Bolted Connections: Shop-bolted connections will be tested and inspected according to RCSC's "Specification for Structural Joints Using ASTM A 325 or A 490 Bolts."
- D. Welded Connections: In addition to visual inspection, shop-welded connections will be tested and inspected according to AWS D1.1 and the following inspection procedures, at testing agency's option:
 1. Liquid Penetrant Inspection: ASTM E 165.

2. Magnetic Particle Inspection: ASTM E 709; performed on root pass and on finished weld. Cracks or zones of incomplete fusion or penetration will not be accepted.
 3. Ultrasonic Inspection: ASTM E 164.
 4. Radiographic Inspection: ASTM E 94.
- E. All complete joint penetration (CJP) and partial joint penetration (PJP) welds to be inspected by one of the following procedures:
1. Ultrasonic Inspection: ASTM E 164.
 2. Radiographic Inspection: ASTM E 94.
- F. In addition to visual inspection, shop-welded shear connectors will be tested and inspected according to requirements in AWS D1.1 for stud welding and as follows:
1. Bend tests will be performed if visual inspections reveal either a less-than- continuous 360-degree flash or welding repairs to any shear connector.
 2. Tests will be conducted on additional shear connectors if weld fracture occurs on shear connectors already tested, according to requirements in AWS D1.1.

PART 3 - EXECUTION

3.1 EXAMINATION

- A. Verify elevations of concrete- and masonry-bearing surfaces and locations of anchor rods, bearing plates, and other embedments, with steel erector present, for compliance with requirements.
- B. Proceed with installation only after unsatisfactory conditions have been corrected.

3.2 PREPARATION

- A. Provide temporary shores, guys, braces, and other supports during erection to keep structural steel secure, plumb, and in alignment against temporary construction loads and loads equal in intensity to design loads. Remove temporary supports when permanent structural steel, connections, and bracing are in place, unless otherwise indicated.
 1. Do not remove temporary shoring supporting composite deck construction until cast-in-place concrete has attained its design compressive strength.

3.3 ERECTION

- A. Set structural steel accurately in locations and to elevations indicated and according to AISC's "Code of Standard Practice for Steel Buildings and Bridges".
- B. Base and Bearing Plates: Clean concrete- and masonry-bearing surfaces of bond-reducing materials, and roughen surfaces prior to setting base and bearing plates. Clean bottom surface of base and bearing plates.

1. Set base and bearing plates for structural members on wedges, shims, or leveling nuts as required and indicated.
 2. Weld plate washers to top of base plate as indicated.
 3. Snug-tighten nuts on anchor bolts or rods after supported members have been positioned and plumbed. Do not remove wedges or shims but, if protruding, cut off flush with edge of base or bearing plate before packing with grout.
 4. Promptly pack grout solidly between bearing surfaces and base or bearing plates so no voids remain. Neatly finish exposed surfaces; protect grout and allow to cure. Comply with manufacturer's written installation instructions for shrinkage-resistant grouts.
- C. Maintain erection tolerances of structural steel within AISC's "Code of Standard Practice for Steel Buildings and Bridges."
- D. Align and adjust various members forming part of complete frame or structure before permanently fastening. Before assembly, clean bearing surfaces and other surfaces that will be in permanent contact with members. Perform necessary adjustments to compensate for discrepancies in elevations and alignment.
1. Level and plumb individual members of structure.
 2. Make allowances for difference between temperature at time of erection and mean temperature when structure is completed and in service.
- E. Splice members only where indicated.
- F. Remove erection bolts on welded, architecturally exposed structural steel; fill holes with plug welds; and grind smooth at exposed surfaces.
- G. Do not use thermal cutting during erection.
- H. Do not enlarge unfair holes in members by burning or using drift pins. Ream holes that must be enlarged to admit bolts with structural engineers approval.
- I. Shear Connectors: Prepare steel surfaces as recommended by manufacturer of shear connectors. Use automatic end welding of headed-stud shear connectors according to AWS D1.1 and manufacturer's written instructions.

3.4 FIELD CONNECTIONS

- A. High-Strength Bolts: Install high-strength bolts according to RCSC's "Specification for Structural Joints Using ASTM A 325 or A 490 Bolts" for type of bolt and type of joint indicated.
- B. Weld Connections: Comply with AWS D1.1 for welding procedure specifications, tolerances, appearance, and quality of welds and for methods used in correcting welding work.
1. Comply with AISC's "Code of Standard Practice for Steel Buildings and Bridges" for bearing, adequacy of temporary connections, alignment, and removal of paint on surfaces adjacent to field welds.
 2. Remove backing bars or runoff tabs, back gouge, and grind steel smooth as indicated.

3. Assemble and weld built-up sections by methods that will maintain true alignment of axes without exceeding tolerances of AISC's "Code of Standard Practice for Steel Buildings and Bridges" for mill material.
4. Verify that weld sizes, fabrication sequence, and equipment used for architecturally exposed structural steel will limit distortions to allowable tolerances.

3.5 FIELD QUALITY CONTROL

- A. Testing Agency: Owner will engage a qualified independent testing and inspecting agency to inspect field welds and high-strength bolted connections.
- B. Bolted Connections: Shop-bolted connections will be tested and inspected according to RCSC's "Specification for Structural Joints Using ASTM A 325 or A 490 Bolts."
- C. Welded Connections: Field welds will be visually inspected according to AWS D1.1.
 1. In addition to visual inspection, field welds will be tested according to AWS D1.1 and the following inspection procedures, at testing agency's option:
 - a. Liquid Penetrant Inspection: ASTM E 165.
 - b. Magnetic Particle Inspection: ASTM E 709; performed on root pass and on finished weld. Cracks or zones of incomplete fusion or penetration will not be accepted.
 - c. Ultrasonic Inspection: ASTM E 164.
 - d. Radiographic Inspection: ASTM E 94.
 2. All complete joint penetration (CJP) and partial joint penetration (PJP) welds to be inspected by one of the following procedures:
 - a. Ultrasonic Inspection: ASTM E 164.
 - b. Radiographic Inspection: ASTM E 94.
- D. In addition to visual inspection, field-welded shear connectors will be tested and inspected according to requirements in AWS D1.1 for stud welding and as follows:
 1. Perform bend tests if visual inspections reveal either a less-than- continuous 360-degree flash or welding repairs to any shear connector.
 2. Conduct tests on additional shear connectors if weld fracture occurs on shear connectors already tested, according to requirements in AWS D1.1.
- E. Correct deficiencies in Work that test reports and inspections indicate does not comply with the Contract Documents.

3.6 REPAIRS AND PROTECTION

- A. Touchup Painting: After installation, promptly clean, prepare, and prime or reprime field connections, rust spots, and abraded surfaces of prime-painted joists and accessories, bearing plates, and abutting structural steel.

1. Clean and prepare surfaces by SSPC-SP 2 hand-tool cleaning or SSPC-SP 3 power-tool cleaning.
2. Apply a compatible primer of same type as shop primer used on adjacent surfaces.

END OF SECTION 051200

THIS PAGE INTENTIONALLY BLANK

SECTION 052100 - STEEL JOIST FRAMING

PART 1 - GENERAL

1.1 RELATED DOCUMENTS

- A. Drawings and general provisions of the Contract, including General and Supplementary Conditions and Division 01 Specification Sections, apply to this Section.

1.2 SUMMARY

- A. This Section includes the following roof joists:

1. LH-Series steel joists.
2. K-Series steel joists.
3. Joist accessories.

1.3 DEFINITIONS

- A. SJI "Specifications": Steel Joist Institute's (SJI) "Standard Specifications, Load Tables and Weight Tables for Steel Joists and Joist Girders."
- B. Special Joists: Steel joists or joist girders requiring modification by manufacturer to support nonuniform, unequal, or special loading conditions that invalidate load tables in SJI's "Specifications."

1.4 PERFORMANCE REQUIREMENTS

- A. Structural Performance: Provide special joists and connections capable of withstanding design loads indicated.
- B. Design special joists to withstand design loads with live load deflections no greater than the following:
 1. Roof Joists: Vertical live load deflection of $L/240$ of the span.

1.5 SUBMITTALS

- A. Product Data: For each type of joist, accessory, and product indicated.
- B. Shop Drawings: Show layout, designation, number, type, location, and spacings of joists. Include joining and anchorage details, bracing, bridging, joist accessories; splice and connection locations and details; and attachments to other construction.
 1. Indicate locations and details of bearing plates to be embedded in other construction.
 2. Comprehensive engineering analysis of special joists signed and sealed by the qualified professional engineer responsible for its preparation.

- C. Welding certificates.
- D. Manufacturer Certificates: Signed by manufacturers certifying that joists comply with requirements.
- E. Mill Certificates: Signed by bolt manufacturers certifying that bolts comply with requirements.
- F. Qualification Data: For manufacturer, professional engineer.
- G. Field quality-control test and inspection reports.
- H. Research/Evaluation Reports: For joists.

1.6 QUALITY ASSURANCE

- A. Manufacturer Qualifications: A manufacturer certified by SJI to manufacture joists complying with applicable standard specifications and load tables of SJI "Specifications."
 - 1. Manufacturer's responsibilities include providing professional engineering services for designing special joists to comply with performance requirements.
- B. SJI Specifications: Comply with standard specifications in SJI's "Specifications" that are applicable to types of joists indicated.
- C. Welding: Qualify procedures and personnel according to American Welding Society (AWS) AWS D1.1/D1.1M, "Structural Welding Code - Steel."

1.7 DELIVERY, STORAGE, AND HANDLING

- A. Deliver, store, and handle joists as recommended in SJI's "Specifications."
- B. Protect joists from corrosion, deformation, and other damage during delivery, storage, and handling.

1.8 SEQUENCING

- A. Deliver steel bearing plates to be built into masonry construction.

PART 2 - PRODUCTS

2.1 MATERIALS

- A. Steel: Comply with SJI's "Specifications" for web and steel-angle chord members.
- B. Steel Bearing Plates: ASTM A 36/A 36M unless otherwise indicated.

- C. Carbon-Steel Bolts and Threaded Fasteners: ASTM A 307, Grade A (ASTM F 568M, Property Class 4.6), carbon-steel, hex-head bolts and threaded fasteners; carbon-steel nuts; and flat, unhardened steel washers.
 - 1. Finish: Plain, uncoated.
- D. High-Strength Bolts, Nuts, and Washers: ASTM A 325 (ASTM A 325M) or ASTM A 490 (ASTM A 490M), Type 1, heavy hex steel structural bolts; ASTM A 563 (ASTM A 563M) heavy hex carbon-steel nuts; and ASTM F 436 (ASTM F 436M) hardened carbon-steel washers.
 - 1. Finish: Mechanically deposited zinc coating, ASTM B 695, Class 50.
- E. Welding Electrodes: Comply with AWS standards and structural drawings.

2.2 PRIMERS

- A. Primer at concealed locations: SSPC-Paint 15, or manufacturer's standard shop primer complying with performance requirements in SSPC-Paint 15.
- B. Primer at exposed locations: Provide shop primer that complies with Division 09 painting Sections.

2.3 DLH-SERIES STEEL JOISTS

- A. Manufacture steel joists of type indicated according to "Standard Specifications for Open Web Steel Joists, K-Series" in SJI's "Specifications," with steel-angle top- and bottom-chord members, underslung ends, and parallel top chord.
 - 1. Joist Types: LH Series and K Series steel joists.
- B. Comply with AWS requirements and procedures for shop welding, appearance, quality of welds, and methods used in correcting welding work.
- C. Provide holes in chord members for connecting and securing other construction to joists.
- D. Top-Chord Extensions: Extend top chords of joists with SJI's Type S top-chord extensions where indicated, complying with SJI's "Specifications."
- E. Extended Ends: Extend bearing ends of joists with SJI's Type R extended ends where indicated, complying with SJI's "Specifications."
- F. Do not camber joist unless specifically noted to do so.
- G. Equip bearing ends of joists with manufacturer's standard beveled ends or sloped shoes if joist slope exceeds 1/4 inch per 12 inches (1:48).

2.4 JOIST ACCESSORIES

- A. Bridging: Provide bridging anchors and number of rows of horizontal and/or diagonal bridging of material, size, and type required by SJI's "Specifications" for type of joist, chord size, spacing, and span. Furnish additional erection bridging if required for stability.

- B. Fabricate steel bearing plates with integral anchorages of sizes and thicknesses indicated. Shop prime paint.
- C. Supply ceiling extensions, either extended bottom-chord elements or a separate extension unit of enough strength to support ceiling construction. Extend ends to within 1/2 inch (13 mm) of finished wall surface, unless otherwise indicated.
- D. Supply miscellaneous accessories, including splice plates and bolts required by joist manufacturer to complete joist installation.

2.5 CLEANING AND SHOP PAINTING

- A. Clean and remove loose scale, heavy rust, and other foreign materials from fabricated joists and accessories by power-tool cleaning, SSPC-SP 3.
- B. Do not prime paint joists and accessories to receive sprayed fire-resistive materials.
- C. Apply 1 coat of shop primer to joists and joist accessories at concealed locations to be primed to provide a continuous, dry paint film not less than 1 mil (0.025 mm) thick.
- D. Shop priming of joists and joist accessories at exposed locations is specified in Division 09 painting Sections.

PART 3 - EXECUTION

3.1 EXAMINATION

- A. Examine supporting substrates, embedded bearing plates, and abutting structural framing for compliance with requirements for installation tolerances and other conditions affecting performance.
 - 1. Proceed with installation only after unsatisfactory conditions have been corrected.

3.2 INSTALLATION

- A. Do not install joists until supporting construction is in place and secured.
- B. Install joists and accessories plumb, square, and true to line; securely fasten to supporting construction according to SJI's "Specifications," joist manufacturer's written recommendations, and requirements in this Section.
 - 1. Before installation, splice joists delivered to Project site in more than one piece.
 - 2. Space, adjust, and align joists accurately in location before permanently fastening.
 - 3. Install temporary bracing and erection bridging, connections, and anchors to ensure that joists are stabilized during construction.
 - 4. Delay rigidly connecting bottom-chord extensions to columns or supports until dead loads have been applied.

- C. Field weld joists to supporting steel bearing plates and framework. Coordinate welding sequence and procedure with placement of joists. Comply with AWS requirements and procedures for welding, appearance and quality of welds, and methods used in correcting welding work.
- D. Install and connect bridging concurrently with joist erection, before construction loads are applied. Anchor ends of bridging lines at top and bottom chords if terminating at walls or beams.

3.3 FIELD QUALITY CONTROL

- A. Testing Agency: Owner will engage a qualified independent testing and inspecting agency to inspect field welds and bolted connections and to perform field tests and inspections and prepare test and inspection reports.
- B. Field welds will be visually inspected according to AWS D1.1/D1.1M.
- C. In addition to visual inspection, field welds will be tested according to AWS D1.1/D1.1M and the following procedures, as applicable:
 - 1. Radiographic Testing: ASTM E 94.
 - 2. Magnetic Particle Inspection: ASTM E 709.
 - 3. Ultrasonic Testing: ASTM E 164.
 - 4. Liquid Penetrant Inspection: ASTM E 165.
- D. Bolted connections will be visually inspected.
- E. High-strength, field-bolted connections will be tested and verified according to procedures in RCSC's "Specification for Structural Joints Using ASTM A 325 or ASTM A 490 Bolts."
- F. Correct deficiencies in Work that test and inspection reports have indicated are not in compliance with specified requirements.
- G. Additional testing will be performed to determine compliance of corrected Work with specified requirements.

3.4 REPAIRS AND PROTECTION

- A. Touchup Painting: After installation, promptly clean, prepare, and prime or reprime field connections, rust spots, and abraded surfaces of prime-painted joists, bearing plates, abutting structural steel, and accessories.
 - 1. Clean and prepare surfaces by hand-tool cleaning, SSPC-SP 2, or power-tool cleaning, SSPC-SP 3.
 - 2. Apply a compatible primer of same type as shop primer used on adjacent surfaces.
- B. Provide final protection and maintain conditions, in a manner acceptable to manufacturer and Installer, that ensure that joists and accessories are without damage or deterioration at time of Substantial Completion.

END OF SECTION 052100

THIS PAGE INTENTIONALLY BLANK

SECTION 053100 - STEEL DECKING

PART 1 - GENERAL

1.1 RELATED DOCUMENTS

- A. Drawings and general provisions of Contract, including General and Supplementary Conditions and other Division-1 Specification Sections, apply to this Section.

1.2 SUMMARY

- A. This Section includes the following:

- 1. Roof deck.
- 2. Floor deck.

- B. Related Requirements:

- 1. Section 033000 "Cast-in-Place Concrete" for normal-weight concrete fill over steel deck.
- 2. Section 055000 "Metal Fabrications" for framing deck openings with miscellaneous steel shapes.

1.3 SUBMITTALS

- A. Product Data: For each type of deck, accessory, and product indicated.
- B. Shop Drawings: Show layout and types of deck panels, anchorage details, reinforcing channels, pans, cut deck openings, special jointing, accessories, and attachments to other construction. Indicate temporary deck shoring, where required, follow manufacturers recommendations.
- C. Product Certificates: For each type of steel deck, signed by product manufacturer.
- D. Welding certificates.
- E. Field quality-control test and inspection reports.
- F. Product Test Reports: Based on evaluation of comprehensive tests performed by a qualified testing agency, indicating that each of the following complies with requirements:
 - 1. Power-actuated mechanical fasteners.
- G. Research/Evaluation Reports: For steel deck (ICC-ES or IAPMO valid report).

1.4 QUALITY ASSURANCE

- A. Welding: Qualify procedures and personnel according to AWS D1.3, "Structural Welding Code - Sheet Steel."
- B. AISI Specifications: Comply with calculated structural characteristics of steel deck according to AISI's "North American Specification for the Design of Cold-Formed Steel Structural Members."

1.5 DELIVERY, STORAGE, AND HANDLING

- A. Protect steel deck from corrosion, deformation, and other damage during delivery, storage, and handling.
- B. Stack steel deck on platforms or pallets and slope to provide drainage. Protect with a waterproof covering and ventilate to avoid condensation.
 - 1. Protect and ventilate acoustical cellular roof deck with factory-installed insulation to maintain insulation free of moisture.

PART 2 - PRODUCTS

2.1 PERFORMANCE REQUIREMENTS

- A. AISI Specifications: Comply with calculated structural characteristics of steel deck according to AISI's "North American Specification for the Design of Cold-Formed Steel Structural Members."

2.2 MANUFACTURERS

- A. Manufacturers: Subject to compliance with requirements, provide products by one of the following:
 - a. Nucor Corp.; Vulcraft Division.
 - b. ASC Profiles, Inc.; a Blue Scope Steel company.
 - c. Vercor Manufacturing Co.
 - d. EPIC Metals Corporation
 - e. Products by other manufacturers with current testing report are subject to approval prior to bidding.

2.3 ROOF DECK

- A. Steel Roof Deck: Fabricate panels, without top-flange stiffening grooves, to comply with "SDI Specifications and Commentary for Steel Roof Deck," in SDI Publication No. 30, and with the following:

1. Galvanized Steel Sheet: ASTM A 653/A 653M, Structural Steel (SS) – Gr 50 ksi, min. , G60 zinc coating.
 2. Deck Profile: As indicated in drawings.
 3. Profile Depth: As indicated in drawings.
 4. Design Uncoated-Steel Thickness: As indicted in drawings.
 5. Span Condition: As indicated in drawings.
 6. Side Laps: Overlapped, and fastened as indicated on drawings.
- B. Steel Floor Deck: Fabricate panels to comply with "SDI Specifications and Commentary for Steel Floor Deck," in SDI Publication No. 30, and with the following:
1. Galvanized Steel Sheet: ASTM A 653/A 653M, Structural Steel (SS) – Gr 50 ksi, min., G60 zinc coating.
 2. Deck Profile: As indicated in drawings.
 3. Profile Depth: As indicated in drawings.
 4. Design Uncoated-Steel Thickness: As indicted in drawings.
 5. Span Condition: As indicated in drawings.
 6. Side Laps: Overlapped, and fastened as indicated on drawings.

2.4 ACCESSORIES

- A. General: Provide manufacturer's standard accessory materials for deck that comply with requirements indicated.
- B. Mechanical Fasteners: Corrosion-resistant, low-velocity, power-actuated or pneumatically driven carbon-steel fasteners with current ICC-ES reports; or self-drilling, self-threading screws with current ICC-ES reports.
- C. Side-Lap Fasteners: As indicated in the drawings and per the manufacturer's recommendations.
- D. Flexible Closure Strips: Vulcanized, closed-cell, synthetic rubber.
- E. Miscellaneous Sheet Metal Deck Accessories: Steel sheet, minimum yield strength of 33,000 psi (230 MPa) to match deck strength, not less than 0.0359-inch (0.91-mm) design uncoated thickness, of same material and finish as deck; of profile indicated or required for application.
- F. Pour Stops and Girder Fillers: Steel sheet, minimum yield strength of 33,000 psi (230 MPa), of same material and finish as deck, and of thickness and profile indicated.
- G. Column Closures, End Closures, Z-Closures, and Cover Plates: Steel sheet, of same material, finish, and thickness as deck, unless otherwise indicated.
- H. Piercing Hanger Tabs: Piercing steel sheet hanger attachment devices for use with floor deck.
- I. Weld Washers: Uncoated steel sheet, shaped to fit deck rib, 0.0747 inch (1.90 mm) thick, with factory-punched hole of 3/8-inch (9.5-mm) minimum diameter.

- J. Recessed Sump Pans: Single-piece steel sheet, 0.0747 inch (1.90 mm) thick, of same material and finish as deck, with 3-inch- (76-mm-) wide flanges and level recessed pans of 1-1/2-inch (38-mm) minimum depth. For drains, cut holes in the field.
- K. Galvanizing Repair Paint: ASTM A 780.

PART 3 - EXECUTION

3.1 EXAMINATION

- A. Examine supporting frame and field conditions for compliance with requirements for installation tolerances and other conditions affecting performance.

3.2 INSTALLATION, GENERAL

- A. Install deck panels and accessories according to applicable specifications and commentary in SDI Publication No. 30, manufacturer's written instructions, and requirements in this Section.
- B. Install temporary shoring before placing deck panels, if required to meet deflection limitations.
- C. Locate deck bundles to prevent overloading of supporting members.
- D. Place deck panels on supporting frame and adjust to final position with ends accurately aligned and bearing on supporting frame before being permanently fastened. Do not stretch or contract side-lap interlocks.
- E. Place deck panels flat and square and fasten to supporting frame without warp or deflection.
- F. Cut and neatly fit deck panels and accessories around openings and other work projecting through or adjacent to deck.
- G. Provide additional reinforcement and closure pieces at openings as required for strength, continuity of deck, and support of other work.
- H. Comply with AWS requirements and procedures for manual shielded metal arc welding, appearance and quality of welds, and methods used for correcting welding work.

3.3 ROOF AND FLOOR DECK INSTALLATION

- A. Fasten floor and roof-deck panels to steel supporting members by arc spot (puddle) welds as indicated on Drawings.
- B. Side-Lap and Perimeter Edge Fastening: As indicated on Drawings.
- C. End Bearing: Install deck ends over supporting frame as indicated on drawings with a minimum end bearing of 1-1/2 inches (38 mm) for roof deck and 2 inches (51 mm) for floor deck, with end joints as follows:

1. End Joints: Lapped 2 inches (51 mm) minimum.
- D. Roof Sump Pans and Sump Plates: Install over openings provided in roof deck and weld top of deck. Space welds not more than 12 inches (305 mm) apart with at least one weld at each corner.
1. Install reinforcing channels or zees in ribs to span between supports and weld or mechanically fasten.
- E. Miscellaneous Roof and Floor Deck Accessories: Install ridge and valley plates, finish strips, end closures, and reinforcing channels according to deck manufacturer's written instructions. Weld or mechanically fasten to substrate to provide a complete deck installation.
1. Weld cover plates at changes in direction of roof-deck panels, unless otherwise indicated.
- F. Flexible Closure Strips: Install flexible closure strips over partitions, walls, and where indicated. Install with adhesive according to manufacturer's written instructions to ensure complete closure.
- G. Galvanizing Paint: Paint all welds with galvanizing repair paint.

3.4 FIELD QUALITY CONTROL

- A. Testing Agency: Owner will engage a qualified independent testing and inspecting agency to perform field tests and inspections and prepare test reports.
- B. Field welds will be subject to inspection.
- C. Testing agency will report inspection results promptly and in writing to Contractor and Architect.
- D. Remove and replace work that does not comply with specified requirements.
- E. Additional inspecting, at Contractor's expense, will be performed to determine compliance of corrected work with specified requirements.

3.5 REPAIRS AND PROTECTION

- A. Galvanizing Repairs: Prepare and repair damaged galvanized coatings on both surfaces of deck with galvanized repair paint according to ASTM A 780 and manufacturer's written instructions.
- B. Provide final protection and maintain conditions to ensure that steel deck is without damage or deterioration at time of Substantial Completion.

END OF SECTION 053100

THIS PAGE INTENTIONALLY BLANK

SECTION 054000 - COLD-FORMED METAL FRAMING

PART 1 - GENERAL

1.1 RELATED DOCUMENTS

- A. Drawings and general provisions of Contract, including General and Supplementary Conditions and other Division-1 Specification Sections, apply to this Section.
- B. AISI S100 and AISI S200

1.2 SUMMARY

- A. This Section includes the following:
 - 1. Incidental interior load-bearing wall framing: Standard C shaped, punched steel studs, steel box or back to back headers, and U-shaped, unpunched track.
- B. Related Requirements:
 - 1. Section 051200 Structural Steel Framing.
 - 2. Section 092216 "Non-Structural Metal Framing" for interior, non-load-bearing, metal-stud framing and short-span ceiling joist framing.

1.3 SUBMITTALS

- A. Product Data: For each type of cold-formed metal framing product and accessory indicated.
- B. Shop Drawings: Show layout, spacings, sizes, thicknesses, and types of cold-formed metal framing; fabrication; and fastening and anchorage details, including mechanical fasteners and welded attachments. Show reinforcing channels, opening framing, supplemental framing, strapping, bracing, bridging, splices, accessories, connection details, and attachment to adjoining work, including deflection tracks where indicated in the drawings.
- C. Substitution Requests: Substitution request for changes in the framing made by the contractor shall be submitted in writing to the owner, architect and engineer for approval prior to procurement, fabrication or erection. All requests shall have backing structural calculations signed and stamped by a licensed State of Idaho civil engineer and submitted with the substitution request.
- D. Welding certificates.
- E. Research/Evaluation Reports: For cold-formed metal framing (ICC-ES valid reports).

1.4 QUALITY ASSURANCE

- A. Welding: Qualify procedures and personnel according to AWS D1.1/D1.1M, "Structural Welding Code--Steel," and AWS D1.3, "Structural Welding Code--Sheet Steel."
- B. Fire-Test-Response Characteristics: Where indicated, provide cold-formed metal framing identical to that of assemblies tested for fire resistance per ASTM E 119 by a testing and inspecting agency acceptable to authorities having jurisdiction.
- C. AISI Specifications and Standards: Comply with AISI's "North American Specification for the Design of Cold-Formed Steel Structural Members" and its "Standard for Cold-Formed Steel Framing - General Provisions."

1.5 DELIVERY, STORAGE, AND HANDLING

- A. Protect cold-formed metal framing from corrosion, deformation, and other damage during delivery, storage, and handling.
- B. Store cold-formed metal framing, protect with a waterproof covering, and ventilate to avoid condensation.

PART 2 - PRODUCTS

2.1 MANUFACTURERS

- A. Manufacturers: Subject to compliance with requirements, provide cold-formed metal framing by one of the following:
 - 1. Dietrich Metal Framing; a Worthington Industries Company (ICC-ESR-1166P).
 - 2. SCAFCO Corporation (ICC-ESR-3064P).
 - 3. Steeler, Inc (ICC-ESR-4205).
- B. Products by other manufacturers with current ICC-ESR are subject to approval prior to bidding.

2.2 MATERIALS

- A. Steel Sheet: ASTM A 1003/A 1003M, Structural Grade, Type H, metallic coated, of grade and coating weight as follows:
 - 1. Grade: ST50H (ST340H).
 - 2. Coating: G60 (Z180).
- B. Steel Sheet for Clips: ASTM A 653/A 653M, structural steel, zinc coated, of grade and coating as follows:
 - 1. Grade: 50 (340), Class 1 or 2.
 - 2. Coating: G90 (Z275).

2.3 WALL FRAMING

- A. Steel Studs: Manufacturer's standard C-shaped steel studs, of web depths indicated, punched (interior only), with stiffened flanges, and as follows:
 - 1. Minimum Base-Metal Thickness: As indicated in the drawings.
 - 2. Flange Width: As indicated in the drawings.
- B. Steel Track: Manufacturer's standard U-shaped steel track, of web depths indicated, unpunched, with unstiffened flanges, and as follows:
 - 1. Minimum Base-Metal Thickness: As indicated in the drawings.
 - 2. Flange Width: As indicated in the drawings.

2.4 FRAMING ACCESSORIES

- A. Fabricate steel-framing accessories from steel sheet, ASTM A 1003/A 1003M, Structural Grade, Type H, metallic coated, of same grade and coating weight used for framing members.
- B. As required, provide accessories of manufacturer's standard thickness and configuration, unless otherwise indicated, as follows:
 - 1. Supplementary framing.
 - 2. Bracing, bridging, and solid blocking.
 - 3. Web stiffeners.
 - 4. Anchor clips.
 - 5. End clips.
 - 6. Foundation clips.
 - 7. Gusset plates.
 - 8. Stud kickers, knee braces, and girts.
 - 9. Joist hangers and end closures.
 - 10. Hole reinforcing plates.
 - 11. Backer plates.

2.5 ANCHORS, CLIPS, AND FASTENERS

- A. Steel Shapes and Clips: As indicated in the drawings.
- B. Anchor Bolts: As indicated in the drawings.
- C. Expansion Anchors: As indicated in the drawings.
- D. Power-Actuated Anchors: Fastener system of type suitable for application indicated, fabricated from corrosion-resistant materials, with capability to sustain, without failure, a load equal to 10 times design load, as determined by testing per ASTM E 1190 conducted by a qualified independent testing agency with current ICC-ESR.
- E. Mechanical Fasteners:
 - 1. Products:
 - a. Elco Drill-Flex (ICC ESR-3294).

2. Head Type: Low-profile head beneath sheathing, manufacturer's standard elsewhere.

F. Welding Electrodes: Comply with AWS standards.

2.6 MISCELLANEOUS MATERIALS

A. Galvanizing Repair Paint: ASTM A 780.

B. Cement Grout: Portland cement, ASTM C 150, Type I; and clean, natural sand, ASTM C 404. Mix at ratio of 1 part cement to 2-1/2 parts sand, by volume, with minimum water required for placement and hydration.

C. Nonmetallic, Nonshrink Grout: Premixed, nonmetallic, noncorrosive, nonstaining grout containing selected silica sands, portland cement, shrinkage-compensating agents, and plasticizing and water-reducing agents, complying with ASTM C 1107, with fluid consistency and 30-minute working time.

D. Shims: Load bearing, high-density multimonomer plastic, nonleaching.

2.7 FABRICATION

A. Fabricate cold-formed metal framing and accessories plumb, square, and true to line, and with connections securely fastened, according to referenced AISI's specifications and standards, manufacturer's written instructions, and requirements in this Section.

1. Fabricate framing assemblies using jigs or templates.

2. Cut framing members by sawing or shearing with clean edges; do not torch cut.

3. Fasten cold-formed metal framing members by welding, screw fastening, clinch fastening, or riveting as standard with fabricator. Wire tying of framing members is not permitted.

a. Comply with AWS D1.3 requirements and procedures for welding, appearance and quality of welds, and methods used in correcting welding work.

b. Locate mechanical fasteners and install according to Shop Drawings, with screw penetrating joined members by not less than three exposed screw threads.

4. Fasten other materials to cold-formed metal framing by welding, bolting, or screw fastening, according to Shop Drawings.

B. Reinforce, stiffen, and brace framing assemblies to withstand handling, delivery, and erection stresses. Lift fabricated assemblies to prevent damage or permanent distortion.

C. Fabrication Tolerances: Fabricate assemblies level, plumb, and true to line to a maximum allowable tolerance variation of 1/8 inch in 10 feet (1:960) and as follows:

1. Spacing: Space individual framing members no more than plus or minus 1/8 inch (3 mm) from plan location. Cumulative error shall not exceed minimum fastening requirements of sheathing or other finishing materials.

2. Squareness: Fabricate each cold-formed metal framing assembly to a maximum out-of-square tolerance of 1/8 inch (3 mm).

PART 3 - EXECUTION

3.1 EXAMINATION

- A. Examine supporting substrates and abutting structural framing for compliance with requirements for installation tolerances and other conditions affecting performance.
 - 1. Proceed with installation only after unsatisfactory conditions have been corrected.

3.2 PREPARATION

- A. Install load bearing shims or grout between the underside of wall bottom track or rim track and the top of foundation wall or slab at stud or joist locations to ensure a uniform bearing surface on supporting concrete or masonry construction.
- B. Install sealer gaskets to isolate the underside of wall bottom track or rim track and the top of foundation wall or slab at stud or joist locations.

3.3 INSTALLATION, GENERAL

- A. Cold-formed metal framing may be shop or field fabricated for installation, or it may be field assembled.
- B. Install cold-formed metal framing according to AISI's "Standard for Cold-Formed Steel Framing - General Provisions" and to manufacturer's written instructions unless more stringent requirements are indicated.
- C. Install shop- or field-fabricated, cold-formed framing and securely anchor to supporting structure.
 - 1. Screw, bolt, or weld wall panels at horizontal and vertical junctures to produce flush, even, true-to-line joints with maximum variation in plane and true position between fabricated panels not exceeding 1/16 inch (1.6 mm).
- D. Install cold-formed metal framing and accessories plumb, square, and true to line, and with connections securely fastened.
 - 1. Cut framing members by sawing or shearing with clean edges; do not torch cut.
 - 2. Fasten cold-formed metal framing members by welding, screw fastening, clinch fastening, or riveting. Wire tying of framing members is not permitted.
 - a. Comply with AWS D1.3 requirements and procedures for welding, appearance and quality of welds, and methods used in correcting welding work.
 - b. Locate mechanical fasteners and install according to Shop Drawings, and complying with requirements for spacing, edge distances, and screw penetration.
- E. Install framing members in one-piece lengths unless splice connections are indicated for track or tension members.

- F. Install temporary bracing and supports to secure framing and support loads comparable in intensity to those for which structure was designed. Maintain braces and supports in place, undisturbed, until entire integrated supporting structure has been completed and permanent connections to framing are secured.
- G. Do not bridge building expansion and control joints with cold-formed metal framing. Independently frame both sides of joints.
- H. Fasten hole reinforcing plate over web penetrations that exceed size of manufacturer's standard punched openings.
- I. Erection Tolerances: Install cold-formed metal framing level, plumb, and true to line to a maximum allowable tolerance variation of 1/8 inch in 10 feet (1:960) and as follows:
 - 1. Space individual framing members no more than plus or minus 1/8 inch (3 mm) from plan location. Cumulative error shall not exceed minimum fastening requirements of sheathing or other finishing materials.

3.4 WALL INSTALLATION

- A. Install continuous tracks sized to match studs. Align tracks accurately and securely anchor to supporting structure as indicated in architectural or structural drawings.
- B. Fasten both flanges of studs to top and bottom track, unless otherwise indicated. Space studs as indicated in architectural or structural drawings.
- C. Set studs plumb, except as needed for diagonal bracing or required for non-plumb walls or warped surfaces and similar requirements.
- D. Isolate non-load-bearing steel framing from building structure to prevent transfer of vertical loads while providing lateral support.
- E. Install horizontal bridging in wall studs, spaced in rows indicated, but not more than 48 inches (1220 mm) apart. Fasten at each stud intersection.
 - 1. Top Bridging for Single Deflection Track: Install row of horizontal bridging within 12 inches (305 mm) of single deflection track. Install a combination of flat, taut, steel sheet straps of width and thickness indicated and stud or stud-track solid blocking of width and thickness matching studs. Fasten flat straps to stud flanges and secure solid blocking to stud webs or flanges. At minimum follow SSMA guidelines.
 - a. Install solid blocking at centers indicated.
 - 2. Bridging: Cold-rolled steel channel, welded or mechanically fastened to webs of punched studs.
- F. Install miscellaneous framing and connections, including stud kickers, web stiffeners, clip angles, continuous angles, anchors, fasteners, and stud girts, to provide a complete and stable wall-framing system.

3.5 FIELD QUALITY CONTROL

- A. Testing: Owner will engage a qualified independent testing and inspecting agency to perform field tests and inspections and prepare test reports.
- B. Field and shop welds will be subject to testing and inspecting.
- C. Testing agency will report test results promptly and in writing to Contractor and Architect.
- D. Remove and replace work where test results indicate that it does not comply with specified requirements.
- E. Additional testing and inspecting, at Contractor's expense, will be performed to determine compliance of replaced or additional work with specified requirements.

3.6 REPAIRS AND PROTECTION

- A. Galvanizing Repairs: Prepare and repair damaged galvanized coatings on fabricated and installed cold-formed metal framing with galvanized repair paint according to ASTM A 780 and manufacturer's written instructions.
- B. Provide final protection and maintain conditions, in a manner acceptable to manufacturer and Installer, that ensure that cold-formed metal framing is without damage or deterioration at time of Substantial Completion.

END OF SECTION 054000

THIS PAGE INTENTIONALLY BLANK

SECTION 055000 - METAL FABRICATIONS

PART 1 - GENERAL

1.1 RELATED DOCUMENTS

- A. Drawings and general provisions of the Contract, including General and Supplementary Conditions and Division 01 Specification Sections, apply to this Section.

1.2 SUMMARY

- A. This Section includes the following:
 - 1. Miscellaneous steel framing and supports.
 - 2. Ledger angles and bearing seats.
 - 3. Steel bollards/posts.
 - 4. Steel ladders, roof and floor door.
 - 5. Miscellaneous structural fabrications and anchor bolts.
- B. Products furnished, but not installed, under this Section include the following:
 - 1. Anchor bolts indicated to be cast into concrete or built into unit masonry.

1.3 SUBMITTALS

- A. Shop Drawings: Show fabrication and installation details for metal fabrications.
 - 1. Include plans, elevations, sections, and details of metal fabrications and their connections. Show anchorage and accessory items.
 - 2. Provide templates for anchors and bolts specified for installation under other Sections.
- B. Welding certificates.

1.4 QUALITY ASSURANCE

- A. Welding: Qualify procedures and personnel according to the following American Welding Society (AWS) codes:
 - 1. AWS D1.1, "Structural Welding Code--Steel."
 - 2. AWS D1.3, "Structural Welding Code--Sheet Steel."

1.5 PROJECT CONDITIONS

- A. Field Measurements: Verify actual locations of walls and other construction contiguous with metal fabrications by field measurements before fabrication and indicate measurements on Shop Drawings.
 - 1. Established Dimensions: Where field measurements cannot be made without delaying the Work, establish dimensions and proceed with fabricating metal fabrications without field measurements. Coordinate wall and other contiguous construction to ensure that actual dimensions correspond to established dimensions.
 - 2. Provide allowance for trimming and fitting at site.

1.6 COORDINATION

- A. Coordinate installation of anchorages for metal fabrications. Furnish setting drawings, templates, and directions for installing anchorages, including sleeves, concrete inserts, anchor bolts, and items with integral anchors, that are to be embedded in concrete or masonry. Deliver such items to Project site in time for installation.
- B. Coordinate installation of steel weld plates and angles for casting into concrete or building into masonry that are specified in this Section but required for work of another Section. Deliver such items to Project site in time for installation.

PART 2 - PRODUCTS

2.1 MANUFACTURERS

- A. In other Part 2 articles where titles below introduce lists, the following requirements apply to product selection:
 - 1. Products: Subject to compliance with requirements, provide one of the products specified.
 - 2. Manufacturers: Subject to compliance with requirements, provide products by one of the manufacturers specified.
- B. Products by other manufacturers are subject to approval by the Architect prior to bidding.

2.2 METALS, GENERAL

- A. Metal Surfaces, General: Provide materials with smooth, flat surfaces, unless otherwise indicated. For metal fabrications exposed to view in the completed Work, provide materials without seam marks, roller marks, rolled trade names, or blemishes.

2.3 FERROUS METALS

- A. Steel Plates, Shapes, and Bars: ASTM A 36/A 36M.

- B. Steel Pipe: ASTM A 53/A 53M, Type F or Type S, standard weight (Schedule 40), unless another weight is indicated or required by structural loads.
- C. Hollow Structural Sections: ASTM A 500, structural tubing.
- D. Wide Flange Section: ASTM A 992

2.4 FASTENERS

- A. General: Unless otherwise indicated, provide Type 304 stainless-steel fasteners for exterior use and zinc-plated fasteners with coating complying with ASTM B 633, Class Fe/Zn 5, at other locations.
- B. Steel Bolts and Nuts: Regular hexagon-head bolts, ASTM A 307, Grade A (ASTM F 568M, Property Class 4.6); with hex nuts, ASTM A 563 (ASTM A 563M); and, where indicated, flat washers.
- C. Anchor Bolts: ASTM F 1554, Grade 36 unless otherwise indicated on drawings.
 - 1. Provide hot-dip or mechanically deposited, zinc-coated anchor bolts where item being fastened is indicated to be galvanized.
- D. Eyebolts: ASTM A 489.
- E. Machine Screws: American Society of Mechanical Engineers International (ASME) ASME B18.6.3 (ASME B18.6.7M).
- F. Lag Bolts: ASME B18.2.1 (ASME B18.2.3.8M).
- G. Wood Screws: Flat head, ASME B18.6.1.
- H. Plain Washers: Round, ASME B18.22.1 (ASME B18.22M).
- I. Lock Washers: Helical, spring type, ASME B18.21.1 (ASME B18.21.2M).
- J. Cast-in-Place Anchors in Concrete: Anchors capable of sustaining, without failure, a load equal to four times the load imposed, as determined by testing according to ASTM E 488, conducted by a qualified independent testing agency.
 - 1. Threaded or wedge type; galvanized ferrous castings, either ASTM A 47/A 47M malleable iron or ASTM A 27/A 27M cast steel. Provide bolts, washers, and shims as needed, hot-dip galvanized per ASTM A 153/A 153M.

2.5 MISCELLANEOUS MATERIALS

- A. Welding Rods and Bare Electrodes: Select according to American Welding Society (AWS) specifications for metal alloy welded.
- B. Shop Primers: Provide primers that comply with Division 09 painting Sections.

- C. Bituminous Paint: Cold-applied asphalt emulsion complying with ASTM D 1187.
- D. Nonshrink, Nonmetallic Grout: Factory-packaged, nonstaining, noncorrosive, nongaseous grout complying with ASTM C 1107. Provide grout specifically recommended by manufacturer for interior and exterior applications.

2.6 FABRICATION, GENERAL

- A. Shop Assembly: Preassemble items in the shop to greatest extent possible. Disassemble units only as necessary for shipping and handling limitations. Use connections that maintain structural value of joined pieces. Clearly mark units for reassembly and coordinated installation.
- B. Cut, drill, and punch metals cleanly and accurately. Remove burrs and ease edges to a radius of approximately 1/32 inch (1 mm), unless otherwise indicated. Remove sharp or rough areas on exposed surfaces.
- C. Form bent-metal corners to smallest radius possible without causing grain separation or otherwise impairing work.
- D. Form exposed work true to line and level with accurate angles and surfaces and straight edges.
- E. Weld corners and seams continuously to comply with the following:
 - 1. Use materials and methods that minimize distortion and develop strength and corrosion resistance of base metals.
 - 2. Obtain fusion without undercut or overlap.
 - 3. Remove welding flux immediately.
 - 4. At exposed connections, finish exposed welds and surfaces smooth and blended so no roughness shows after finishing and contour of welded surface matches that of adjacent surface.
- F. Form exposed connections with hairline joints, flush and smooth, using concealed fasteners where possible. Where exposed fasteners are required, use Phillips flat-head (countersunk) screws or bolts, unless otherwise indicated. Locate joints where least conspicuous.
- G. Fabricate seams and other connections that will be exposed to weather in a manner to exclude water. Provide weep holes where water may accumulate.
- H. Cut, reinforce, drill, and tap metal fabrications as indicated to receive finish hardware, screws, and similar items.
- I. Provide for anchorage of type indicated; coordinate with supporting structure. Space anchoring devices to secure metal fabrications rigidly in place and to support indicated loads.
 - 1. Where units are indicated to be cast into concrete or built into masonry, equip with integrally welded steel strap anchors, 1/8 by 1-1/2 inches (3.2 by 38 mm), with a minimum 6-inch (150-mm) embedment and 2-inch (50-mm) hook, not less than 8 inches (200 mm) from ends and corners of units and 24 inches (600 mm) o.c., unless otherwise indicated.

2.7 MISCELLANEOUS FRAMING AND SUPPORTS

- A. General: Provide steel framing and supports not specified in other Sections as needed to complete the Work.
- B. Fabricate units from steel shapes, plates, and bars of welded construction, unless otherwise indicated. Fabricate to sizes, shapes, and profiles indicated and as necessary to receive adjacent construction retained by framing and supports. Cut, drill, and tap units to receive hardware, hangers, and similar items.
 - 1. Fabricate units from slotted channel framing where indicated.
 - 2. Furnish inserts if units are installed after concrete is placed.
- C. Prime miscellaneous framing and supports with zinc-rich primer except where galvanizing is indicated.

2.8 LEDGER ANGLES AND BEARING SEATS

- A. Fabricate ledger angles and bearing seats from steel angles and plate of sizes indicated and for attachment to concrete and masonry construction.

2.9 METAL BOLLARDS

- A. Fabricate metal bollards from Schedule forty (40) steel pipe or as indicated.
 - 1. Cap bollards with 1/4-inch-(6.4-mm-) thick steel plate or as indicated.
 - 2. Where bollards are indicated to receive controls for door operators, provide cutouts for controls and holes for wire.
- B. Fabricate sleeves for bollard anchorage from steel pipe, or as indicated, with 1/4-inch-(6.4-mm-) thick steel plate welded to bottom of sleeve. Make sleeves not less than twenty-four (24) inches (600 mm) deep and 3/4-inch (19 mm) larger than OD of bollard.
- C. Fabricate internal sleeves for removable bollards from Schedule 40 steel pipe or 1/4-inch (6.4-mm) wall-thickness steel tubing with an OD approximately 1/16-inch (1.5 mm) less than ID of bollards. Match drill sleeve and bollard for 3/4-inch (19-mm) steel machine bolt.
- D. Prime and finish bollards as specified in Section 099600 "High-Performance Coatings."

2.10 METAL LADDERS

- A. General:
 - 1. Comply with ANSI A14.3, except for elevator pit ladders.
 - 2. For elevator pit ladders, comply with ASME A17.1/CSA B44.
- B. Steel Ladders:
 - 1. Space siderails eighteen (18) inches (457 mm) apart unless otherwise indicated.
 - 2. Siderails: Continuous, 3/8" x 3" steel flat bars, with eased edges.
 - 3. Rungs: One (1) inch diameter steel bars.
 - 4. Fit rungs in centerline of siderails; plug-weld and grind smooth on outer rail faces.

5. Provide nonslip surfaces on top of each rung, either by coating rung with aluminum-oxide granules set in epoxy-resin adhesive or by using a type of manufactured rung filled with aluminum-oxide grout.
6. Provide platforms as indicated fabricated from welded or pressure-locked steel bar grating, supported by steel angles. Limit openings in gratings to no more than 1/2 inch (12 mm) in least dimension.
7. Support each ladder at top and bottom and not more than thirty (30) inches (7500 mm) o.c. with welded or bolted steel brackets. Refer to details for additional requirements. Utilize Details on Drawings for additional information and if noted otherwise.

2.11 FINISHES, GENERAL

- A. Comply with National Association of Architectural Metal Manufacturer's (NAAMM) "Metal Finishes Manual for Architectural and Metal Products" for recommendations for applying and designating finishes.
- B. Finish metal fabrications after assembly.

2.12 STEEL AND IRON FINISHES

- A. Preparation for Shop Priming: Prepare uncoated ferrous-metal surfaces to comply with minimum requirements indicated below for the Society for Protective Coatings (SSPC) surface preparation specifications and environmental exposure conditions of installed metal fabrications:
 1. Exteriors SSPC Zone 1B and Items Indicated to Receive Zinc-Rich Primer: SSPC-SP 6/NACE No. 3, "Commercial Blast Cleaning."
 2. Interiors (SSPC Zone 1A): SSPC-SP 3, "Power Tool Cleaning."
- B. Shop Priming: Apply shop primer to uncoated surfaces of metal fabrications, except those with galvanized finishes and those to be embedded in concrete, sprayed-on fireproofing, or masonry, unless otherwise indicated. Comply with SSPC-PA 1, "Paint Application Specification No. 1: Shop, Field, and Maintenance Painting of Steel," for shop painting.
 1. Stripe paint corners, crevices, bolts, welds, and sharp edges.

PART 3 - EXECUTION

3.1 INSTALLATION, GENERAL

- A. Cutting, Fitting, and Placement: Perform cutting, drilling, and fitting required for installing metal fabrications. Set metal fabrications accurately in location, alignment, and elevation; with edges and surfaces level, plumb, true, and free of rack; and measured from established lines and levels.

- B. Fit exposed connections accurately together to form hairline joints. Weld connections that are not to be left as exposed joints but cannot be shop welded because of shipping size limitations. Do not weld, cut, or abrade surfaces of exterior units that have been hot-dip galvanized after fabrication and are for bolted or screwed field connections.
- C. Field Welding: Comply with the following requirements:
 - 1. Use materials and methods that minimize distortion and develop strength and corrosion resistance of base metals.
 - 2. Obtain fusion without undercut or overlap.
 - 3. Remove welding flux immediately.
 - 4. At exposed connections, finish exposed welds and surfaces smooth and blended so no roughness shows after finishing and contour of welded surface matches that of adjacent surface.
- D. Fastening to In-Place Construction: Provide anchorage devices and fasteners where metal fabrications are required to be fastened to in-place construction. Provide threaded fasteners for use with concrete and masonry inserts, toggle bolts, through bolts, lag bolts, wood screws, and other connectors.
- E. Provide temporary bracing or anchors in formwork for items that are to be built into concrete, masonry, or similar construction.

3.2 INSTALLING MISCELLANEOUS FRAMING AND SUPPORTS

- A. General: Install framing and supports to comply with requirements of items being supported, including manufacturers' written instructions and requirements indicated on Shop Drawings.
- B. Anchor supports for operable partitions, overhead doors, and overhead grilles securely to, and rigidly brace from, building structure.

3.3 INSTALLING METAL BOLLARDS

- A. Fill metal-capped bollards solidly with concrete and allow concrete to cure seven days before installing.
 - 1. Do not fill removable bollards with concrete.
- B. Anchor bollards in place with concrete footings. Center and align bollards in holes three (3) inches (75 mm) above bottom of excavation. Place concrete and vibrate or tamp for consolidation. Support and brace bollards in position until concrete has cured.
- C. Anchor internal sleeves for removable bollards in place with concrete footings. Center and align sleeves in holes three (3) inches (75 mm) above bottom of excavation. Place concrete and vibrate or tamp for consolidation. Support and brace sleeves in position until concrete has cured.
- D. Place removable bollards over internal sleeves and secure with 3/4-inch (19-mm) machine bolts and nuts. After tightening nuts, drill holes in bolts for inserting padlocks. Owner furnishes padlocks.
- E. Fill bollards solidly with concrete, mounding top surface to shed water.

1. Do not fill removable bollards with concrete.

3.4 INSTALLING BEARING AND LEVELING PLATES

- A. Clean concrete and masonry bearing surfaces of bond-reducing materials, and roughen to improve bond to surfaces. Clean bottom surface of plates.
- B. Set bearing and leveling plates on wedges, shims, or leveling nuts. After bearing members have been positioned and plumbed, tighten anchor bolts. Do not remove wedges or shims but, if protruding, cut off flush with edge of bearing plate before packing with non-shrink grout. Pack grout solidly between bearing surfaces and plates to ensure that no voids remain.

3.5 ADJUSTING AND CLEANING

- A. Touchup Painting: Immediately after erection, clean field welds, bolted connections, and abraded areas. Paint uncoated and abraded areas with the same material as used for shop painting to comply with SSPC-PA 1 for touching up shop-painted surfaces.
 1. Apply by brush or spray to provide a minimum 2.0-mil (0.05-mm) dry film thickness.

END OF SECTION 055000

SECTION 055213 - PIPE AND TUBE RAILINGS

PART 1 - GENERAL

1.1 RELATED DOCUMENTS

- A. Drawings and general provisions of the Contract, including General and Supplementary Conditions and Division 01 Specification Sections, apply to this Section.

1.2 SUMMARY

A. Section Includes:

1. Steel pipe and tube railings.
2. Steel pipe handrails.
3. Wire mesh guardrail infill.

B. Related Requirements:

1. Section 055000 "Metal Fabrications" for miscellaneous framing and anchoring associated with pipe and tube railings.

1.3 COORDINATION

- A. Coordinate installation of anchorages for railings. Furnish setting drawings, templates, and directions for installing anchorages, including sleeves, concrete inserts, anchor bolts, and items with integral anchors, that are to be embedded in concrete or masonry. Deliver such items to Project site in time for installation.
- B. Schedule installation so wall attachments are made only to completed walls. Do not support railings temporarily by any means that do not satisfy structural performance requirements.

1.4 ACTION SUBMITTALS

A. Product Data: For the following:

1. Metals.
2. Brackets.
3. Grout, anchoring cement, and finishes.

B. Shop Drawings: Include plans, elevations, sections, details, and attachments to other work.

C. Samples: For each type of exposed finish required.

1. Sections of each distinctly different linear railing member, including handrails, top rails, posts, and woven wire mesh.
2. Fittings and brackets.
3. Assembled Sample of railing system, made from full-size components, including top rail, post, handrail, and infill. Minimum mock-up size two feet by two feet.
 - a. Show method of connecting and finishing members at intersections.

1.5 INFORMATIONAL SUBMITTALS

- A. Qualification Data: For testing agency.
- B. Welding certificates.
- C. Product Test Reports: For pipe and tube railings, for tests performed by a qualified testing agency, according to ASTM E 894 and ASTM E 935.
- D. Evaluation Reports: For post-installed anchors, from ICC-ES.

1.6 QUALITY ASSURANCE

- A. Welding Qualifications: Qualify procedures and personnel according to the following:
 - 1. AWS D1.1/D1.1M, "Structural Welding Code - Steel."
 - 2. AWS D1.6/D1.6M, "Structural Welding Code - Stainless Steel."

1.7 DELIVERY, STORAGE, AND HANDLING

- A. Protect mechanical finishes on exposed surfaces from damage by applying a strippable, temporary protective covering before shipping.

1.8 FIELD CONDITIONS

- A. Field Measurements: Verify actual locations of walls and other construction contiguous with metal fabrications by field measurements before fabrication.

PART 2 - PRODUCTS

2.1 FABRICATION

- A. Steel Pipe and Tube Railings:
 - 1. Fabricators: Subject to compliance with requirements, fabricate and provide materials as indicated. Fabrication to be by certified AISC, and has a minimum of 5 years' experience fabricating and installing steel and pipe tube railings.
- B. Source Limitations: Obtain each type of railing from single source from single manufacturer or fabricator.

2.2 PERFORMANCE REQUIREMENTS

- A. Structural Performance: Railings, including attachment to building construction, shall withstand the effects of gravity loads and the following loads and stresses within limits and under conditions indicated:
 - 1. Handrails and Top Rails of Guards:
 - a. Uniform load of 50 lbf/ ft. (0.73 kN/m) applied in any direction.
 - b. Concentrated load of 200 lbf (0.89 kN) applied in any direction.
 - c. Uniform and concentrated loads need not be assumed to act concurrently.

- 2. Infill of Guards:
 - a. Concentrated load of 50 lbf (0.22 kN) applied horizontally on an area of one (1) sq. ft. (0.093 sq. m).
 - b. Infill load and other loads need not be assumed to act concurrently.
- B. Thermal Movements: Allow for thermal movements from ambient and surface temperature changes.
 - 1. Temperature Change: 120 deg. F (67 deg. C), ambient; 180 deg. F (100 deg. C, material surfaces).
- 2.3 METALS, GENERAL
 - A. Metal Surfaces, General: Provide materials with smooth surfaces, without seam marks, roller marks, rolled trade names, stains, discolorations, or blemishes.
 - B. Brackets, Flanges, and Anchors: Formed metal of same type of material and finish as supported rails unless otherwise indicated.
 - 1. Provide type of bracket with flange tapped for concealed anchorage to threaded hanger bolt and that provides 1-1/2-inch (38-mm) clearance from inside face of handrail to finished wall surface.
- 2.4 STEEL AND IRON
 - A. Tubing: ASTM A 500 (cold formed) or ASTM A 513.
 - B. Pipe: ASTM A 53/A 53M, Type F or Type S, Grade A, Standard Weight (Schedule 40), unless another grade and weight are required by structural loads.
 - C. Plates, Shapes, and Bars: ASTM A 36/A 36M.
- 2.5 WIRE MESH INFILL
 - A. General: Provide steel wire mesh panels for infill at existing steel guard railing per details and requirements on Civil / Landscape Drawings.
- 2.6 FASTENERS
 - A. General: Provide the following:
 - 1. Ungalvanized-Steel Railings: Plated steel fasteners complying with ASTM B 633 or ASTM F 1941 (ASTM F 1941M), Class Fe/Zn 5 for zinc coating.
 - 2. Provide exposed fasteners with finish matching appearance, including color and texture, of railings.
 - B. Fasteners for Anchoring Railings to Other Construction: Select fasteners of type, grade, and class required to produce connections suitable for anchoring railings to other types of construction indicated and capable of withstanding design loads.

- C. Fasteners for Interconnecting Railing Components:
 - 1. Provide concealed fasteners for interconnecting railing components and for attaching them to other work, unless exposed fasteners are unavoidable or are the standard fastening method for railings indicated.
 - 2. Provide square or hex socket flat-head machine screws for exposed fasteners unless otherwise indicated.
- D. Post-Installed Anchors: Chemical anchors capable of sustaining, without failure, a load equal to six (6) times the load imposed when installed in unit masonry and four (4) times the load imposed when installed in concrete, as determined by testing according to ASTM E 488/E 488M, conducted by a qualified independent testing agency.
 - 1. Material: Alloy Group (1) A1 or Group (2) A4 stainless-steel bolts, ASTM F 593 (ASTM F 738M), and nuts, ASTM F 594 (ASTM F 836M).

2.7 MISCELLANEOUS MATERIALS

- A. Welding Rods and Bare Electrodes: Select according to AWS specifications for metal alloy welded.
 - 1. For stainless steel railings, provide type and alloy as recommended by producer of metal to be welded and as required for color match, strength, and compatibility in fabricated items.
- B. Primers: Provide primers that comply with Section 099123 "Interior Painting".
- C. Nonshrink, Nonmetallic Grout: Factory-packaged, nonstaining, noncorrosive, nongaseous grout complying with ASTM C 1107/C 1107M. Provide grout specifically recommended by manufacturer for interior and exterior applications.
- D. Anchoring Cement: Factory-packaged, nonshrink, nonstaining, hydraulic-controlled expansion cement formulation for mixing with water at Project site to create pourable anchoring, patching, and grouting compound.
 - 1. Water-Resistant Product: Provide formulation that is resistant to erosion from water exposure without needing protection by a sealer or waterproof coating and that is recommended by manufacturer for exterior use.

2.8 FABRICATION

- A. General: Fabricate railings to comply with requirements indicated for design, dimensions, member sizes and spacing, details, finish, and anchorage, but not less than that required to support structural loads.
- B. Shop assemble railings to greatest extent possible to minimize field splicing and assembly. Disassemble units only as necessary for shipping and handling limitations. Clearly mark units for reassembly and coordinated installation. Use connections that maintain structural value of joined pieces.

- C. Cut, drill, and punch metals cleanly and accurately. Remove burrs and ease edges to a radius of approximately 1/32 inch (1 mm) unless otherwise indicated. Remove sharp or rough areas on exposed surfaces.
- D. Form work true to line and level with accurate angles and surfaces.
- E. Fabricate connections that are exposed to weather in a manner that excludes water. Provide weep holes where water may accumulate.
- F. Cut, reinforce, drill, and tap as indicated to receive finish hardware, screws, and similar items.
- G. Connections: Fabricate railings with welded connections unless otherwise indicated.
- H. Welded Connections: Cope components at connections to provide close fit, or use fittings designed for this purpose. Weld all around at connections, including at fittings.
 - 1. Use materials and methods that minimize distortion and develop strength and corrosion resistance of base metals.
 - 2. Obtain fusion without undercut or overlap.
 - 3. Remove flux immediately.
 - 4. At exposed connections, finish exposed surfaces smooth and blended so no roughness shows after finishing and welded surface matches contours of adjoining surfaces.
- I. Nonwelded Connections: Connect members with concealed mechanical fasteners and fittings. Fabricate members and fittings to produce flush, smooth, rigid, hairline joints.
 - 1. Fabricate splice joints for field connection using an epoxy structural adhesive if this is manufacturer's standard splicing method.
- J. Form Changes in Direction as Follows:
 - 1. As detailed.
 - 2. By radius bends of radius indicated or required to meet dimensions indicated.
- K. For changes in direction made by bending, use jigs to produce uniform curvature for each repetitive configuration required. Maintain cross section of member throughout entire bend without buckling, twisting, cracking, or otherwise deforming exposed surfaces of components.
- L. Close exposed ends of railing members with prefabricated end fittings.
- M. Provide wall returns at ends of wall-mounted handrails unless otherwise indicated. Close ends of returns unless clearance between end of rail and wall is 1/4-inch (6 mm) or less.
- N. Brackets, Flanges, Fittings, and Anchors: Provide wall brackets, flanges, miscellaneous fittings, and anchors to interconnect railing members to other work unless otherwise indicated.
 - 1. At brackets and fittings fastened to plaster or gypsum board partitions, provide crush-resistant fillers or other means to transfer loads through wall finishes to structural supports and prevent bracket or fitting rotation and crushing of substrate.

- O. Provide inserts and other anchorage devices for connecting railings to concrete or masonry work. Fabricate anchorage devices capable of withstanding loads imposed by railings. Coordinate anchorage devices with supporting structure.
- P. For railing posts set in concrete, provide steel sleeves not less than twenty-four (24) inches (600 mm) long with inside dimensions not less than 1/2-inch (13 mm) greater than outside dimensions of post, with metal plate forming bottom closure.

2.9 STEEL AND IRON FINISHES

- A. For nongalvanized-steel railings, provide nongalvanized ferrous-metal fittings, brackets, fasteners, and sleeves; however, galvanize anchors to be embedded in exterior concrete or masonry.
- B. Preparation for Shop Priming: Prepare uncoated ferrous-metal surfaces to comply with requirements indicated below:
 - 1. Railings: SSPC-SP 6/NACE No. 3, "Commercial Blast Cleaning."
 - 2. Railings Indicated to Receive Primers Specified in Section 099600 "High-Performance Coatings": SSPC-SP 6/NACE No. 3, "Commercial Blast Cleaning."
 - 3. Other Railings: SSPC-SP 3, "Power Tool Cleaning."
- C. Primer Application: Apply shop primer to prepared surfaces of railings unless otherwise indicated. Comply with requirements in SSPC-PA 1, "Shop, Field, and Maintenance Painting of Steel," for shop painting. Primer need not be applied to surfaces to be embedded in concrete or masonry.
- D. Shop-Painted Finish: Comply with Section 099123 "Interior Painting." Shop paint all guardrail sections and wire mesh.
 - 1. Color: As selected by Architect from manufacturer's full range.

PART 3 - EXECUTION

3.1 EXAMINATION

- A. Examine plaster and gypsum board assemblies, where reinforced to receive anchors, to verify that locations of concealed reinforcements are clearly marked for Installer. Locate reinforcements and mark locations if not already done.

3.2 INSTALLATION, GENERAL

- A. Fit exposed connections together to form tight, hairline joints.
- B. Perform cutting, drilling, and fitting required for installing railings. Set railings accurately in location, alignment, and elevation; measured from established lines and levels and free of rack.
 - 1. Do not weld, cut, or abrade surfaces of railing components that are coated or finished after fabrication and that are intended for field connection by mechanical or other means without further cutting or fitting.
 - 2. Set posts plumb within a tolerance of 1/16-inch in three (3) feet (2 mm in 1 m).

3. Align rails so variations from level for horizontal members and variations from parallel with rake of steps and ramps for sloping members do not exceed 1/4-inch in twelve (12) feet (6 mm in 3.5 m).
- C. Control of Corrosion: Prevent galvanic action and other forms of corrosion by insulating metals and other materials from direct contact with incompatible materials.
 1. Coat, with a heavy coat of bituminous paint, concealed surfaces of aluminum that are in contact with grout, concrete, masonry, wood, or dissimilar metals.
- D. Adjust railings before anchoring to ensure matching alignment at abutting joints.
- E. Fastening to In-Place Construction: Use anchorage devices and fasteners where necessary for securing railings and for properly transferring loads to in-place construction.

3.3 RAILING CONNECTIONS

- A. Nonwelded Connections: Use mechanical or adhesive joints for permanently connecting railing components. Seal recessed holes of exposed locking screws using plastic cement filler colored to match finish of railings.
- B. Welded Connections: Use fully welded joints for permanently connecting railing components. Comply with requirements for welded connections in "Fabrication" Article whether welding is performed in the shop or in the field.
- C. Expansion Joints: Install expansion joints at locations indicated but not farther apart than required to accommodate thermal movement. Provide slip-joint internal sleeve extending two (2) inches (50 mm) beyond joint on either side, fasten internal sleeve securely to one side, and locate joint within six (6) inches (150 mm) of post.

3.4 ANCHORING POSTS

- A. Use metal sleeves preset and anchored into concrete for installing posts. After posts are inserted into sleeves, fill annular space between post and sleeve with anchoring cement, mixed and placed to comply with anchoring material manufacturer's written instructions.
- B. Leave anchorage joint exposed with anchoring material flush with adjacent surface.
- C. Anchor posts to metal surfaces with flanges, angle type, or floor type as required by conditions, connected to posts and to metal supporting members as follows:
 1. For steel pipe railings, weld flanges to post and bolt to metal supporting surfaces.
- D. Install removable railing sections, where indicated, in slip-fit metal sockets cast in concrete.

3.5 ATTACHING RAILINGS

- A. Anchor railing ends at walls with flanges anchored to wall construction and welded to railing ends.
- B. Attach railings to wall with wall brackets, except where end flanges are used. Locate brackets as indicated or, if not indicated, at spacing required to support structural loads.

- C. Attach stainless steel handrails to guardrail assembly with hidden fasteners, at interior stair assemblies.
- D. Secure wall brackets and railing end flanges to building construction as follows:
 - 1. For concrete and solid masonry anchorage, use drilled-in expansion shields and hanger or lag bolts.
 - 2. For hollow masonry anchorage, use toggle bolts.
 - 3. For steel-framed partitions, use self-tapping screws fastened to steel framing or to concealed steel reinforcements.

3.6 ADJUSTING AND CLEANING

- A. Clean by washing thoroughly with clean water and soap and rinsing with clean water.
- B. Touchup Priming and Painting: Cleaning and touchup painting of field welds, bolted connections, and abraded areas of shop paint are specified in Section 099123 "Interior Painting."

3.7 PROTECTION

- A. Protect finishes of railings from damage during construction period with temporary protective coverings approved by railing manufacturer. Remove protective coverings at time of Substantial Completion.

END OF SECTION 055213

SECTION 061000 - ROUGH CARPENTRY

PART 1 - GENERAL

1.1 RELATED DOCUMENTS

- A. Drawings and general provisions of the Contract, including General and Supplementary Conditions and Division 01 Specification Sections, apply to this Section.

1.2 SUMMARY

- A. This Section includes the following:
 - 1. Dimensional lumber.
 - 2. Wood blocking, backing, plates, and nailers.
 - 3. Preservative treated lumber.
 - 4. Engineered wood products.
 - 5. Fasteners and hangers.

1.3 DEFINITIONS

- A. Dimension Lumber: Lumber of 2 inches nominal (38 mm actual) or greater but less than 5 inches nominal (114 mm actual) in least dimension.
- B. Lumber grading agencies, and the abbreviations used to reference them, include the following:
 - 1. WWPA: Western Wood Products Association.

1.4 SUBMITTALS

- A. Product Data: For each type of process and factory-fabricated product. Indicate component materials and dimensions and include construction and application details.
 - 1. Include data for wood-preservative treatment from chemical treatment manufacturer and certification by treating plant that treated materials comply with requirements. Indicate type of preservative used and net amount of preservative retained.
 - 2. Product information and structural property data for engineered wood products and structural data and shop drawings for engineered joists (roof trusses) prepared, stamped, and signed by licensed Idaho professional engineer.
- B. Research/Evaluation Reports: For the following, showing compliance with building code in effect for Project:
 - 1. Wood-preservative treated wood.
 - 2. Engineered wood products with allowable design load information.

1.5 DELIVERY, STORAGE, AND HANDLING

- A. Stack lumber flat with spacers between each bundle to provide air circulation. Provide for air circulation around stacks and under coverings.

PART 2 - PRODUCTS

2.1 WOOD PRODUCTS, GENERAL

- A. Lumber: DOC PS 20 and applicable rules of grading agencies indicated. If no grading agency is indicated, provide lumber that complies with the applicable rules of any rules-writing agency certified by the ALSC Board of Review. Provide lumber graded by an agency certified by the ALSC Board of Review to inspect and grade lumber under the rules indicated.
 - 1. Factory mark each piece of lumber with grade stamp of grading agency.
 - 2. Where nominal sizes are indicated, provide actual sizes required by DOC PS 20 for moisture content specified. Where actual sizes are indicated, they are minimum dressed sizes for dry lumber.
 - 3. Provide dressed lumber, S4S, unless otherwise indicated.

- B. Engineered Wood Products: Provide engineered wood products acceptable to authorities having jurisdiction and for which current model code research or evaluation reports exist that show compliance with building code in effect for Project.
 - 1. Allowable Design Stresses: Provide engineered wood products with allowable design stresses, as published by manufacturer, that meet or exceed those indicated. Manufacturer's published values shall be determined from empirical data or by rational engineering analysis and demonstrated by comprehensive testing performed by a qualified independent testing agency.
 - 2. Engineered wood products shall be as specified herein, of types and sizes specified in Structural Notes and per notes and details on Drawings.

2.2 WOOD-PRESERVATIVE-TREATED LUMBER

- A. Preservative Treatment by Pressure Process: American Wood Preservers' Association (AWPA) AWPA C2.
 - 1. Preservative Chemicals: Acceptable to authorities having jurisdiction and containing no arsenic or chromium.

- B. Kiln-dry lumber after treatment to a maximum moisture content of 19 percent. Do not use material that is warped or does not comply with requirements for untreated material.

- C. Mark lumber with treatment quality mark of an inspection agency approved by the American Lumber Standards Committee (ALSC) Board of Review.

- D. Application: Treat items indicated on Drawings as “WPT.”

2.3 PRESERVATIVE WOOD TREATMENT BY PRESSURE PROCESS

- A. General: Where lumber is indicated as preservative-treated wood or is specified herein to be treated, comply with applicable requirements of AWWA Standards C2 (Lumber). Mark each treated item with the AWPB or SPIB Quality Mark Requirements.
- B. Pressure-treat above-ground items with water-borne preservatives to a minimum retention of 0.25 pcf. For interior uses, after treatment, kiln-dry lumber to a maximum moisture content of 19 percent. Treat indicated items.
 - 1. All wood members in direct contact with concrete or masonry shall be pressure treated as specified herein.

2.4 DIMENSION LUMBER

- A. For light framing (non-structural, 2” to 4” thick, 2 to 8” wide) including non-load bearing studs, blocking, curbs, etc.
 - 1. No. 2 and better
 - a. Douglas Fir and Douglas Fir-Larch graded under WWPA or WCLIB rules.
- B. For structural light framing and structural framing (2” to 4” thick, 2” and wider) including joists, load bearing studs, plates, ledgers, lintels, beams, etc.
 - 1. No. 2 and better
 - a. Douglas Fir and Douglas Fir-Larch graded under WWPA or WCLIB rules.
- C. Moisture content following kiln drying shall not exceed 19 percent.

2.5 MISCELLANEOUS LUMBER

- A. General: Provide miscellaneous lumber indicated and lumber for support or attachment of other construction, including the following:
 - 1. Blocking.
 - 2. Backing.
 - 3. Nailers.
- B. For items of dimension lumber size, provide No. 2 grade or better lumber with 19 percent maximum moisture content and the following species:
 - 1. Douglas Fir or Douglas Fir-Larch; WWPA.
- C. For blocking and nailers used for attachment of other construction, select and cut lumber to eliminate knots and other defects that will interfere with attachment of other work.

2.6 FASTENERS

- A. General: Provide fasteners of size and type indicated that comply with requirements specified in this Article for material and manufacture.
 - 1. Where rough carpentry is exposed to weather, in ground contact, pressure-preservative treated, or in area of high relative humidity, provide fasteners with hot-dip zinc coating complying with ASTM A 153/A 153M.
- B. Nails, Brads, and Staples: ASTM F 1667.
- C. Power-Driven Fasteners: NES NER-272.
- D. Wood Screws: The American Society of Mechanical Engineers International (ASME) ASME B18.6.1.
- E. Lag Bolts: ASME B18.2.1 (ASME B18.2.3.8M).
- F. Bolts: Steel bolts complying with ASTM A 307, Grade A (ASTM F 568M, Property Class 4.6); with ASTM A 563 (ASTM A 563M) hex nuts and, where indicated, flat washers.
- G. Expansion Anchors: Anchor bolt and sleeve assembly of material indicated below with capability to sustain, without failure, a load equal to 6 times the load imposed when installed in unit masonry assemblies and equal to 4 times the load imposed when installed in concrete as determined by testing per ASTM E 488 conducted by a qualified independent testing and inspecting agency.
 - 1. Material: Carbon-steel components, zinc plated to comply with ASTM B 633, Class Fe/Zn 5.
 - 2. Material: Stainless steel with bolts and nuts complying with ASTM F 593 and ASTM F 594, Alloy Group 1 or 2 (ASTM F 738M and ASTM F 836M, Grade A1 or A4).
- H. Fastening Requirements: Fastener types, sizes, and spacings shall be as specified on Drawings and per requirements of the 2018 International Building Code.

2.7 METAL FRAMING ANCHORS

- A. Basis-of-Design Products: Subject to compliance with requirements, provide metal framing anchor and hanger products indicated on Drawings by the following:
 - 1. Simpson Strong-Tie Co., Inc.

Equivalent products to those specified require architect / engineer review and approval prior to Bid.
- B. Allowable Design Loads: Provide products with allowable design loads, as published by manufacturer, that meet or exceed those of basis-of-design products. Manufacturer's published values shall be determined from empirical data or by rational engineering analysis and demonstrated by comprehensive testing performed by a qualified independent testing agency.

- C. Galvanized Steel Sheet: Hot-dip, zinc-coated steel sheet complying with ASTM A 653/A 653M, G60 (Z180) coating designation.

2.8 ENGINEERED WOOD PRODUCTS (JOISTS)

- A. General: Provide engineered wood products for which current model code evaluation / research reports exist that are acceptable to authorities having jurisdiction and that evidence compliance for the application indicated with specified requirements and the building code in effect for this Project.
- B. Engineered Web I-Joists: Composite joist members fabricated with laminated lumber top and bottom parallel chords and O.S.B. webs. Truss-Joist Corporation or equivalent product. Series and depths as noted on Drawings.
- C. Laminated Veneer Lumber (LVL):
 - 1. LVL products shall be Micro-Lam 1.9E by Truss-Joist Corporation, Versa-Lam 2.0E by Boise Cascade Corporation, RedLam 2.0E by RedBuilt, SolidStart LVL 2.0E by LP Corporation or RigidLam 2.0E by Roseburg or an approved equal.

2.9 MISCELLANEOUS MATERIALS

- A. Sill Sealer Gaskets: Glass fiber resilient insulation fabricated in strip form for use as a sill sealer; 1 inch nominal thickness compressible to 1/32 inch; selected from manufacturer's standard widths to suit width of sill members indicated; in rolls of 50 feet or 100 feet in length. (For use at all exterior wall sill plates).

PART 3 - EXECUTION

3.1 INSTALLATION, GENERAL

- A. Set rough carpentry to required levels and lines, with members plumb, true to line, cut, and fitted. Fit rough carpentry to other construction; scribe and cope as needed for accurate fit. Locate blocking, backing, plates, nailers and similar supports to comply with requirements for attaching other construction.
- B. Metal Framing Anchors: Install metal framing to comply with manufacturer's written instructions.
- C. Provide blocking, backing, plates, and nailers as indicated and as required to support facing materials, cabinetry, fixtures, visual display boards and other specialty items, trim, doorstops, and other items as indicated.
- D. Sort and select lumber so that natural characteristics will not interfere with installation or with fastening other materials to lumber. Do not use materials with defects that interfere with function of member or pieces that are too small to use with minimum number of joints or optimum joint arrangement.

- E. Comply with AWP A M4 for applying field treatment to cut surfaces of preservative-treated lumber.
 - 1. Use copper naphthenate.
- F. Securely attach rough carpentry work to substrate by anchoring and fastening as indicated on Drawings and as required by the 2018 edition of the IBC.

3.2 WOOD GROUNDS, NAILERS, BLOCKING, AND SLEEPERS

- A. Install wood grounds, nailers, blocking, and sleepers where shown and where required for screeding or attachment of other work. Form to shapes as shown and cut as required for true line and level of work to be attached. Coordinate location with other work involved.
- B. Attach to substrates as required to support applied loading. Countersink bolts and nuts flush with surfaces, where indicated. Provide washers at all nuts.
- C. Preservative treated sill plates shall be free of waness exceeding ½ inch measured perpendicular to length of plate. Install over sill sealer gasket at all building perimeter walls.

3.3 WOOD FURRING

- A. Install plumb and level with closure strips at edges and openings. Shim with wood as required for tolerance of finished work.
 - 1. Firestop furred spaces on walls at each floor level and at ceiling line with wood blocking or noncombustible materials, accurately fitted to close furred spaces.

3.4 WOOD FRAMING, GENERAL

- A. Framing Standard: Comply with N.F.P.A. "Manual for Wood Frame Construction," and with all applicable provisions of the International Building Code, 2018 Edition, Chapter 23.
- B. Install framing members of size and spacing indicated.
- C. Anchor and nail as shown, and to comply with the most restrictive provisions of the following:
 - 1. National Evaluation Report No. NER-272 for pneumatic or mechanical driven staples, P-Nails, and allied fasteners.
 - 2. Table 2304.9.1 of the International Building Code, 2018 Edition.
 - 3. Published requirements of manufacturers of engineered framing members, proprietary sheathing products, and metal framing anchors.
- D. Framing with Engineered Wood Products: Install engineered joist products in compliance with manufacturer's instructions.

- E. Do not splice structural members between supports.
- F. Firestop concealed spaces of wood framed walls and partitions at spacing not to exceed 8'-0" o.c. vertically. Where firestops are not automatically provided by the framing system used, use closely fitted wood blocks of nominal 2-inch-thick lumber of the same width as framing members.

3.5. STUD FRAMING

- A. General: Arrange studs so that wide face of stud is perpendicular to direction of wall or partition and narrow face is parallel. Install single bottom plate and double top plates using 2-inch-thick members whose widths equal that of studs. Set exterior wall sill plates on sill sealer gasket. Nail or anchor plates to supporting construction.
- B. Construct corners and intersections with not less than 3 studs. Install miscellaneous blocking and framing as shown and as required for support of facing materials, fixtures, specialty items, and trim.
 - 1. Install continuous horizontal blocking row at each 8-foot level in partitions over 8 feet high using nominal 2-inch thick members of same width as wall or partitions.
- C. Frame openings with multiple studs and headers per notes and details on Drawings. Install nailed header members of thickness equal to width of studs, provide furring, or provide full width horizontal member on top and bottom of narrower header member. Set headers on edge and support on jamb studs.
 - 1. For nonbearing partitions, install double-jamb studs and box headers per Drawings, but not less than 3 ½ inch deep vertical box header members for openings 4 feet and less in width, and not less than 5 ½ inches deep vertical box header members for wider openings.
 - 2. For load-bearing partitions, install per notes and requirements on Drawings but not less than double-jamb studs for openings 4 feet and less in width, and triple-jamb studs for wider openings. Install headers of type and depth shown or noted on Drawings.

END OF SECTION 061000

THIS PAGE INTENTIONALLY BLANK

SECTION 061600 - SHEATHING

PART 1 - GENERAL

1.1 RELATED DOCUMENTS

- A. Drawings and general provisions of the Contract, including Division 01 Specification Sections, apply to this Section.

1.2 SUMMARY

- A. This Section includes the following:
 - 1. Wall sheathing.
 - 2. Floor sheathing.
 - 3. Roof sheathing.
 - 4. Miscellaneous sheathing
 - 5. Fasteners

1.3 SUBMITTALS

- A. Product Data: For each type of sheathing and factory-fabricated product. Indicate component materials and dimensions and include construction and application details.
 - 1. Include data for wood-preservative treatment, if required, from chemical treatment manufacturer and certification by treating plant that treated plywood complies with requirements. Indicate type of preservative used and net amount of preservative retained.
 - 2. For products receiving a waterborne treatment, include statement that moisture content of treated materials was reduced to levels specified before shipment to Project site.
 - 3. Include copies of warranties from chemical treatment manufacturers for each type of treatment.
- B. Shop Drawings: Provide drawings indicating locations and spacing of Tectum planks and purlins.

1.4 DELIVERY, STORAGE, AND HANDLING

- A. Stack plywood and other panels flat with spacers between each bundle to provide air circulation. Provide for air circulation around stacks and under coverings.
- B. During the construction period, provide means for adequate distribution of concentrated loads so that the carrying capacity of any component is not exceeded.

PART 2 - PRODUCTS

2.1 WOOD PANEL PRODUCTS, GENERAL

- A. Plywood: DOC PS 1.
- B. Oriented Strand Board: DOC PS 2.
- C. Thickness: As needed to comply with requirements specified, but not less than thickness indicated.
- D. Factory mark panels to indicate compliance with applicable standard.

2.2 WALL SHEATHING

- A. OSB Wall Sheathing: Exposure 1, APA Rated.
 - 1. Span Rating: Not less than 24/16.
 - 2. Actual Thickness: Not less than 7/16”.
 - 3. Edge Condition: Square.
- B. Gypsum Sheathing: ASTM C79.
 - 1. Type: Type “X”.
 - 2. Edges: Square.
 - 3. Thickness: 5/8 inch.

2.3 FLOOR SHEATHING

- A. OSB Floor Sheathing: Exposure 1, APA Rated.
 - 1. Span Rating: Not less than 24/16.
 - 2. Actual Thickness: Not less than 23/32”.
 - 3. Edge Condition: Tongue and Groove.

2.3 ROOF SHEATHING

- A. OSB Roof Sheathing: Exposure 1, APA Rated.
 - 1. Span Rating: Not less than 40/20.
 - 2. Actual Thickness: Not less than 19/32”
 - 3. Edge Condition: Tongue and Groove

2.4 MISCELLANEOUS SHEATHING

- A. Oriented – Strand Board, Exposure 1, at concealed locations or plywood, DOC PS 1, Exposure 1, Grade B-D, fire retardant treated if indicated.

2.5 FASTENERS

- A. General: Provide fasteners of size and type indicated that comply with requirements specified in this Article for material and manufacture.
 - 1. For roof and wall sheathing, provide fasteners with hot-dip zinc coating complying with ASTM A 153/A 153M or of Type 304 stainless steel.
- B. Nails, Brads, and Staples: ASTM F 1667.
- C. Power-Driven Fasteners: NES NER-272.
- D. Wood Screws: ASME B18.6.1.

PART 3 - EXECUTION

3.1 INSTALLATION, GENERAL

- A. Do not use materials with defects that impair quality of sheathing or pieces that are too small to use with minimum number of joints or optimum joint arrangement.
- B. Cut panels at penetrations, edges, and other obstructions of work; fit tightly against abutting construction, unless otherwise indicated.
- C. Securely attach to substrate by fastening as indicated on Drawings and complying with the following:
 - 1. NES NER-272 for power-driven fasteners.
 - 2. Table 2304.9.1, "Fastening Schedule," 2018 "International Building Code."
- D. Use common wire nails, unless otherwise indicated. Select fasteners of size that will not fully penetrate members where opposite side will be exposed to view or will receive finish materials. Make tight connections. Install fasteners without splitting wood.
- E. Coordinate wall and roof sheathing installation with flashing and joint-sealant installation so these materials are installed in sequence and manner that prevent exterior moisture from passing through completed assembly.
- F. Do not bridge building expansion joints; cut and space edges of panels to match spacing of structural support elements.
- G. Coordinate sheathing installation with installation of materials installed over sheathing so sheathing is not exposed to precipitation or left exposed at end of the workday when rain is forecast.

3.2 WOOD STRUCTURAL PANEL INSTALLATION

- A. General: Comply with applicable recommendations in APA Form No. E30S, "Engineered Wood Construction Guide," for types of structural-use panels and applications indicated.

- B. Wood Sheathing Attachment Schedule: wall and roof sheathing shall be attached as per the following schedule and per the requirements of the structural drawings:

<u>Location</u>	<u>Application / Attachment</u>
7/16" OSB wall sheathing	Apply panels parallel to wall framing. Joints shall center on studs. Attach with 10d nails at 6" o.c. edges and 12" o.c. field unless noted otherwise. See Structural Notes for additional information.
19/32" OSB roof sheathing	Apply panels perpendicular to roof framing members. Offset end joints 48" in adjacent rows. Joints between adjacent panels shall occur centered on framing members. Attach with 10d common nails at 6" o.c. at panel edges and 12" o.c. field at all supports. See Structural Notes for additional information.
23/32" OSB floor sheathing	Apply panels perpendicular to floor framing members. Joints between adjacent panels shall occur centered on framing members. Glue and attach with 10d common nails at 6" o.c. at panel edges and 12" o.c. field at all supports. See Structural Notes for additional information.

END OF SECTION 061600

SECTION 061753 - SHOP-FABRICATED WOOD TRUSSES

PART 1 - GENERAL

1.1 RELATED DOCUMENTS

- A. Drawings and general provisions of the Contract, including General and Supplementary Conditions and Division 01 Specification Sections, apply to this Section.

1.2 SUMMARY

- A. This Section includes the following:
 - 1. Wood roof trusses.
 - 2. Metal truss accessories.
 - a. Miscellaneous fastening devices, except for connector plates, are specified elsewhere.
- B. Related Sections include the following:
 - 1. Division 06 Section "Sheathing" for roof deck sheathing.

1.3 DEFINITIONS

- A. Metal-Plate-Connected Wood Trusses: Planar structural units consisting of metal-plate-connected members fabricated from dimension lumber and cut and assembled before delivery to Project site.
- B. TPI: Truss Plate Institute, Inc.
- C. Lumber grading agencies, and the abbreviations used to reference them, include the following:
 - 1. NeLMA: Northeastern Lumber Manufacturers' Association.
 - 2. NLGA: National Lumber Grades Authority.
 - 3. SPIB: The Southern Pine Inspection Bureau.
 - 4. WCLIB: West Coast Lumber Inspection Bureau.
 - 5. WWPA: Western Wood Products Association.

1.4 PERFORMANCE REQUIREMENTS

- A. Structural Performance: Provide metal-plate-connected wood trusses capable of withstanding design loads within limits and under conditions indicated. Comply with requirements in TPI 1 unless more stringent requirements are specified below.
 - 1. Design Loads: See Drawings.

1.5 SUBMITTALS

- A. Product Data: For wood-preservative-treated lumber, fire-retardant treated lumber, (if any) metal-plate connectors, metal truss accessories, and fasteners.
 - 1. Include data for wood-preservative treatment from chemical treatment manufacturer and certification by treating plant that treated materials comply with requirements. Indicate type of preservative used and net amount of preservative retained.
 - 2. Include data for fire-retardant treatment from chemical treatment manufacturer and certification by treating plant that treated materials comply with requirements. Include physical properties of treated materials based on testing by a qualified independent testing agency.
 - 3. For fire-retardant treatments specified to be High-Temperature (HT) type, include physical properties of treated lumber both before and after exposure to elevated temperatures, based on testing by a qualified independent testing agency according to ASTM D 5664.
 - 4. For products receiving a waterborne treatment, include statement that moisture content of treated materials was reduced to levels specified before shipment to truss fabricator.
 - 5. Include copies of warranties from chemical treatment manufacturers for each type of treatment.

- B. Shop Drawings: Prepared by or under the supervision of a qualified professional engineer. Show fabrication and installation details for trusses.
 - 1. Show location, pitch, span, camber, configuration, and spacing for each type of truss required.
 - 2. Indicate sizes, stress grades, and species of lumber.
 - 3. Indicate locations of permanent bracing required to prevent buckling of individual truss members due to design loads.
 - 4. Indicate type, size, material, finish, design values, orientation, and location of metal connector plates.
 - 5. Show splice details and bearing details.
 - 6. For products indicated to comply with design loads, include drawings with structural analysis data and calculations signed and sealed by the qualified professional engineer, licensed in the State of Idaho, responsible for their preparation.

- C. Product Certificates: For metal-plate-connected wood trusses, signed by officer of truss fabricating firm.

- D. Qualification Data: For metal-plate manufacturer, professional engineer fabricator and Installer.

- E. Material Certificates: For dimension lumber specified to comply with minimum allowable unit stresses. Indicate species and grade selected for each use and design values approved by the ALSC Board of Review.

- F. Research/Evaluation Reports: For the following, showing compliance with building code in effect for Project:
 - 1. Wood-preservative-treated lumber.
 - 2. Fire-retardant-treated wood.
 - 3. Metal-plate connectors.

4. Metal truss accessories.

1.6 QUALITY ASSURANCE

- A. Metal Connector-Plate Manufacturer Qualifications: A manufacturer that is a member of TPI and that complies with quality-control procedures in TPI 1 for manufacture of connector plates.
 1. Manufacturer's responsibilities include providing professional engineering services needed to assume engineering responsibility.
 2. Engineering Responsibility: Preparation of Shop Drawings and comprehensive engineering analysis by a qualified professional engineer.
- B. Fabricator Qualifications: Shop that participates in a recognized quality-assurance program that complies with quality-control procedures in TPI 1 and that involves third-party inspection by an independent testing and inspecting agency acceptable to Architect and authorities having jurisdiction.
- C. Source Limitations for Connector Plates: Obtain metal connector plates from a single manufacturer.
- D. Comply with applicable requirements and recommendations of the following publications:
 1. TPI 1, "National Design Standard for Metal Plate Connected Wood Truss Construction."
 2. TPI DSB, "Recommended Design Specification for Temporary Bracing of Metal Plate Connected Wood Trusses."
 3. TPI HIB, "Commentary and Recommendations for Handling, Installing & Bracing Metal Plate Connected Wood Trusses."
- E. Wood Structural Design Standard: Comply with applicable requirements in AF&PA's "National Design Specifications for Wood Construction" and its "Supplement."

1.7 DELIVERY, STORAGE, AND HANDLING

- A. Handle and store trusses to comply with recommendations of TPI HIB, "Commentary and Recommendations for Handling, Installing & Bracing Metal Plate Connected Wood Trusses."
 1. Store trusses flat, off of ground, and adequately supported to prevent lateral bending.
 2. Protect trusses from weather by covering with waterproof sheeting, securely anchored.
 3. Provide for air circulation around stacks and under coverings.
 4. During the construction period, provide means for adequate distribution of concentrated loads so that the carrying capacity of any one truss or other component is not exceeded.
- B. Inspect trusses showing discoloration, corrosion, or other evidence of deterioration. Discard and replace trusses that are damaged or defective.
- C. If the trusses are to be stockpiled or stored prior to erection, set in vertical positions and rest upon temporary bearing supports and brace so they will not be subject to unusual bending or tip over.

1.8 COORDINATION

- A. Time delivery and erection of trusses to avoid extended on-site storage and to avoid delaying progress of other trades whose work must follow erection of trusses.

1.9 PROJECT CONDITIONS

- A. Field Measurements: Verify dimensions shown on Drawings by taking field measurements and checking shop drawings details before proceeding with fabrications.

1.10 SCHEDULING

- A. Time delivery and installation of trusses to avoid delaying other trades whose work is dependent on or affected by the carpentry work and to comply with protection and storage requirements.

PART 2 - PRODUCTS

2.1 DIMENSION LUMBER

- A. Lumber: DOC PS 20 and applicable rules of grading agencies indicated. If no grading agency is indicated, provide lumber that complies with the applicable rules of any rules writing agency certified by the ALSC Board of Review. Provide lumber graded by an agency certified by the ALSC Board of Review to inspect and grade lumber under the rules indicated.
 - 1. Factory mark each piece of lumber with grade stamp of grading agency.
 - 2. For exposed lumber indicated to receive a stained or natural finish, omit grade stamp and provide certificates of grade compliance issued by grading agency.
 - 3. Provide dressed lumber, S4S.
 - 4. Provide dry lumber with 19 percent maximum moisture content at time of dressing.
- B. Grade and Species: For truss chord and web members, provide dimension lumber of any species, graded visually or mechanically, and capable of supporting required loads without exceeding allowable design values according to AF&PA's "National Design Specifications for Wood Construction" and its "Supplement."
- C. Grade and Species: Provide visually graded dimension lumber for truss chord and web members, of not less than the following grade and any of the following species:
 - 1. Grade for Chord Members: Select Structural No. 2.
 - 2. Grade for Web Members: No. 2 Construction.
 - 3. Species: Douglas fir-larch; WCLIB or WWPA.
- D. Grade and Species: Provide dimension lumber of any species for truss chord and web members, graded as follows and of the following minimum design values for size of member required according to AF&PA's "National Design Specifications for Wood Construction" and its "Supplement":
 - 1. Grading Method: Visual or mechanical.

2. Design Values: As indicated on Drawings.

- E. Minimum Chord Size for Roof Trusses: 2 by 6 inches nominal (38 by 140 mm actual) for both top chords and bottom chords.
- F. Permanent Bracing: Provide wood bracing that complies with requirements for miscellaneous lumber in Division 06 Section Rough Carpentry. Miscellaneous Rough Carpentry.
- G. Fabricate trusses in accordance with approved engineering drawings.
- H. Moisture Content: The average moisture content of lumber 2 inches or less in thickness shall be 19 percent or less at time of enclosure.
- I. Lumber defects such as wane or knots occurring in the connector plate area shall not affect more than ten percent of required plate area, or number of effective teeth required for each truss member

2.2 METAL CONNECTOR PLATES

- A. Available Manufacturers: Subject to compliance with requirements, manufacturers offering products that may be incorporated into the Work include, but are not limited to, the following:
- B. Manufacturers: Subject to compliance with requirements, provide products by one of the following:
 - 1. Alpine Engineered Products, Inc.
 - 2. Cherokee Metal Products, Inc.; Masengill Machinery Company.
 - 3. CompuTrus, Inc.
 - 4. Eagle Metal Products.
 - 5. Jager Building Systems, Inc.
 - 6. MiTek Industries, Inc.; a subsidiary of Berkshire Hathaway Inc.
 - 7. Robbins Engineering, Inc.
 - 8. TEE-LOK Corporation; a subsidiary of Berkshire Hathaway Inc.
 - 9. Truswal Systems Corporation.
- C. General: Fabricate connector plates to comply with TPI 1.
- D. Hot-Dip Galvanized Steel Sheet: ASTM A 653/A 653M; Structural Steel (SS), high-strength low-alloy steel Type A (HSLAS Type A), or high-strength low-alloy steel Type B (HSLAS Type B); G60 (Z180) coating designation; and not less than 0.036 inch (0.9 mm) thick. In highly corrosive environments or when fire retardant lumber is specified, furnish stainless steel connector plates in lieu of hot dip galvanized.
 - 1. Use for interior locations where stainless steel is not indicated.

2.3 FASTENERS

- A. General: Provide fasteners of size and type indicated that comply with requirements specified in this Article for material and manufacture.

1. Where trusses are exposed to weather, in ground contact, made from pressure-preservative treated wood, or in area of high relative humidity, provide fasteners with hot-dip zinc coating complying with ASTM A 153/A 153M.
- B. Nails, Brads, and Staples: ASTM F 1667.
 - C. Power-Driven Fasteners: NES NER-272.
 - D. Wood Screws: ASME B18.6.1.
 - E. Lag Bolts: ASME B18.2.1.
 - F. Bolts: Steel bolts complying with ASTM A 307, Grade A with ASTM A 563 hex nuts and, where indicated, flat washers.
 - G. Expansion Anchors: Anchor bolt and sleeve assembly of material indicated below with capability to sustain, without failure, a load equal to 6 times the load imposed when installed in unit masonry assemblies and equal to 4 times the load imposed when installed in concrete as determined by testing per ASTM E 488 conducted by a qualified independent testing and inspecting agency.
 1. Material: Carbon-steel components, zinc plated to comply with ASTM B 633, Class Fe/Zn 5.
 2. Material: Stainless steel with bolts and nuts complying with ASTM F 593 and ASTM F 594, Alloy Group 1 or 2.

2.4 METAL TRUSS ACCESSORIES

- A. Available Manufacturers: Subject to compliance with requirements, manufacturers offering products that may be incorporated into the Work include, but are not limited to, the following:
- B. Manufacturers: Subject to compliance with requirements, provide products by one of the following:
- C. Basis-of-Design Products: Subject to compliance with requirements, provide products indicated on Drawings or comparable products by one of the following:
 1. Cleveland Steel Specialty Co.
 2. Harlen Metal Products, Inc.
 3. KC Metals Products, Inc.
 4. Simpson Strong-Tie Co., Inc.
 5. Southeastern Metals Manufacturing Co., Inc.
 6. USP Structural Connectors.
- D. Allowable Design Loads: Provide products with allowable design loads, as published by manufacturer, that meet or exceed those indicated of basis-of-design products of products of manufacturers listed. Manufacturer's published values shall be determined from empirical data or by rational engineering analysis and demonstrated by comprehensive testing performed by a qualified independent testing agency.

- E. Galvanized Steel Sheet: Hot-dip, zinc-coated steel sheet complying with ASTM A 653/A 653M, G60 (Z180) coating designation.
 - 1. Use for interior locations where stainless steel is not indicated.
- F. Truss Tie-Downs: Bent strap tie for fastening roof trusses to wall studs below, 1-1/2 inches (38 mm) wide by 0.050 inch (1.3 mm) thick. Tie fastens to one side of truss, top plates, and side of stud below.
- G. Truss Tie-Downs (Hurricane or Seismic Ties): Bent strap tie for fastening roof trusses to wall studs below, 2-1/4 inches (57 mm) wide by 0.062 inch (1.6 mm) thick. Tie fits over top of truss and fastens to both sides of truss, top plates, and one side of stud below.
- H. Truss Tie-Downs (Hurricane or Seismic Ties): Bent strap tie for fastening roof trusses to wall studs below, 2-1/2 inches (63 mm) wide by 0.062 inch (1.6 mm) thick. Tie fits over top of truss and fastens to both sides of truss, inside face of top plates, and both sides of stud below.
- I. Roof Truss Clips: Angle clips for bracing bottom chord of roof trusses at non-load-bearing walls, 1-1/4 inches (32 mm) wide by 0.050 inch (1.3 mm) thick. Clip is fastened to truss through slotted holes to allow for truss deflection.
- J. Floor Truss Hangers: U-shaped hangers, full depth of floor truss, with 1-3/4-inch- (44-mm-) long seat; formed from metal strap 0.062 inch (1.6 mm) thick with tabs bent to extend over and be fastened to supporting member.
- K. Roof Truss Bracing/Spacers: U-shaped channels, 1-1/2 inches (38 mm) wide by 1 inch (25 mm) deep by 0.040 inch (1.0 mm) thick, made to fit between 2 adjacent trusses and accurately space them apart, and with tabs having metal teeth for fastening to trusses.

2.5 MISCELLANEOUS MATERIALS

- A. Galvanizing Repair Paint: SSPC-Paint 20, with dry film containing a minimum of 94 percent zinc dust by weight.
- B. Protective Coatings: SSPC-Paint 22, epoxy-polyamide primer or SSPC-Paint 16, coal-tar epoxy-polyamide paint.

2.6 FABRICATION

- A. Cut truss members to accurate lengths, angles, and sizes to produce close-fitting joints.
- B. Fabricate metal connector plates to sizes, configurations, thicknesses, and anchorage details required to withstand design loads for types of joint designs indicated.
- C. Assemble truss members in design configuration indicated; use jigs or other means to ensure uniformity and accuracy of assembly with joints closely fitted to comply with tolerances in TPI 1. Position members to produce design camber indicated.
 - 1. Fabricate wood trusses within manufacturing tolerances in TPI 1.

- D. Connect truss members by metal connector plates located and securely embedded simultaneously in both sides of wood members by air or hydraulic press.
- E. Do not permit open joints which depend on the stiffness of the metal connector plates to transmit stresses or improperly fitting joints. Build camber into the member, as noted, by properly positioning the members in the fabricating jig.
- F. Wood members shall be accurately cut and fabricated so that members have good bearing and completed truss units are uniform. See Truss Plate Institute Quality Standard for Metal Plate Connected Wood Trusses QST-88 for tolerances and other special requirements.

PART 3 - EXECUTION

3.1 INSTALLATION

- A. Install wood trusses only after supporting construction is in place and is braced and secured.
- B. If trusses are delivered to Project site in more than one piece, assemble trusses before installing.
- C. Hoist trusses in place by lifting equipment suited to sizes and types of trusses required, exercising care not to damage truss members or joints by out-of-plane bending or other causes.
- D. Install and brace trusses according to TPI recommendations and as indicated. Erection bracing and blocking shall hold trusses straight and plumb and in safe condition until decking and permanent truss bracing has been fastened forming a structurally sound roof framing system.
- E. Install trusses plumb, square, and true to line and securely fasten to supporting construction.
 - 1. Erect members with the top and bottom chords in true vertical alignment. Align top chords of trusses parallel to each other and straight with no point in the plane on the top chords more than 3/8 inch out of true horizontal.
- F. Space trusses as indicated; adjust and align trusses in location before permanently fastening.
- G. Anchor trusses securely at bearing points; use metal truss tie-downs or floor truss hangers as applicable. Install fasteners through each fastener hole in truss accessories according to manufacturer's fastening schedules and written instructions.
- H. Securely connect each truss ply required for forming built-up girder trusses.
 - 1. Anchor trusses to girder trusses as indicated.
- I. Install and fasten permanent bracing during truss erection and before construction loads are applied. Anchor ends of permanent bracing where terminating at walls or beams.
 - 1. Install bracing to comply with Division 06 Section Rough Carpentry.
 - 2. Install and fasten strongback bracing vertically against vertical web of parallel-chord floor trusses at centers indicated.
 - 3. Permanent structural cross bracing to ensure overall rigidity of the roof system shall be in accordance with the project Structural Drawings. Check truss design drawings for additional special bracing or blocking requirements.

- J. Install wood trusses within installation tolerances in TPI 1.
- K. Bridging: Install a continuous line of 2 inches x 4 inches bridging connected to each member at the web or chord member during the erection stage. Provide one line along the top and one line along the bottom chord.
- L. Unless otherwise indicated on the Drawings, nailing shall be as required to assemble and secure wood construction, but in no case less than that required by applicable building codes. Connectors shall have current ICC approval.
- M. Do not cut or remove truss members.
- N. Replace wood trusses that are damaged or do not meet requirements.
 - 1. Do not alter trusses in field.

3.2 REPAIRS AND PROTECTION

- A. Protect wood that has been treated with inorganic boron (SBX) from weather. If, despite protection, inorganic boron-treated wood becomes wet, apply EPA-registered borate treatment. Apply borate solution by spraying to comply with EPA-registered label.
- B. Protect rough carpentry from weather. If, despite protection, rough carpentry becomes wet, apply EPA-registered borate treatment. Apply borate solution by spraying to comply with EPA-registered label.
- C. Repair damaged galvanized coatings on exposed surfaces with galvanized repair paint according to ASTM A 780 and manufacturer's written instructions.
- D. Protective Coating: Clean and prepare exposed surfaces of metal connector plates. Brush apply primer, when part of coating system, and one coat of protective coating.
 - 1. Apply materials to provide minimum dry film thickness recommended by coating system manufacturer.

END OF SECTION 061753

THIS PAGE INTENTIONALLY BLANK

SECTION 064116 – PLASTIC LAMINATE FACED ARCHITECTURAL CABINETS

PART 1 - GENERAL

1.1 RELATED DOCUMENTS

- A. Drawings and general provisions of the Contract, including General and Supplementary Conditions and Division 01 Specification Sections, apply to this Section.

1.2 SUMMARY

A. Section Includes:

1. Plastic-laminate-faced architectural cabinets.
2. Plastic-laminate countertops.
3. Miscellaneous plastic laminate covered woodwork. (Includes windowsills where shown on Drawings)
4. Wood furring, shims, and hanging strips for installing plastic-laminate-faced architectural cabinets unless concealed within other construction before cabinet installation

B. Related Requirements:

1. Section 061000 "Rough Carpentry" for in-wall wood blocking, furring, shims, and hanging strips required for installing cabinets, concealed within other construction, before cabinet installation.

1.3 PREINSTALLATION MEETINGS

- A. Preinstallation Conference: Conduct conference at Project site.

1.4 ACTION SUBMITTALS

- A. Product Data: For each type of product, including, panel products, high-pressure decorative laminate, adhesive for bonding plastic laminate, fire-retardant-treated materials, and cabinet hardware and accessories.

1. Include data for fire-retardant treatment from chemical-treatment manufacturer and certification by treating plant that treated materials comply with requirements.

- B. Shop Drawings: Show location of each item, dimensioned plans and elevations, large-scale details, attachment devices, and other components.

1. Show details full size.
2. Show locations and sizes of furring, blocking, and hanging strips, including concealed blocking and reinforcement specified in other Sections.
3. Show locations and sizes of cutouts and holes for electrical switches and outlets, and other items installed in architectural plastic-laminate cabinets.

C. Samples for Initial Selection:

1. Plastic laminates.

2. PVC edge material.
3. Thermoset decorative panels.

D. Samples for Verification:

1. Plastic laminates, 12 by 12 inches (300 by 300 mm), for each type, color, pattern, and surface finish, with one sample applied to core material, and specified edge material applied to one edge].
2. Wood-grain plastic laminates, 12 by 12 inches (600 by 600 mm), for each type, pattern and surface finish, with one sample applied to core material, and specified edge material applied to one edge.
3. Thermoset decorative panels, 12 by 12 inches (300 by 300 mm), for each color, pattern, and surface finish, with edge banding on one edge.
4. Corner pieces as follows:
 - a. Cabinet-front frame joints between stiles and rails, as well as exposed end pieces, eighteen (18) inches (450 mm) high by eighteen (18) inches (450 mm) wide by six (6) inches (150 mm) deep.
 - b. Miter joints for standing trim.
5. Exposed cabinet hardware and accessories, one unit for each type and finish.

1.5 INFORMATIONAL SUBMITTALS

- A. Qualification Data: For Installer and fabricator.
- B. Product Certificates: For the following:
 1. Composite wood products.
 2. Thermoset decorative panels.
 3. High-pressure decorative laminate.
 4. Adhesives.
- C. Woodwork Quality Standard Compliance: Compliance with the AWI (Architectural Woodwork Institute) and AWS (Architectural Woodwork Standards) are to be applied to the production and installation of all architectural wood products.
- D. Evaluation Reports: For fire-retardant-treated materials, from ICC-ES.

1.6 QUALITY ASSURANCE

- A. Fabricator Qualifications: Shop that employs skilled workers who custom fabricate products similar to those required for this Project and whose products have a record of successful in-service performance.
- B. Installer Qualifications: Woodwork Quality Standard Compliance: Compliance with the AWI (Architectural Woodwork Institute) and AWS (Architectural Woodwork Standards) are to be applied to the production and installation of all architectural wood products. AWI Certification is not required.

- C. Testing Agency Qualifications: For testing agency providing classification marking for fire-retardant-treated material, an inspection agency acceptable to authorities having jurisdiction that periodically performs inspections to verify that the material bearing the classification marking is representative of the material tested.
- D. Mockups: Build mockups to verify selections made under Sample submittals and to demonstrate aesthetic effects and set quality standards for materials and execution.
 - 1. Build mockups of typical plastic-laminate cabinets as shown on Drawings.
 - 2. Subject to compliance with requirements, approved mockups may become part of the completed Work if undisturbed at time of Substantial Completion.

1.7 DELIVERY, STORAGE, AND HANDLING

- A. Do not deliver cabinets until painting and similar operations that could damage woodwork have been completed in installation areas. If cabinets must be stored in other than installation areas, store only in areas where environmental conditions comply with requirements specified in "Field Conditions" Article.

1.8 FIELD CONDITIONS

- A. Environmental Limitations: Do not deliver or install cabinets until building is enclosed, wet work is complete, and HVAC system is operating and maintaining temperature and relative humidity at occupancy levels during the remainder of the construction period.
- B. Environmental Limitations: Do not deliver or install cabinets until building is enclosed, wet work is complete, and HVAC system is operating and maintaining temperature between 60 and 90 deg F (16 and 32 deg C) and relative humidity between 40 and 60 percent during the remainder of the construction period.
- C. Field Measurements: Where cabinets are indicated to fit to other construction, verify dimensions of other construction by field measurements before fabrication, and indicate measurements on Shop Drawings. Coordinate fabrication schedule with construction progress to avoid delaying the Work.
 - 1. Locate concealed framing, blocking, and reinforcements that support cabinets by field measurements before being enclosed, and indicate measurements on Shop Drawings.
- D. Established Dimensions: Where cabinets are indicated to fit to other construction, establish dimensions for areas where cabinets are to fit. Provide allowance for trimming at site, and coordinate construction to ensure that actual dimensions correspond to established dimensions.

1.9 COORDINATION

- A. Coordinate sizes and locations of framing, blocking, furring, reinforcements, and other related units of Work specified in other Sections to ensure that cabinets can be supported and installed as indicated.

PART 2 - PRODUCTS

2.1 PLASTIC-LAMINATE-FACED ARCHITECTURAL CABINETS

- A. Quality Standard: Unless otherwise indicated, comply with the "Architectural Woodwork Standards" for grades of architectural plastic-laminate cabinets indicated for construction, finishes, installation, and other requirements.
1. Compliance with the AWI (Architectural Woodwork Institute) and AWS (Architectural Woodwork Standards) are to be applied to the production and installation of all architectural wood products.
 2. The Contract Documents contain selections chosen from options in the quality standard and additional requirements beyond those of the quality standard. Comply with those selections and requirements in addition to the quality standard.
 3. Compliance with AWS Casework Design Series (CDS) Numbering system is required with the design and construction of the specified cabinets.
 4. Refer to AWI Standards for surface terminology.
- B. Grade: Premium.
- C. Type of Construction: Flush overlay.
- D. Cabinet, Door, and Drawer Front Interface Style: Full overlay or as indicated on drawings.
- E. High-Pressure Decorative Laminate: NEMA LD 3, grades as indicated or if not indicated, as required by woodwork quality standard.
1. Manufacturers: Subject to compliance with requirements, provide products by one of the following:
 - a. Formica Corporation.
 - b. Wilsonart.
 - c. Arborite.
 - d. Nevamar
 - e. Or approved equal.
- F. Laminate Cladding for Exposed Surfaces:
1. Horizontal Surfaces: Grade HGS.
 2. Postformed Surfaces: Grade HGP.
 3. Vertical Surfaces: Grade VGS.
 4. Edges: PVC edge banding, 0.12 inch (3mm) thick, matching laminate in color, pattern, and finish.
 5. Pattern Direction: Vertically for doors and fixed panels, horizontally for drawer fronts or as indicated.
- G. Materials for Semi-exposed Surfaces:
1. Surfaces Other Than Drawer Bodies: High-pressure decorative laminate, NEMA LD 3, Grade VGS. See drawings for locations of thermoset decorative surfacing (melamine) at cabinet interiors.

- a. Edges of Plastic-Laminate Shelves: PVC edge banding, 0.12 inch (3mm) thick, matching laminate in color, pattern, and finish.
 - b. Edges of Thermoset Decorative Panel Shelves: PVC or polyester edge banding.
- 2. Drawer Sides and Backs: Thermoset decorative panels with PVC or polyester edge banding.
- 3. Drawer Bottoms: Thermoset decorative panels.
- H. Concealed Backs of Panels with Exposed Plastic-Laminate Surfaces: High-pressure decorative laminate, NEMA LD 3, Grade BKL.
- I. Drawer Construction: Fabricate with exposed fronts fastened to subfront with mounting screws from interior of body.
 - 1. Join subfronts, backs, and sides with glued rabbeted joints supplemented by mechanical fasteners or glued dovetail joints.
- J. Colors, Patterns, and Finishes: Provide materials and products that result in colors and textures of exposed laminate surfaces complying with the following requirements:
 - 1. As selected by Architect from laminate manufacturer's full range in all categories, including wood grains with or without matte finish. Wood grain direction shall be vertical on all vertical cabinet surfaces.
- K. Materials for exposed interior surfaces:
 - a. For exposed interiors of panel with exposed plastic laminate surfaces, provide surface of high-pressure decorative laminate, NEMA LD 3, Grade VGS at locations indicated on the Drawings; otherwise, refer to 'Millwork General Notes' and Keynotes on the Drawings for cabinet construction.
 - b. Edges of Plastic-Laminate Shelves: PVC edge banding, 0.12 inch (3mm) thick, matching laminate in color, pattern, and finish.
 - c. Edges of Thermoset Decorative Panel Shelves: PVC or polyester edge banding.

2.2 PLASTIC-LAMINATE COUNTERTOPS

- A. Grade: Premium
- B. High-Pressure Decorative Laminate Grade: HGS.
- C. Colors, Patterns, and Finishes: Provide materials and products that result in colors and textures of exposed laminate surfaces complying with the following requirements:
 - 1. As selected by Architect from manufacturer's full range in one or both of the following categories:
 - a. Solid colors with core same color as surface, matte finish.

- b. Non-wood grain patterns, matte finish.
- D. Edge Treatment: Same as laminate cladding on horizontal surfaces at vertical splashes. PVC edge banding, 0.12 inch (3mm) thick, matching laminate in color, pattern, and finish, at vertical countertop edges. Provide two-inch radius at all exposed, 270 deg. outside countertop corners.
- E. Core Material: 1 1/8 inch particleboard made with water resistant exterior glue.
- F. Backer Sheet: Provide plastic-laminate backer sheet, Grade BKL, on underside of countertop substrate.

2.3 UTILITY SHELVING, OPEN AND WITHIN CABINETS

- A. Grade: Custom.
- B. Shelf Material: 3/4-inch (19-mm) thermoset decorative panel with PVC or polyester edge banding.
- C. Colors: As selected from thermoset decorative panel manufacturer's full range of selections.

2.4 WOOD MATERIALS

- A. Wood Products: Provide materials that comply with requirements of referenced quality standard for each type of woodwork and quality grade specified unless otherwise indicated.
 - 1. Wood Moisture Content: 5 to 10 percent.
- B. Composite Wood Products: Provide materials that comply with requirements of referenced quality standard for each type of woodwork and quality grade specified unless otherwise indicated.
 - 1. Medium-Density Fiberboard: ANSI A208.2, Grade 130, made with binder containing no urea formaldehyde. Moisture resistant MDF shall be utilized at all sink base locations.
 - 2. Particleboard: ANSI A208.1, Grade M-2-Exterior Glue.
 - 3. Softwood Plywood: DOC PS 1, medium-density overlay.
 - 4. Veneer-Faced Panel Products (Hardwood Plywood): HPVA HP-1, made with adhesive containing no urea formaldehyde.
 - 5. Thermoset Decorative Panels: Particleboard or medium-density fiberboard finished with thermally fused, melamine-impregnated decorative paper and complying with requirements of NEMA LD 3, Grade VGL, for test methods 3.3, 3.4, 3.6, 3.8, and 3.10.

2.5 CABINET HARDWARE AND ACCESSORIES

- A. General: Provide cabinet hardware and accessory materials associated with architectural cabinets except for items specified in Division 8 Section "Door Hardware".
- B. Frameless Concealed Hinges (European Type): BHMA A156.9, B01602, 170 degrees of opening, self-closing.
- C. Back-Mounted Pulls: BHMA A156.9, B02011. Solid metal, 4 inches long and 5/16 in diameter.

- D. Catches: Magnetic catches, BHMA A156.9, B03141. Interior double door catch to be equal to “Ives” elbow catch.
- E. Adjustable Shelf Standards and Supports (if indicated): BHMA A156.9, B04102; with shelf brackets, B04112.
- F. Shelf Rests: BHMA A156.9, B04013; metal, one pin type, with spiked or ribbed anti-slide feature. Equal to “Hafele 282.24.720.
- G. Drawer Slides: BHMA A156.9, B05091
 - 1. Heavy Duty Grade 1HD-100 and Grade HD-200: Side mounted and extending under bottom edge of drawer; full-extension; epoxy-coated steel with polymer rollers.
 - 2. For drawers, not more than three (3) inches (75 mm) high and not more than twenty-four (24) inches (600 mm) wide, provide Grade 1.
- H. Door Locks: BHMA A156.11, E07121. Pin tumbler lock. All locks within a given room shall be keyed alike. Locks in different rooms shall be keyed differently. Provide a master key for all door locks. Re-keyable pin tumbler cam locks are also approved.
- I. Drawer Locks: BHMA A156.11, E07041. Pin tumbler lock. All locks within a given room shall be keyed alike. Locks in different rooms shall be keyed differently. Provide a master key for all drawer locks. Re-keyable pin tumbler cam locks are also approved.
- J. Door and Drawer Silencers: BHMA A156.16, L03011.
- K. Exposed and concealed Hardware Finishes: For exposed hardware, provide finish that complies with BHMA A156.18 for BHMA finish number indicated.
 - 1. Satin Chromium Plated Dull: BHMA 626 (US26D).
- L. Grommets for Cable Passage through Countertops: 3-inch (51-mm) OD, black, molded-plastic grommets and matching plastic caps with slot for wire passage.
- M. Coat Hooks: Ives 580 A15, satin nickel finish, or equal.
- N. For concealed hardware, provide manufacturer's standard finish that complies with product class requirements in BHMA A156.9.
 - 1. US26D Dull Chrome.
- O. Hanger Rod: 1-1/16 inch diameter by length required chrome hanger rod with full flange chrome supports for screw attachment by U.S. Futaba, Inc. or equal.
- P. Rod Support & Shelf Bracket: Equal to U.S. Futaba, Inc. or equal. Item No. 72535 82 184 White. Shelf to be 14” deep.
- Q. Metal L-Shaped Counter Brackets: Constructed of A-36 steel plate 12-gauge, powder coated, with cable and conduit access, 21” x 24” verify width of counter. Basis of Design: Speedbrace www.fastcap.com.

2.6 MISCELLANEOUS MATERIALS

- A. Furring, Blocking, Shims, and Hanging Strips: Fire-retardant-treated softwood lumber, kiln dried to less than fifteen (15) percent moisture content.
- B. Anchors: Select material, type, size, and finish required for each substrate for secure anchorage. Provide metal expansion sleeves or expansion bolts for post-installed anchors. Use nonferrous-metal or hot-dip galvanized anchors and inserts at inside face of exterior walls and at floors.
- C. Adhesives: Do not use adhesives that contain urea formaldehyde.

2.6 FABRICATION

- A. Fabricate cabinets to dimensions, profiles, and details indicated.
- B. Complete fabrication, including assembly and hardware application, to maximum extent possible before shipment to Project site. Disassemble components only as necessary for shipment and installation. Where necessary for fitting at site, provide ample allowance for scribing, trimming, and fitting.
 - 1. Notify Architect seven days in advance of the dates and times woodwork fabrication will be complete.
 - 2. Trial fit assemblies at fabrication shop that cannot be shipped completely assembled. Install dowels, screws, bolted connectors, and other fastening devices that can be removed after trial fitting. Verify that various parts fit as intended and check measurements of assemblies against field measurements before disassembling for shipment.
- C. Shop-cut openings to maximum extent possible to receive hardware, appliances, electrical work, and similar items. Locate openings accurately and use templates or roughing-in diagrams to produce accurately sized and shaped openings. Sand edges of cutouts to remove splinters and burrs.

PART 3 - EXECUTION

3.1 PREPARATION

- A. Before installation, condition cabinets to average prevailing humidity conditions in installation areas.
- B. Before installing cabinets, examine shop-fabricated work for completion and complete work as required.

3.2 INSTALLATION

- A. Grade: Install cabinets to comply with same grade as item to be installed.
- B. Assemble cabinets and complete fabrication at Project site to the extent that it was not completed in the shop.
- C. Install cabinets level, plumb, true, and straight. Shim as required with concealed shims. Install level and plumb to a tolerance of 1/16-inch in 96 inches (1.5 mm in 2400 mm).

- D. Anchor cabinets to anchors or blocking built in or directly attached to substrates. Secure floor mounted cabinets and shelving to walls with countersunk, capped screws and/or blind nailing at 32 inches o.c. into wood framing or blocking as required for complete installation. Secure wall hung closed cabinets through back, near top and bottom, at ends and not more than 16 inches (400 mm) o.c. with No. 10 wafer-head screws sized for 1-inch (25-mm) penetration into wood framing, blocking, or hanging strips or No. 10 wafer-head sheet metal screws through metal backing or metal framing behind wall finish. Secure wall hung open cabinets and shelving with countersunk, capped screws at top and bottom at no less than 12 inches o.c.
 - 1. Use filler matching finish of items being installed.
- E. Cabinets: Install without distortion so doors and drawers fit openings properly and are accurately aligned. Adjust hardware to center doors and drawers in openings and to provide unencumbered operation. Complete installation of hardware and accessory items as indicated.
 - 1. Install cabinets with no more than 1/16-inch in 96-inch (3 mm in 2400-mm) sag, bow, or other variation from a straight line.
 - 2. Fasten wall cabinets through back, near top and bottom, and at ends not more than sixteen (16) inches (400 mm) o.c. with No. 10 wafer-head screws sized for not less than 1-1/2-inch (38-mm) penetration into wood framing, blocking, or hanging strips.
- F. Countertops: Anchor securely by screwing through corner blocks of base cabinets or other supports into underside of countertop.
 - 1. Align adjacent solid-surfacing-material countertops and form seams to comply with manufacturer's written recommendations using adhesive in color to match countertop. Carefully dress joints smooth, remove surface scratches, and clean entire surface.
 - 2. Install countertops with no more than 1/8 inch in 96-inch (3 mm in 2400-mm) sag, bow, or other variation from a straight line.
 - 3. Secure backsplashes to tops with concealed metal brackets at 16 inches (400 mm) o.c. and to walls with adhesive.
 - 4. Caulk space between backsplash and wall with sealant specified in Division 07 Section "Joint Sealants."

3.3 ADJUSTING AND CLEANING

- A. Repair damaged and defective cabinets, where possible, to eliminate functional and visual defects; where not possible to repair, replace woodwork. Adjust joinery for uniform appearance.
- B. Clean, lubricate, and adjust hardware.
- C. Clean cabinets on exposed and semi-exposed surfaces.

END OF SECTION 064116

THIS PAGE INTENTIONALLY BLANK

SECTION 066400 - PLASTIC PANELING

PART 1 - GENERAL

1.1 RELATED DOCUMENTS

- A. Drawings and general provisions of the Contract, including General and Supplementary Conditions and Division 01 Specification Sections, apply to this Section.

1.2 SUMMARY

- A. Section includes glass-fiber reinforced plastic (FRP) wall paneling and trim accessories, both standard embossed and smooth decorative panels.

1.3 SUBMITTALS

- A. Product Data: For each type of product indicated.
- B. Samples for Selection: For plastic paneling and trim accessories.

1.4 QUALITY ASSURANCE

- A. Source Limitations: Obtain plastic paneling and trim accessories from single manufacturer.
- B. Surface-Burning Characteristics: As determined by testing identical products according to ASTM E 84 by a qualified testing agency. Identify products with appropriate markings of applicable testing agency.
 - 1. Flame-Spread Index: 200 or less – Class C.
 - 2. Smoke-Developed Index: 450 or less.
 - 3. Testing Agency: Acceptable to authorities having jurisdiction UL.

1.5 PROJECT CONDITIONS

- A. Environmental Limitations: Do not deliver or install plastic paneling until spaces are enclosed and weathertight and temporary HVAC system is operating and maintaining ambient temperature and humidity conditions at occupancy levels during the remainder of the construction period.

PART 2 - PRODUCTS

2.1 PLASTIC SHEET PANELING

- A. General: Gelcoat-finished, glass-fiber reinforced plastic panels complying with ASTM D 5319.

1. Manufacturers: Subject to compliance with requirements, provide products by one of the following:
 - a. Kemlite Company Inc. / Crane Composites
 - b. Marlite.
 - c. Nudo Products, Inc.
2. Products and Surface Finish:
 - a. Molded pebble texture (embossed). “Crane Composites – Glasboard”.
 - b. Smooth decorative finish / color equal to “Crane Composites – Designs”.
3. Thicknesses and Product Locations:
 - a. Not less than 0.09 inch (2.3 mm) at embossed panels. Embossed panels to be utilized at **Kitchen** and **Janitorial** areas specified to have FRP panels.
 - b. Not less than .075 inch at smooth decorative panels. Smooth decorative panels to be utilized at Cafeteria serving alcoves specified to have decorative FRP panels.
4. Color: As selected by Architect from manufacturer's full range in each type.
5. Size: Up to 4’x10’ sheets, installed without horizontal joints, to heights shown on the drawings.

2.2 ACCESSORIES

- A. Trim Accessories: Manufacturer's standard one-piece vinyl extrusions designed to retain and cover edges of panels. Provide division bars, inside corners, outside corners, and caps as needed to conceal edges.
 1. Color: Match panels.
- B. Adhesive: As recommended by plastic paneling manufacturer.
 1. VOC Content: 50 g/L or less when calculated according to 40 CFR 59, Subpart D (EPA Method 24).
- C. Sealant: Single-component, mildew-resistant, acid-curing silicone sealant recommended by plastic paneling manufacturer and complying with requirements in Division 07 Section "Joint Sealants."
 1. VOC Content: 250 g/L or less when calculated according to 40 CFR 59, Subpart D (EPA Method 24).

PART 3 - EXECUTION

3.1 EXAMINATION

- A. Examine substrates and conditions, with Installer present, for compliance with requirements for installation tolerances and other conditions affecting performance of the Work.
- B. Proceed with installation only after unsatisfactory conditions have been corrected.

3.2 PREPARATION

- A. Remove materials that might interfere with adhesive bond.
- B. Prepare substrate by sanding high spots and filling low spots as needed to provide flat, even surface for panel installation.
- C. Clean substrates of substances that could impair bond of adhesive, including oil, grease, dirt, and dust.
- D. Condition panels by unpacking and placing in installation space before installation according to manufacturer's written recommendations.
- E. Lay out paneling before installing. Locate panel joints so that trimmed panels at corners are not less than 12 inches (300 mm) wide.
 - 1. Mark plumb lines on substrate at trim accessory locations for accurate installation.
 - 2. Locate trim accessories to allow clearance at panel edges according to manufacturer's written instructions.
- G. At masonry and concrete wall locations, FRP panels shall be installed over a layer of 5/8" water resistant gypsum board installed with construction adhesive to provide a smooth substrate for installation of the FRP panels.

3.3 INSTALLATION

- A. Install plastic paneling according to manufacturer's written instructions.
- B. Install panels in a full spread of adhesive.
 - 1. Apply adhesive immediately in advance of each individual panel installation. Do not allow adhesive to skin over.
 - 2. Shore panels in place until adhesive is fully set.
- C. Install trim accessories with adhesive. Do not fasten through panels. Terminate bottom of all vertical trim pieces 4" above floor as required to permit flush installation of resilient base.

- D. Fill grooves in trim accessories with sealant before installing panels and bed inside corner trim in a bead of sealant.
- E. Maintain uniform space between panels and wall fixtures. Fill space with sealant.
- F. Maintain uniform space between adjacent panels and between panels and floors, ceilings, and fixtures. Fill space with sealant.
- G. Remove excess sealant and smears as paneling is installed. Clean with solvent recommended by sealant manufacturer and then wipe with clean dry cloths until no residue remains.

END OF SECTION 066400

SECTION 071113 - BITUMINOUS DAMPPROOFING

PART 1 - GENERAL

1.1 RELATED DOCUMENTS

- A. Drawings and general provisions of the Contract, including Division 01 Specification Sections, apply to this Section.

1.2 SUMMARY

- A. This Section includes the following:
 - 1. Cold-applied, cut-back asphalt dampproofing.

1.3 SUBMITTALS

- A. Product Data: For each type of product indicated. Include recommendations for method of application, primer, number of coats, coverage or thickness, and protection course.
- B. Material Certificates: For each product, signed by manufacturers.
- C. LEED Submittal:
 - 1. Product Data for Credit EQ 4.2: For dampproofing, including printed statement of VOC content.

1.4 QUALITY ASSURANCE

- A. Source Limitations: Obtain primary dampproofing materials and primers through one source from a single manufacturer. Provide secondary materials recommended by manufacturer of primary materials.

1.5 PROJECT CONDITIONS

- A. Weather Limitations: Proceed with installation only when existing and forecasted weather conditions permit dampproofing to be performed according to manufacturers' written instructions.
- B. Ventilation: Provide adequate ventilation during application of dampproofing in enclosed spaces. Maintain ventilation until dampproofing has cured.

PART 2 - PRODUCTS

2.1 COLD-APPLIED, CUT-BACK ASPHALT DAMPPROOFING

- A. Manufacturers: Subject to compliance with requirements, provide products by one of the following:
 - 1. Henry Company.
 - 2. Karnak Corporation.
 - 3. Meadows, W. R., Inc.
- B. Dampproofing Brush and Spray Coats: ASTM D 4479, Type I, fibered.

2.2 MISCELLANEOUS MATERIALS

- A. Cut-Back Asphalt Primer: ASTM D 41.
- B. Patching Compound: As recommended by Dampproofing Manufacturer.

PART 3 - EXECUTION

3.1 EXAMINATION

- A. Examine substrates, with Installer present, for compliance with requirements for surface smoothness and other conditions affecting performance of work.
 - 1. Proceed with dampproofing application only after substrate construction and penetrating work have been completed and unsatisfactory conditions have been corrected.
 - 2. Test for surface moisture according to ASTM D 4263.

3.2 PREPARATION

- A. Protection of Other Work: Mask or otherwise protect adjoining exposed surfaces from being stained, spotted, or coated with dampproofing. Prevent dampproofing materials from entering and clogging weep holes and drains.
- B. Clean substrates of projections and substances detrimental to work; fill voids, seal joints, and apply bond breakers if any, as recommended by prime material manufacturer.
- C. Apply patching compound for filling and patching tie holes, honeycombs, reveals, and other imperfections.

3.3 APPLICATION, GENERAL

- A. Comply with manufacturer's written recommendations unless more stringent requirements are indicated or required by Project conditions to ensure satisfactory performance of dampproofing.
 - 1. Apply cut-back asphalt primer.
 - 2. Apply (2) coats dampproofing at coverage rate or thickness recommended by Manufacturer.
 - 3. Apply additional coats if recommended by manufacturer or if required to achieve coverages indicated.
 - 4. Allow each coat of dampproofing to cure 24 hours before applying subsequent coats.
 - 5. Allow 24 hours drying time prior to backfilling.

- B. Apply dampproofing to back side of all concrete retaining wall surfaces indicated, **below the elevation of indicated finish grade.**

3.4 CLEANING

- A. Remove dampproofing materials from surfaces not intended to receive dampproofing.

END OF SECTION 071113

THIS PAGE INTENTIONALLY BLANK

SECTION 071900 - WATER REPELLENTS

PART 1 - GENERAL

1.1 RELATED DOCUMENTS

- A. Drawings and general provisions of the Contract, including General and Supplementary Conditions and Division 01 Specification Sections, apply to this Section.

1.2 SUMMARY

- A. This Section includes penetrating water-repellent and anti-graffiti coating for the following vertical surfaces:
 - 1. Concrete masonry unit walls. (structural and veneer concrete masonry units)
 - 2. Exposed exterior concrete surfaces including retaining walls.

1.3 PERFORMANCE REQUIREMENTS

- A. Performance Testing: Provide water repellents that comply with test-performance requirements indicated, as evidenced by reports of tests performed by manufacturer by a qualified independent testing agency on manufacturer's standard products applied to substrates simulating those on Project using same application methods to be used for Project.
- B. Absorption: Minimum 90 percent reduction of absorption after 24 hours in comparison of treated and untreated specimens.
 - 1. Brick: ASTM C 67.
- C. Water Penetration and Leakage through Masonry: Minimum 90 percent reduction in leakage rate in comparison of treated and untreated specimens, per ASTM E 514.

1.4 SUBMITTALS

- A. Product Data: For each type of product indicated.
 - 1. Include manufacturer's printed statement of VOC content.
- B. Manufacturer Certificates: Signed by manufacturers certifying that water repellents comply with requirements.
- C. Qualification Data: For Installer.
- D. Product Test Reports: Based on evaluation of comprehensive tests performed by a qualified testing agency, for assemblies.

- E. Warranty: Special warranty specified in this Section.

1.5 QUALITY ASSURANCE

- A. Installer Qualifications: An employer of workers trained and approved by manufacturer.
- B. Test Application: Apply a finish sample for each type of water repellent and substrate required. Duplicate finish of approved sample.
 - 1. Locate each test application as directed by Architect.
 - 2. Size: 25 sq. ft. (2.3 sq. m).
 - 3. Final approval by Architect of water-repellent application will be from test applications.

1.6 PROJECT CONDITIONS

- A. Limitations: Proceed with application only when the following existing and forecasted weather and substrate conditions permit water repellents to be applied according to manufacturers' written instructions and warranty requirements:
 - 1. Ambient temperature is above 40 deg F (4.4 deg C).
 - 2. Concrete surfaces and mortar have cured for more than 28 days.
 - 3. Concrete or brick masonry walls are not treated prior to 30 days after building close-in.
 - 4. Rain or snow is not predicted within 24 hours.
 - 5. Application proceeds more than seven days after surfaces have been wet.
 - 6. Substrate is not frozen, or surface temperature is above 40 deg F (4.4 deg C).
 - 7. Windy conditions do not exist that may cause water repellent to be blown onto vegetation or surfaces not intended to be treated.

1.7 WARRANTY

- A. Special Warranty: Manufacturer's standard form in which manufacturer and Applicator agree(s) to repair or replace materials that fail to maintain water repellency specified in Part 1 "Performance Requirements" Article within specified warranty period.
 - 1. Warranty Period: Five years from date of Substantial Completion.

PART 2 - PRODUCTS

2.1 MANUFACTURERS

- A. Products: Subject to compliance with requirements, provide one of the products listed in other Part 2 articles.
 - 1. Products by other manufacturers are subject to Architect's approval prior to bidding.
- B. Proprietary-Blend, Solvent-Based Water Repellent: Clear, consisting of silicone elastomer and other compounds and components with 600 g/L or less of VOCs.

1. Penetrating Water Repellent / Anti-graffiti Coating (For use on all new exposed exterior masonry and concrete surfaces.)
 - a. Prosoco; Sure Klean Weather Seal Blok – Guard and Graffiti Control 15.
 - b. Other products are subject to Architect approval prior to bid.

PART 3 - EXECUTION

3.1 PREPARATION

- A. Clean substrate of substances that might interfere with penetration or performance of water repellents. Test for moisture content, according to water-repellent manufacturer's written instructions, to ensure that surface is dry enough.
- B. Test for pH level, according to water-repellent manufacturer's written instructions, to ensure chemical bond to silicate minerals.
- C. Protect adjoining work, including sealant bond surfaces, from spillage or blow-over of water repellent. Cover adjoining and nearby surfaces of aluminum and glass if there is the possibility of water repellent being deposited on surfaces. Cover live plants and grass.
- D. Coordination with Sealants: Do not apply water repellent until sealants for joints adjacent to surfaces receiving water-repellent treatment have been installed and cured.
 1. Water-repellent work may precede sealant application only if sealant adhesion and compatibility have been tested and verified using substrate, water repellent, and sealant materials identical to those used in the work.
- E. Proceed with installation only after unsatisfactory conditions have been corrected.

3.2 APPLICATION

- A. Manufacturer's Field Service: Engage a factory-authorized service representative to inspect the substrate before application of water repellent and to instruct Applicator on the product and application method to be used.
- B. Apply a mist coat of water repellent to break surface tension and to assist in penetration prior to application of saturation coat.
- C. Apply a heavy-saturation spray coating of water repellent on surfaces indicated for treatment using low-pressure spray equipment. Comply with manufacturer's written instructions for using airless spraying procedure, unless otherwise indicated. Apply from bottom up, with a controlled 8 inches to 10 inches of rundown. Application rate shall be no less than one gallon per 60 square feet, and greater if required based on review of test application.
- D. Comply with manufacturer's written instructions. Consult manufacturer's technical representative if written instructions are not applicable to Project conditions.

3.3 CLEANING

- A. Immediately clean water repellent from adjoining surfaces and surfaces soiled or damaged by water-repellent application as work progresses. Repair damage caused by water-repellent application. Comply with manufacturer's written cleaning instructions.

END OF SECTION 071900

SECTION 072100 - THERMAL INSULATION

PART 1 - GENERAL

1.1 RELATED DOCUMENTS

- A. Drawings and general provisions of the Contract, including General and Supplementary Conditions and Division 01 Specification Sections, apply to this Section.

1.2 SUMMARY

- A. This Section includes the following:
 - 1. Perimeter wall insulation (interior and supporting backfill).
 - 2. Concealed building insulation, blanket / batt and blown.
 - 3. Expandable foam insulation.
 - 4. Vapor retarders.

1.3 SUBMITTALS

- A. Product Data: For each type of product indicated.

1.4 QUALITY ASSURANCE

- A. Source Limitations: Obtain each type of building insulation through one source from a single manufacturer.
- B. Fire-Test-Response Characteristics: Provide insulation and related materials with the fire-test-response characteristics indicated, as determined by testing identical products per test method indicated below by UL or another testing and inspecting agency acceptable to authorities having jurisdiction. Identify materials with appropriate markings of applicable testing and inspecting agency.
 - 1. Surface-Burning Characteristics: ASTM E 84.
 - 2. Fire-Resistance Ratings: ASTM E 119.
 - 3. Combustion Characteristics: ASTM E 136..

1.5 DELIVERY, STORAGE, AND HANDLING

- A. Protect insulation materials from physical damage and from deterioration by moisture, soiling, and other sources. Store inside and in a dry location. Comply with manufacturer's written instructions for handling, storing, and protecting during installation.
- B. Protect plastic insulation as follows:

1. Do not expose to sunlight, except to extent necessary for period of installation and concealment.
2. Protect against ignition at all times. Do not deliver plastic insulating materials to Project site before installation time.
3. Complete installation and concealment of plastic materials as rapidly as possible in each area of construction.

PART 2 - PRODUCTS

2.1 MANUFACTURERS

- A. In other Part 2 articles where titles below introduce lists, the following requirements apply to product selection:
 1. Products: Subject to compliance with requirements, provide one of the products specified.
 2. Manufacturers: Subject to compliance with requirements, provide products by one of the manufacturers specified.
- B. Products by other manufacturers are subject to approval by the Architect prior to bidding.

2.2 FOAM-PLASTIC BOARD INSULATION

- A. Extruded-Polystyrene Board Insulation: ASTM C 578, of type and density indicated below, with maximum flame-spread and smoke-developed indexes of 75 and 450, respectively:
 1. Manufacturers:
 - a. DiversiFoam Products.
 - b. Dow Chemical Company.
 - c. Owens Corning.
 - d. Pactiv Building Products Division.
 2. Type IV, 1.60 lb/cu. ft. (26 kg/cu. m), supporting backfill unless otherwise indicated.
 3. Use Expanded-Polystyrene Board (EPS) Insulation at incidental interior wall applications
 4. Thicknesses: As indicated on Drawings. Alternative manufacturer of ½ inch slab isolation board is acceptable.

2.3 GLASS-FIBER BLANKET / BATT INSULATION AND BLOWN INSULATION

- A. Manufacturers:
 1. CertainTeed Corporation.
 2. Guardian Fiberglass, Inc.
 3. Johns Manville.
 4. Knauf Fiber Glass.

5. Owens Corning.

B. Unfaced, Glass-Fiber Blanket Insulation: ASTM C 665, Type I (blankets without membrane facing); consisting of fibers; with maximum flame-spread and smoke-developed indexes of 25 and 50, respectively; passing ASTM E 136 for combustion characteristics.

C. Where glass-fiber blanket insulation is indicated by the following thicknesses, provide blankets in batt or roll form with thermal resistances indicated:

1. 3-1/2 inches (89 mm) thick with a thermal resistance of 15 deg F x h x sq. ft./Btu at 75 deg F (1.9 K x sq. m/W at 24 deg C).
2. 5 1/2 inches (140mm) thick with a thermal resistance of 21 deg F x h x sq. f.t./BTU at 75 deg F (3.3K x sq. m/w at 24 deg C).

D. Glass-Fiber Blown Insulation: ASTM C764.

2.4 EXPANDABLE FOAM INSULATION

A. Manufacturers / Products of Expandable Foam Insulation:

1. Products subject to Architect approval for specific applications required.

2.5 VAPOR RETARDERS

A. Fire-Retardant, Reinforced-Polyethylene Vapor Retarders: 2 outer layers of polyethylene film laminated to an inner reinforcing layer consisting of either nonwoven grid of nylon cord or polyester scrim and weighing not less than 22 lb/1000 sq. ft. (10 kg/100 sq. m), with maximum permeance rating of 0.1317 perm (7.56 ng/Pa x s x sq. m) and with flame-spread and smoke-developed indexes of not more than 5 and 60, respectively.

1. Products:

- a. Raven Industries Inc.; DURA-SKRIM 2FR.
- b. Reef Industries, Inc.; Griffolyn T-55 FR.

B. Vapor-Retarder Tape: Pressure-sensitive tape of type recommended by vapor-retarder manufacturer for sealing joints and penetrations in vapor retarder.

C. Vapor-Retarder Fasteners: Pancake-head, self-tapping steel drill screws; with fender washers.

D. Single-Component Nonsag Urethane Sealant: ASTM C 920, Type I, Grade NS, Class 25, Use NT related to exposure, and Use O related to vapor-barrier-related substrates.

2.6 AUXILIARY INSULATING MATERIALS

A. Vapor-Retarder Tape: Pressure-sensitive tape of type recommended by insulation manufacturers for sealing joints and penetrations in vapor-retarder facings.

PART 3 - EXECUTION

3.1 EXAMINATION

- A. Examine substrates and conditions, with Installer present, for compliance with requirements of Sections in which substrates and related work are specified and for other conditions affecting performance.
 - 1. Proceed with installation only after unsatisfactory conditions have been corrected.

3.2 PREPARATION

- A. Clean substrates of substances harmful to insulation or vapor retarders, including removing projections capable of puncturing vapor retarders or of interfering with insulation attachment.

3.3 INSTALLATION, GENERAL

- A. Comply with insulation manufacturer's written instructions applicable to products and application indicated.
- B. Install insulation that is undamaged, dry, and unsoiled and that has not been left exposed at any time to ice, rain, and snow.
- C. Extend insulation in thickness indicated to envelop entire area to be insulated. Cut and fit tightly around obstructions and fill voids with insulation. Remove projections that interfere with placement.
- D. Water-Piping Coordination: If water piping is located within insulated exterior walls, coordinate location of piping to ensure that it is placed on warm side of insulation and insulation encapsulates piping.
- E. For preformed insulating units, provide sizes to fit applications indicated and selected from manufacturer's standard thicknesses, widths, and lengths. Apply single layer of insulation units to produce thickness indicated unless multiple layers are otherwise shown or required to make up total thickness.

3.4 INSTALLATION OF PERIMETER INSULATION

- A. On vertical surfaces, set insulation units in adhesive applied according to manufacturer's written instructions. Use adhesive recommended by insulation manufacturer.
 - 1. If not otherwise indicated, extend insulation a minimum of 24 inches (610 mm) below exterior grade line.
- B. Install ½ inch separation board between edge of floor slab and inside face of foundation wall as indicated on the Drawings.

- C. Protect below-grade insulation on vertical surfaces from damage during backfilling by applying protection course with joints butted. Set in adhesive according to insulation manufacturer's written instructions.
- D. Protect top edge of insulation from damage during concrete work.

3.5 INSTALLATION OF GENERAL BUILDING INSULATION

- A. Apply insulation units to substrates by method indicated, complying with manufacturer's written instructions. If no specific method is indicated, bond units to substrate with adhesive or use mechanical anchorage to provide permanent placement and support of units.
- B. Install mineral-fiber insulation in cavities formed by framing members according to the following requirements:
 - 1. Use insulation widths and lengths that fill the cavities formed by framing members. If more than one length is required to fill cavity, provide lengths that will produce a snug fit between ends.
 - 2. Place insulation in cavities formed by framing members to produce a friction fit between edges of insulation and adjoining framing members.
 - 3. Maintain 3-inch (76-mm) clearance of insulation around recessed lighting fixtures.
 - 4. For wood-framed wall cavities where cavity heights exceed 96 inches (2438 mm), support unfaced blankets mechanically.
 - 5. Install blown insulation in soffit and other cavities where indicated on Drawings. Fill cavities in their entirety.
- C. Install expandable foam insulation in cavities around exterior door units per manufacturer's instructions.

3.6 INSTALLATION OF VAPOR RETARDERS

- A. General: Extend vapor retarder to extremities of areas to be protected from vapor transmission. Secure in place prior to installation of gypsum board. Extend vapor retarder to cover miscellaneous voids in insulated substrates.
- B. Seal vertical joints in vapor retarders over framing by lapping not less than two wall studs.
- C. Before installing vapor retarder, apply urethane sealant to wood framing including still plates, wood studs, and framing around door and window openings. Seal overlapping joints in vapor retarders with vapor-retarder tape according to vapor-retarder manufacturer's written instructions. Seal butt joints with vapor-retarder tape. Locate all joints over framing members or other solid substrates.
- D. Firmly attach vapor retarders to wood framing and solid substrates with vapor-retarder fasteners as recommended by vapor-retarder manufacturer.

- E. Seal joints caused by pipes, conduits, electrical boxes, and similar items penetrating vapor retarders with vapor-retarder tape to create an airtight seal between penetrating objects and vapor retarder.
- F. Repair tears or punctures in vapor retarders immediately before concealment by other work. Cover with vapor-retarder tape or another layer of vapor retarder.

3.7 PROTECTION

- A. Protect installed insulation and vapor retarders from damage due to harmful weather exposures, physical abuse, and other causes. Provide temporary coverings or enclosures where insulation is subject to abuse and cannot be concealed and protected by permanent construction immediately after installation.

END OF SECTION 072100

SECTION 072700 – INFILTRATION BARRIERS

PART 1 - GENERAL

1.1 RELATED DOCUMENTS

- A. Drawings and general provisions of the Contract, including General and Supplementary Conditions and Division 1 Specification Sections, apply to this Section.

1.2 SUMMARY

- A. This Section includes the following:
 - 1. Infiltration barrier at exterior wall sheathing and miscellaneous locations.

1.3 SUBMITTALS

- A. Product Data: For each type of process and factory-fabricated product.

1.4 QUALITY ASSURANCE

- A. Fire-Test-Response Characteristics: For assemblies with fire-resistance ratings, provide materials and construction identical to those of assemblies tested for fire resistance per ASTM E 119 by a testing and inspecting agency acceptable to authorities having jurisdiction.

PART 2 - PRODUCTS

2.1 INFILTRATION BARRIER MATERIALS

- A. Infiltration Barrier: Engineered textured – surface membranes for application over sheathing at exterior wall and miscellaneous locations.
 - 1. Dupont Tyvek “Commercial Wrap”, (1) layer.
- B. Products by other manufacturers are subject to approval prior to bidding.

2.2 MISCELLANEOUS MATERIALS

- A. Flexible Flashing: Composite, self-adhesive, flashing product for use at window and door openings.
 - 1. Products: Subject to compliance with requirements, provide of the following:

- a. Grace Construction Products, a unit of W. R. Grace & Co. "Bituthene".

PART 3 - EXECUTION

3.1 INSTALLATION, GENERAL

- A. Coordinate air barrier installation with installation of composite wall panels and metal soffit panels, trim, etc.

3.2 INFILTRATION BARRIER INSTALLATION

- A. General: Cover exterior sheathing with infiltration barrier applied in accordance with manufacturer's printed instructions. Install with fasteners of type and at spacings recommended by manufacturer. Lap and seal seams per manufacturer's recommendations.

3.3 FLEXIBLE FLASHING INSTALLATION

- A. Apply flexible flashing at all penetrations to comply with manufacturers written instructions and with details on the Drawings. Install over top of infiltration barrier material and adhere to surface of penetrating item.

END OF SECTION 072700

SECTION 075423 - THERMOPLASTIC POLYOLEFIN (TPO) ROOFING

PART 1 - GENERAL

1.1 RELATED DOCUMENTS

- A. Drawings and general provisions of the Contract, including General and Supplementary Conditions and Division 01 Specification Sections, apply to this Section.

1.2 SUMMARY

- A. Section Includes:

- 1. Mechanically fastened TPO membrane roofing system, including flashings.
 - a. Roof insulation.
 - b. Vapor retarder.
 - c. Substrate board.
 - d. Auxiliary materials for complete roofing system.
 - e. Existing roofing repairs, and installation of new flashings at areas of existing roofing receiving new roof penetrations, equipment curbs, and other construction, are included in this Section.

1.3 DEFINITIONS

- A. TPO: Thermoplastic Polyolefin.
- B. EPDM: Ethylene Propylene Diene Monomer.
- C. Roofing Terminology: See ASTM D 1079 and glossary in NRCA's "The NRCA Roofing and Waterproofing Manual" for definitions of terms related to roofing work in this Section.

1.4 PERFORMANCE REQUIREMENTS

- A. General Performance: Installed membrane roofing and base flashings shall withstand specified uplift pressures, thermally induced movement, and exposure to weather without failure due to defective manufacture, fabrication, installation, or other defects in construction. Membrane roofing and base flashings shall remain watertight.
- B. Material Compatibility: Provide roofing materials that are compatible with one another under conditions of service and application required, as demonstrated by membrane roofing manufacturer based on testing and field experience.

- C. UL Approvals Listing: Provide new TPO membrane roofing system and associated materials to provide an Underwriters Laboratories Class A or B roofing assembly applied to combustible construction. Identify materials with UL Approvals markings.
- D. Roofing System Design: Provide membrane roofing system that is identical to systems that have been successfully tested by a qualified testing and inspecting agency to resist uplift pressure calculated by manufacturer according to ASCE/SEI 7.

1.5 SUBMITTALS

- A. Product Data: For each type of product indicated.
- B. Shop Drawings: For new roofing system. Include plans, elevations, sections, details, and attachments to other work.
 - 1. Base flashings and membrane terminations.
 - 2. Tapered insulation, including slopes.
 - 3. Roof plan showing orientation of steel roof deck and orientation of membrane roofing and fastening spacings and patterns for mechanically fastened membrane roofing.
 - 4. Insulation and substrate fastening patterns for corner, perimeter, and field-of-roof locations.
 - 5. Wind uplift calculations to satisfy the requirements of 1.4.C. above, the International Building Code, 2018 Edition (IBC), and the following:
 - a. IBC Chapter 16 requirements, including Wind Speed.
 - b. Building Risk Category III.
 - c. Surface Roughness Category C.
- C. Qualification Data: For qualified Installer.
 - 1. Submit evidence of compliance with performance requirements.

1.6 QUALITY ASSURANCE

- A. Installer Qualifications: A qualified firm that is approved, authorized, or licensed by TPO membrane roofing system manufacturer to install manufacturer's product and that is eligible to receive manufacturer's special warranty.
- B. Source Limitations: Obtain components including roof insulation, fasteners, sealants, etc. for TPO membrane roofing system from same manufacturer as membrane roofing or from a source approved by membrane roofing manufacturer.
- C. Exterior Fire-Test Exposure for New Roofing System: UL Class A or Class B for application and roof slopes indicated, as determined by testing identical membrane roofing materials. Materials shall be identified with appropriate markings of Underwriters Laboratories.
- D. Preinstallation Roofing Conference: Conduct conference at Project site.

1. Meet with Architect, and roofing installer.
 2. Review methods and procedures related to roofing installation, including manufacturer's written instructions.
 3. Review structural loading limitations of roof deck during and after roofing.
 4. Review flashings, special roofing details, roof drainage, roof penetrations, equipment curbs, and condition of other construction that will affect roofing system.
 5. Review temporary protection requirements for roofing system during and after installation.
- E. Roofing membrane manufacturer's representative shall probe full length of all field seams of roofing membrane, all "tee" seam patches, all flashing membrane seams, and all corner patch seams during his acceptance inspection(s). Handle extensions on probing device shall not be permitted. Reinspections(s) by roofing membrane manufacturer's representative, at Contractor's expense, shall be required if open seams are subsequently discovered. Probing of seams by Contractor shall not relieve manufacturer's representative from the requirements of this Paragraph. Copies of manufacturer's field reports are to be sent to the Architect and Construction Manager.

1.7 DELIVERY, STORAGE, AND HANDLING

- A. Deliver roofing materials to Project site in original containers with seals unbroken and labeled with manufacturer's name, product brand name and type, date of manufacture, approval or listing agency markings, and directions for storing and mixing with other components.
- B. Store liquid materials in their original undamaged containers in a clean, dry, protected location and within the temperature range required by roofing system manufacturer. Protect stored liquid material from direct sunlight.
 1. Discard and legally dispose of liquid material that cannot be applied within its stated shelf life.
- C. Protect roof insulation materials from physical damage and from deterioration by sunlight, moisture, soiling, and other sources. Store in a dry location. Comply with insulation manufacturer's written instructions for handling, storing, and protecting during installation.
- D. Handle and store roofing materials and place equipment in a manner to avoid permanent deflection of deck.

1.8 PROJECT CONDITIONS

- A. Weather Limitations: Proceed with installation only when existing and forecasted weather conditions permit roofing system to be installed according to manufacturer's written instructions and warranty requirements.

1.9 WARRANTY

- A. Manufacturer's Warranty for New Roofing System: Manufacturer's standard or customized form, without monetary limitation, in which manufacturer agrees to repair or replace

components of membrane roofing system that fail in materials or workmanship within specified warranty period.

1. Manufacturer's warranty includes membrane roofing, base flashings, roof insulation, fasteners, substrate board, roofing accessories, and other components of membrane roofing system.
 2. Warranty Period: 20 years from date of Substantial Completion.
- B. Special Project Warranty: Submit roofing Installer's warranty, on warranty form at end of this Section, signed by Installer, covering the Work of this Section, including all components of membrane roofing system such as membrane roofing, base flashing, roof insulation, fasteners, and substrate boards for the following warranty period:
1. Warranty Period: Three years from date of Substantial Completion.

PART 2 - PRODUCTS

2.1 TPO MEMBRANE ROOFING

- A. Fabric-Reinforced Thermoplastic Polyolefin Sheet: ASTM D 6878, internally fabric or scrim reinforced, uniform, flexible TPO sheet.
1. Manufacturers: Subject to compliance with requirements, provide products by one of the following:
 - a. Carlisle SynTec Incorporated.
 - b. Firestone Building Products Company.
 - c. GAF Materials Corporation.
 - d. Johns Manville
 2. Products by other manufacturers are subject to Architect's approval prior to bidding.
 3. Thickness: 60 mils, nominal.
 4. Color: White.

2.2 AUXILIARY MEMBRANE ROOFING MATERIALS

- A. General: Auxiliary membrane roofing materials recommended by roofing system manufacturer for intended use, and compatible with membrane roofing.
- B. Sheet Flashing: Manufacturer's standard unreinforced thermoplastic polyolefin sheet flashing, of same color as sheet membrane.
- C. Bonding Adhesive: Manufacturer's standard.
- D. Low Rise Foam Adhesive: Dual component low rise polyurethane adhesive approved by roofing manufacturer.
- E. Slip Sheet: Manufacturer's standard, of thickness required for application.

- F. Metal Termination Bars: Manufacturer's standard, predrilled stainless-steel or aluminum bars, approximately 1 by 1/8 inch (25 by 3 mm) thick; with anchors.
- G. Fasteners: Factory-coated steel fasteners and metal plates complying with corrosion-resistance provisions in FM Approvals 4470, designed for fastening membrane to substrate, and acceptable to membrane roofing system manufacturer.
- H. Walkway material: Material for forming walkways on the roof surface as shown on the Drawings shall be roofing membrane manufacturer's TPO walkway material in continuous rolls or individual pads, 30" width minimum, designed for heat welding to the roof surface.
- I. Self-Adhesive Membrane Strip: TPO flashing membrane material in rolled 6 inch (approximate) wide strips intended for stripping in flashings, membrane tie ins, etc.
- J. Miscellaneous Accessories: Provide sealers, preformed cone and vent sheet flashings, preformed inside and outside corner sheet flashings, T-joint covers, lap sealants, termination reglets, and other accessories.
- K. TPO Coated Metal: Where indicated on the Drawings, metal flashings, etc. shall be sheet steel, factory coated with a TPO material to which the roof membrane may be heat welded. Such coated metal shall be as manufactured by and as furnished by the manufacturer of the roofing membrane. Coated metal so furnished shall be fabricated to required shapes by local fabricator or by roof membrane manufacturer at Contractor's option. Gauges, sizes and details of coated metal installations shall be shown on the drawing. Coated color shall match color of TPO membrane.

2.3 SUBSTRATE BOARDS

- A. Substrate Board: ASTM C 1177/C 1177M, glass-mat, water-resistant gypsum substrate, thicknesses as indicated.
 - 1. Products: Subject to compliance with requirements, provide the following:
 - a. Georgia-Pacific Corporation; Dens Deck, ¼ inch.
 - b. Georgia-Pacific Dens Deck Prime at adhered membrane flashings, ½ inch.
 - 2. Products by other manufacturers are subject to Architect's approval prior to bidding.
- B. Fasteners: Factory-coated steel fasteners and metal plates complying with corrosion-resistance provisions in FM Approvals 4470, designed for fastening substrate board to roof deck.

2.4 ROOF INSULATION

- A. General: Preformed roof insulation boards manufactured or approved by TPO membrane roofing manufacturer, selected from manufacturer's standard sizes suitable for application, of thicknesses indicated and that produce required UL classification for roofing assembly.
- B. Polyisocyanurate Board Insulation: ASTM C 1289, Type II, Class 1, glass-fiber mat facer on both major surfaces. Install in multiple layers as indicated on Drawings. Polyisocyanurate board manufacturers / materials shall be approved in writing by roofing membrane manufacturer.

- C. Tapered Insulation: Provide factory-tapered insulation boards fabricated to slopes and thicknesses indicated on the Drawings to provide drainage patterns indicated on the Drawings.
1. Molded Polystyrene Insulation: Rigid, cellular, thermal insulation formed by the expansion of polystyrene resin beads or granules in a closed mold to comply with ASTM C 578 for Type indicated and as follows for tapered insulation applications.
 - a. Type II, 1.35-pcf minimum density, aged r-value of 4.4 and 4.0 at 40 deg and 75 deg F (4.4 deg and 23.9 deg C), respectively.
 - b. Surface-Burning Characteristics: Maximum flame-spread and smoke-developed values of 75 and 175, respectively.
 - c. Molded polystyrene board shall be Underwriters Laboratories classified (documentation required).
 - d. Provide tapered boards where indicated for sloping to drain. Fabricate crickets with taper and pattern as indicated on the Drawings. Cricket slope shall be no less than ½-inch slope from horizontal plane.
 - e. Contractor shall field verify all conditions related to tapered insulation system installation, including dimensions, slopes, drain and scupper locations etc.
 - f. Contractor shall provide fabrication / installation drawings of tapered insulation system for Architect’s review prior to fabrication.
 2. Polyisocyanurate Board Insulation: ASTM C 1289, Type II, Class 1, glass-fiber mat facer on both major surfaces. Install in multiple layers with tapered insulation sandwiched between as indicated on Drawings. Board thickness as indicated on Drawings with thickness no less than 1/4-inch (6.32mm) at special conditions. A net ¼-inch slope must be maintained with ½- inch slope at built-up crickets, unless otherwise indicated on Drawings. Significant ponding water because of incorrectly installed insulation will be resolved at the contractor’s cost. Polyisocyanurate board manufacturers / materials shall be approved in writing by roofing membrane manufacturer.
- D. Provide preformed saddles, crickets, tapered edge strips, and other insulation shapes where indicated for sloping to drain. Fabricate to slopes indicated.

2.5 INSULATION ACCESSORIES

- A. General: Furnish roof insulation accessories recommended by insulation manufacturer for intended use and compatibility with membrane roofing.
- B. Fasteners: Factory-coated steel fasteners and metal plates complying with corrosion-resistance provisions in FM Approvals 4470, designed for fastening roof insulation to substrate, and acceptable to roofing system manufacturer.

2.6 VAPOR RETARDER

- A. Vapor retarder shall be a reinforced polyethylene laminate as follows:
 1. Reef Industries “Griffolyn TX-1200 FR” with “Griftape FR” foil tape seaming tape, 4” wide.

2. Products by other manufacturers meeting composition and physical properties of the vapor retarder indicated above are subject to approval prior to bidding.

NOTE: Adhesive / seam sealer is not approved. If manufacturer of vapor retarder cannot furnish or approve a foil seaming tape, that manufacturer is not approved.

PART 3 - EXECUTION

3.1 EXAMINATION

- A. Examine substrates, areas, and conditions, with Installer present, for compliance with the following requirements and other conditions affecting performance of roofing system:
 1. Verify that roof openings and penetrations are in place and curbs are set and braced and that roof drain bodies are securely clamped in place.
 2. Verify that wood blocking, curbs, and nailers are securely anchored to roof deck at penetrations and terminations and that nailers match thicknesses of insulation.
- B. Proceed with installation only after unsatisfactory conditions have been corrected.
- C. Protect existing roofing assemblies from damage during the course of adjacent roofing work and during repairs and required modifications to existing roofing.

3.2 PREPARATION

- A. Clean substrate of dust, debris, moisture, and other substances detrimental to roofing installation according to roofing system manufacturer's written instructions. Remove sharp projections.
- B. Prevent materials from entering and clogging roof drains and conductors and from spilling or migrating onto surfaces of other construction. Remove roof-drain plugs when no work is taking place or when rain is forecast.
- C. Complete terminations and base flashings and provide temporary seals to prevent water from entering completed sections of roofing system at the end of the workday or when rain is forecast. Remove and discard temporary seals before beginning work on adjoining roofing.

3.3 SUBSTRATE BOARD

- A. Install substrate board with long joints in continuous straight lines, perpendicular to roof slopes with end joints staggered between rows. Tightly butt substrate boards together.
 1. Fasten substrate board to top of steel roof deck according to membrane roofing system manufacturers' written instructions, but with no less than 6 fasteners per 4' x 8' panel.
 2. Fasten membrane flashing substrate board to wall and parapet studs with screws of type and spacing recommended by manufacturer of substrate board.

3.4 VAPOR RETARDER INSTALLATION

- A. General: Install vapor retarder over entire roof surface over substrate board. Seal to all walls, parapet sheathing, penetrations, curbs, etc. with urethane sealant and as shown on the Drawings. Lap adjacent sheets 2" on sides and 6" at ends.
- B. Sealing of Laps: Seal all laps with seaming tape continuous and centered on lap edge. Roll down laps.
- C. Protection: Protect installed vapor retarder from any and all damage and immediately repair any damage using lapping and sealing techniques specified. Use special care when working over installed vapor retarder.

3.5 INSULATION INSTALLATION

- A. Coordinate installing membrane roofing system components so insulation is not exposed to precipitation or left exposed at the end of the workday.
- B. Comply with membrane roofing system and insulation manufacturer's written instructions for installing roof insulation.
- C. Install tapered insulation between the two layers of polyisocyanurate insulation to conform to slopes indicated.
- D. Install insulation under area of roofing to achieve required thickness.
- E. Trim surface of insulation where necessary at roof drains so completed surface is flush and does not restrict flow of water.
- F. Install insulation with long joints of insulation in a continuous straight line with end joints staggered between rows, abutting edges and ends between boards. Fill gaps exceeding 1/4 inch (6 mm) with insulation.
 - 1. Cut and fit insulation within 1/4 inch (6 mm) of nailers, projections, and penetrations.
 - 2. Miter cut insulation at valleys and ridges. Do not bend insulation through valleys or over ridges.
 - 3. At areas of existing roofing assembly infill, match existing roof and cricket insulation thickness and slope.
- G. Mechanically Fastened Insulation: Install each layer of insulation and secure to deck using mechanical fasteners of type and spacings specifically recommended by roof system manufacturer.
 - 1. Mechanical fasteners shall be of 3 inch square or round galvanized steel plate / corrosion resistant coated screw type.
 - 2. Fasten top layer of insulation to resist uplift pressure at corners, perimeter, and field of roof, but with no less than 8 fasteners per 4' x 8' panel and 5 fasteners per 4' x 4' panel.

3.6 MECHANICALLY FASTENED MEMBRANE ROOFING INSTALLATION

- A. Mechanically fasten membrane roofing over area to receive roofing and install according to roofing system manufacturer's written instructions.
 - 1. For in-splice attachment, install membranes roofing with long dimension perpendicular to steel roof deck flutes.
- B. Accurately align membrane roofing and maintain uniform side and end laps of minimum dimensions required by manufacturer. Stagger end laps.
- C. Mechanically fasten or adhere membrane roofing securely at terminations, penetrations, and perimeter of roofing.
- D. Apply membrane roofing with side laps shingled with slope of roof deck where possible.
- E. In-Seam Attachment: Secure one edge of TPO sheet using fastening plates or metal battens centered within membrane seam and mechanically fasten TPO sheet to roof deck.
- F. Seams: Clean seam areas, overlap membrane roofing, and hot-air weld side and end laps of membrane roofing and sheet flashings according to manufacturer's written instructions to ensure a watertight seam installation. Clean and prepare existing membrane and flashings for attachment and welding of new membrane and flashings per manufacturer's instructions.
 - 1. Test all lap edges with probe to verify seam weld continuity. Apply lap sealant to seal cut edges of sheet membrane.
 - 2. Verify field strength of seams a minimum of twice daily and repair seam sample areas.
 - 3. Repair tears, voids, and lapped seams in roofing that does not comply with requirements.
- G. Spread sealant bed over deck drain flange at roof drains and securely seal membrane roofing in place with clamping ring.

3.7 FLASHING INSTALLATION

- A. Install sheet flashings and preformed flashing accessories and fully adhere to specified substrate board and other substrates according to membrane roofing system manufacturer's written instructions.
- B. Apply bonding adhesive to substrate and underside of sheet flashing at required rate and allow to partially dry. Do not apply to seam area of flashing.
- C. Flash penetrations and field-formed inside and outside corners with cured or uncured sheet flashing.
- D. Clean seam areas, overlap, and firmly roll sheet flashings into the adhesive. Hot-air weld side and end laps to ensure a watertight seam installation.
- E. Terminate and seal top of sheet flashings and mechanically anchor to substrate through termination bars. Install intermediate and top termination bars per details on Drawings.
- F. Membrane shall be installed without wrinkles and/or misaligned sheets. Care shall be taken to avoid adhesive or sealant staining of exposed surfaces. Care shall be taken to avoid necessity

for patching of exposed surfaces. Excessive wrinkles, misaligned sheets, staining, and/or excessive patches shall be cause for rejection of the installed membrane.

- G. Install new flashing at existing roofing where required for new penetrations and curbs per details on Drawings and manufacture's requirements.

3.8 FIELD QUALITY CONTROL

- A. Final Roof Inspection: Arrange for roofing system manufacturer's technical personnel to inspect roofing installation on completion.
- B. Repair or remove and replace components of membrane roofing system where inspections indicate that they do not comply with specified requirements.
- C. Additional inspections, at Contractor's expense, will be performed to determine compliance of replaced or additional work with specified requirements.
- D. Roofing membrane manufacturer's representative shall probe full length of all field seams of roofing membrane, all "tee" seam patches, all corner patches, and all flashing membrane seams. Handle extensions on probing device shall not be permitted.

3.9 PROTECTING AND CLEANING

- A. Protect membrane roofing system from damage and wear during remainder of construction period. When remaining construction will not affect or endanger roofing, inspect roofing for deterioration and damage, describing its nature and extent in a written report, with copies to Architect and Owner.
- B. Correct deficiencies in or remove membrane roofing system that does not comply with requirements; repair substrates; and repair or reinstall membrane roofing system to a condition free of damage and deterioration at time of Substantial Completion and according to warranty requirements.
- C. Clean overspray and spillage from adjacent construction using cleaning agents and procedures recommended by manufacturer of affected construction.

END OF SECTION 075423

ROOFING WARRANTY

WHEREAS _____

Of (Address) _____

herein called the "Roofing Contractor", has performed roofing and associated ("work") on following project:

Owner: _____

Address: _____

Name and Type of Building: _____

Address: _____

Area of Work: _____ Date of Acceptance: _____

Warranty Period: Three (3) years Date of Expiration: _____

AND WHEREAS Roofing Contractor has contracted (either directly with Owner or indirectly as subcontractor) to warrant said work against leaks and faulty or defective materials and workmanship for designated Warranty Period.

NOW THEREFORE Roofing Contractor hereby warrants, subject to terms and conditions herein set forth, that during Warranty period he will at his own cost and expense, make or cause to be made such repairs to or replacements of said work as are necessary to correct faulty and defective work, and as are necessary to maintain said work in watertight condition.

In addition to making the work watertight, the Roofing Contractor shall remove and / or repair blisters, ridges, flashings, splits and other irregularities which in the opinion of the Roofing Manufacturer's technical representative do not conform to acceptable roofing practices and conditions. These repairs shall be made prior to expiration of the three (3) year Warranty period and to the satisfaction of the Roofing Manufacturer's technical representative.

1. This Warranty is made subject to the following terms and conditions:

Specifically excluded from this Warranty are damages to work and other parts of the building, and to building contents, caused by: a) lightning; windstorm; b) fire; c) Failure of roofing deflection, deterioration, and decomposition; d) faulty construction of parapet walls, copings, chimneys, skylights, vents, equipment supports, and other edge conditions and penetrations of the work; and e) activity on roofing by others including construction contractors, maintenance personnel, other persons, and animals whether authorized or unauthorized by Owner.

When Work has been damaged by any foregoing causes, Warranty shall be null and void until such damage has been repaired by Roofing Contractor, and until cost and expense thereof has been paid by Owner or by another responsible party so designated.

1. The Roofing Contractor is responsible for damage to work covered by this Warranty, but is not consequential to damages to building or building contents, resulting from leaks or faults or defects of work.
2. During Warranty Period, if Owner allows alteration of work by anyone other than Roofing Contractor, including cutting, patching and maintenance in connection with penetrations, attachment of other work, and positioning of anything on roof, this Warranty shall become null and void upon date of said alterations, but only to extent said alterations affect work covered by this Warranty. If Owner engages Roofing Contractor to perform said alterations, Warranty shall not become null and void, unless Roofing Contractor, prior to proceeding with said work, shall claim that said alterations would like damage or deteriorate work, thereby reasonably justifying a limitation of termination of this Warranty.
3. During Warranty period, if original use of roof is changed and it becomes used for, but was not originally specified for, a promenade, work deck, spray cooled surface, flooded basin, or other use or service more severe than originally specified, this Warranty shall become null and void upon date of said change, but only to extent said change affects work covered by this Warranty.
4. The Owner shall promptly notify Roofing Contractor of observed, known or suspected leaks, defect or deterioration, and shall afford reasonable opportunity for Roofing Contractor to inspect work, and to examine evidence of such leaks, defects or deterioration.

5. This Warranty is recognized to be the only Warranty of Roofing Contractor on said work, and is in addition to the Roofing Guarantee furnished by the Roofing Manufacturer, and shall not operate to restrict or cut off Owner from other remedies and resources lawfully available to him in cases of roofing failure. Specifically, this Warranty shall not operate to relieve Roofing Contractor of responsibility for performance of original work in accordance with requirements of the Contract Documents, regardless of whether Contract was a contract directly with Owner or a subcontractor with Owner's General Contractor.

IN WITNESS THEREOF, this instrument has been dully executed this:

Day of, _____, 20_____

Cosigned by Construction Manager By:

(Construction Manager)

(Roofing Contractor)

(Business Address)

(Business Address)

(Signature)

(Signature)

(Title)

(Title)

THIS PAGE INTENTIONALLY BLANK

SECTION 076200 - SHEET METAL FLASHING AND TRIM

PART 1 - GENERAL

1.1 RELATED DOCUMENTS

- A. Drawings and general provisions of the Contract, including General and Supplementary Conditions and Division 01 Specification Sections, apply to this Section.

1.2 SUMMARY

- A. Section Includes:

- 1. Manufactured Products:
 - a. Manufactured reglets and counter flashings.
- 2. Formed Products:
 - a. Formed roof flashings.
 - b. Formed equipment support flashings.
 - c. Formed parapet copings and flashings.

1.3 PERFORMANCE REQUIREMENTS

- A. General: Sheet metal flashing and trim assemblies as indicated shall withstand wind loads, structural movement, thermally induced movement, and exposure to weather without failure due to defective manufacture, fabrication, installation, or other defects in construction. Completed sheet metal flashing and trim shall not rattle, leak, or loosen, and shall remain watertight.
- B. Thermal Movements: Provide sheet metal flashing and trim that allows for thermal movements from ambient and surface temperature changes.
 - 1. Temperature Change (Range): 120 deg F (67 deg C), ambient; 180 deg F (100 deg C), material surfaces.

1.4 SUBMITTALS

- A. Product Data: For each type of product indicated. Include construction details, material descriptions, dimensions of individual components and profiles, and finishes for each manufactured product and accessory, including prefinished metal materials.
- B. Samples for Selection: For each type of sheet metal flashing, trim, and accessory indicated with factory-applied color finishes involving color selection, 1'-0" x 1'-0" size samples of requested colors.

- C. Qualification Data: For qualified fabricator.

1.5 QUALITY ASSURANCE

- A. Fabricator Qualifications: Shop that employs skilled workers who custom fabricate sheet metal flashing and trim similar to that required for this Project and whose products have a record of successful in-service performance.
- B. Sheet Metal Flashing and Trim Standard: Comply with Sheet Metal and Air Conditioning Contractors National Association's (SMACNA) "Architectural Sheet Metal Manual" unless more stringent requirements are specified or shown on Drawings.

1.6 DELIVERY, STORAGE, AND HANDLING

- A. Do not store sheet metal flashing and trim materials in contact with other materials that might cause staining, denting, or other surface damage. Store sheet metal flashing and trim materials away from uncured concrete and masonry.
- B. Protect strippable protective covering on sheet metal flashing and trim from exposure to sunlight and high humidity, except to the extent necessary for the period of sheet metal flashing and trim installation.

1.7 WARRANTY

- A. Special Warranty on Finishes: Manufacturer's standard form in which manufacturer agrees to repair finish or replace sheet metal flashing and trim that shows evidence of deterioration of factory-applied finishes within specified warranty period.
 - 1. Exposed Panel Finish: Deterioration includes, but is not limited to, the following:
 - a. Color fading more than 5 Hunter units when tested according to ASTM D 2244.
 - b. Chalking in excess of a No. 8 rating when tested according to ASTM D 4214.
 - c. Cracking, checking, peeling, or failure of paint to adhere to bare metal.
 - 2. Finish Warranty Period: 20 years from date of Substantial Completion.

PART 2 - PRODUCTS

2.1 SHEET METALS

- A. General: Protect mechanical and other finishes on exposed surfaces from damage by applying a strippable, temporary protective film before shipping.
- B. Metallic-Coated Steel Sheet: Restricted flatness steel sheet, metallic coated by the hot-dip process and pre-painted by the coil-coating process to comply with ASTM A 755/A 755M.

1. Zinc-Coated (Galvanized) Steel Sheet: ASTM A 653/A 653M, G90 (Z275) coating designation; structural quality.
2. Aluminum-Zinc Alloy-Coated Steel Sheet: ASTM A 792/A 792M, Class AZ50 coating designation, Grade 40 (Class AZM150 coating designation, Grade 275); structural quality.
3. Surface: Smooth, flat
4. Exposed Coil-Coated Finish: (Prefinished Steel):
 - a. Two-Coat Fluoropolymer: AAMA 621. Fluoropolymer finish containing not less than 70 percent PVDF resin by weight in color coat. Prepare, pretreat, and apply coating to exposed metal surfaces to comply with coating and resin manufacturers' written instructions, or
 - b. Three-Coat Fluoropolymer: AAMA 621. Fluoropolymer finish containing not less than 70 percent PVDF resin by weight in both color coat and clear topcoat. Prepare, pretreat, and apply coating to exposed metal surfaces to comply with coating and resin manufacturers' written instructions.
5. Color for prefinished steel: Selected by Architect from a full range of colors.
6. TPO coated metal shall be as specified in Specifications Section 075423.

2.2 UNDERLAYMENT MATERIALS

- A. Felt: ASTM D 226, Type II (No. 30), asphalt-saturated organic felt, nonperforated.
- B. Self-Adhering, High-Temperature Sheet: Minimum 30 to 40 mils (0.76 to 1.0 mm) thick, consisting of slip-resisting polyethylene-film top surface laminated to layer of butyl or SBS-modified asphalt adhesive, with release-paper backing; cold applied. Provide primer when recommended by underlayment manufacturer.
 1. Thermal Stability: ASTM D 1970; stable after testing at 240 deg F (116 deg C).
 2. Low-Temperature Flexibility: ASTM D 1970; passes after testing at minus 20 deg F (29 deg C).
 3. Products: Subject to compliance with requirements, provide one of the following:
 - a. Carlisle Coatings & Waterproofing Inc.; CCW WIP 300HT.
 - b. Grace Construction Products, a unit of W. R. Grace & Co.; Ultra.
 - c. Owens Corning; WeatherLock Metal High Temperature Underlayment.
- C. Slip Sheet: Building paper, 3-lb/100 sq. ft. (0.16-kb/sq. m) minimum, rosin sized.

2.3 MISCELLANEOUS MATERIALS

- A. General: Provide materials and types of fasteners, solder, welding rods, protective coatings, separators, sealants, and other miscellaneous items as required for complete sheet metal flashing and trim installation and recommended by manufacturer of primary sheet metal or manufactured item unless otherwise indicated.

- B. Fasteners: Wood screws, annular threaded nails, self-tapping screws, self-locking rivets and bolts, and other suitable fasteners designed to withstand design loads and recommended by manufacturer of primary sheet metal or manufactured item.
 - 1. General: Blind fasteners or self-drilling screws, gasketed, with hex-washer head.
 - a. Exposed Fasteners: Heads matching color of sheet metal using plastic caps or factory-applied coating.
 - b. Blind Fasteners: High-strength aluminum or stainless-steel rivets suitable for metal being fastened.
 - 2. Fasteners for Zinc-Coated (Galvanized) or Aluminum-Zinc Alloy-Coated Steel Sheet: Hot-dip galvanized steel according to ASTM A 153/A 153M or ASTM F 2329 or Series 300 stainless steel.
- C. Solder:
 - 1. For Zinc-Coated (Galvanized) Steel: ASTM B 32, Grade Sn50, 50 percent tin and 50 percent lead or Grade Sn60, 60 percent tin and 40 percent lead.
- D. Sealant Tape: Pressure-sensitive, 100 percent solids, gray polyisobutylene compound sealant tape with release-paper backing. Provide permanently elastic, nonsag, nontoxic, nonstaining tape 1/2 inch (13 mm) wide and 1/8 inch (3 mm) thick.
- E. Elastomeric Sealant: ASTM C 920, elastomeric polyurethane polymer sealant; low modulus; of type, grade, class, and use classifications required to seal joints in sheet metal flashing and trim and remain watertight.
- F. Butyl Sealant: ASTM C 1311, single-component, solvent-release butyl rubber sealant; polyisobutylene plasticized; heavy bodied for hooked-type expansion joints with limited movement.
- G. Bituminous Coating: Cold-applied asphalt emulsion complying with ASTM D 1187.
- H. Asphalt Roofing Cement: ASTM D 4586, asbestos free, of consistency required for application.

2.4 FABRICATION, GENERAL

- A. General: Custom fabricate sheet metal flashing, trim, and roof drainage items to comply with recommendations in SMACNA's "Architectural Sheet Metal Manual" that apply and to design, dimensions, geometry, metal thickness, and other characteristics of item indicated on the Drawings. Fabricate items at the shop to greatest extent possible.
 - 1. Fabricate sheet metal flashing and trim in thickness or weight needed to comply with performance requirements, but not less than that indicated for each application.
 - 2. Obtain field measurements for accurate fit before shop fabrication.
 - 3. Form sheet metal flashing and trim without excessive oil canning, buckling, and tool marks and true to line and levels indicated, with exposed edges folded back to form hems.

4. Conceal fasteners and expansion provisions where possible. Exposed fasteners are not allowed on faces exposed to view.
- B. Fabrication Tolerances: Fabricate sheet metal flashing and trim that is capable of installation to a tolerance of 1/4 inch in 20 feet (6 mm in 6 m) on slope and location lines as indicated and within 1/8-inch (3-mm) offset of adjoining faces and of alignment of matching profiles.
- C. Sealed Joints: Form non-expansion but movable joints in metal to accommodate elastomeric sealant.
- D. Expansion Provisions: Where lapped expansion provisions cannot be used, form expansion joints of intermeshing hooked flanges, not less than 1 inch (25 mm) deep, filled with butyl sealant concealed within joints.
- E. Fabricate cleats and attachment devices from same material as accessory being anchored or from compatible, noncorrosive metal.
- F. Seams: Fabricate nonmoving seams in galvanized (non prefinished) steel sheet with flat-lock seams. Tin edges to be seamed, form seams, and solder.
- G. Seams: Fabricate nonmoving seams in prefinished steel sheet with flat-lock seams. Form seams and seal with elastomeric sealant unless otherwise recommended by sealant manufacturer for intended use. Rivet joints where necessary for strength.
- H. Do not use graphite pencils to mark metal surfaces.

PART 3 - EXECUTION

3.1 EXAMINATION

- A. Examine substrates, areas, and conditions, with Installer present, to verify actual locations, dimensions and other conditions affecting performance of the Work.
 1. Verify compliance with requirements for installation tolerances of substrates.
 2. Verify that substrate is sound, dry, smooth, clean, sloped for drainage, and securely anchored.
- B. For the record, prepare written report, endorsed by Installer, listing conditions detrimental to performance of the Work.
- C. Proceed with installation only after unsatisfactory conditions have been corrected.

3.2 UNDERLAYMENT INSTALLATION

- A. General: Install underlayment if and as indicated on Drawings.

3.3 INSTALLATION, GENERAL

- A. General: Anchor sheet metal flashing and trim and other components of the Work securely in place, with provisions for thermal and structural movement. Use fasteners, solder, welding rods, protective coatings, separators, sealants, and other miscellaneous items as required to complete sheet metal flashing and trim system.
1. Install sheet metal flashing and trim true to line and levels indicated. Provide uniform, neat seams with minimum exposure of solder, welds, and sealant.
 2. Install sheet metal flashing and trim to fit substrates and to result in watertight performance. Verify shapes and dimensions of surfaces to be covered before fabricating sheet metal.
 3. Install exposed sheet metal flashing and trim without excessive oil canning, buckling, and tool marks.
 4. Install sealant tape where indicated.
 5. Torch cutting of sheet metal flashing and trim is not permitted.
 6. Do not use graphite pencils to mark metal surfaces.
- B. Metal Protection: Where dissimilar metals will contact each other or corrosive substrates, protect against galvanic action by painting contact surfaces with bituminous coating or by other permanent separation as recommended by SMACNA.
1. Underlayment: Where installing metal flashing directly on cementitious or wood substrates, install a course of felt underlayment and cover with a slip sheet.
- C. Expansion Provisions: Provide for thermal expansion of exposed flashing and trim. Space movement joints at a maximum of 10 feet (3 m) with no joints allowed within 24 inches (600 mm) of corner or intersection. Where lapped expansion provisions cannot be used or would not be sufficiently watertight, form expansion joints of intermeshing hooked flanges, not less than 1 inch (25 mm) deep, filled with sealant concealed within joints.
- D. Seal joints as shown and as required for watertight construction.
- E. Soldered Joints: Clean surfaces to be soldered, removing oils and foreign matter. Pre-tin edges of sheets to be soldered to a width of 1-1/2 inches (38 mm), except reduce pre-tinning where pre-tinned surface would show in completed Work.
- F. Rivets: Rivet joints where indicated and where necessary for strength.

3.4 ROOF, WALL, AND OTHER FLASHING INSTALLATION

- A. General: Install sheet metal flashing and trim to comply with SMACNA's "Architectural Sheet Metal Manual" and as indicated. Provide concealed fasteners where possible, set units true to line, and level as indicated. Install work with laps, joints, and seams that will be permanently watertight and weather resistant.

3.5 ERECTION TOLERANCES

- A. Installation Tolerances: Shim and align sheet metal flashing and trim within installed tolerance of 1/4 inch in 20 feet (6 mm in 6 m) on slope and location lines as indicated and within 1/8-inch (3-mm) offset of adjoining faces and of alignment of matching profiles.

3.6 CLEANING AND PROTECTION

- A. Clean exposed metal surfaces of substances that interfere with uniform oxidation and weathering.
- B. Clean and neutralize flux materials. Clean off excess solder.
- C. Clean off excess sealants.
- D. Remove temporary protective coverings and strippable films as sheet metal flashing and trim are installed unless otherwise indicated in manufacturer's written installation instructions. On completion of installation, remove unused materials and clean finished surfaces. Maintain in a clean condition during construction.
- E. Replace sheet metal flashing and trim that have been damaged or that have deteriorated beyond successful repair by finish touchup or similar minor repair procedures.

END OF SECTION 076200

THIS PAGE INTENTIONALLY BLANK

SECTION 077200 - ROOF ACCESSORIES

PART 1 - GENERAL

1.1 RELATED DOCUMENTS

- A. Drawings and general provisions of the Contract, including General and Supplementary Conditions and Division 01 Specification Sections, apply to this Section.

1.2 SUMMARY

- A. This Section includes the following:
 - 1. Roof hatch.
 - 2. Safety posts, roof ladder and floor door ladder.

1.3 SUBMITTALS

- A. Product Data: For each type of roof accessory indicated. Include construction details, material descriptions, dimensions of individual components and profiles, and finishes.

1.4 DELIVERY, STORAGE, AND HANDLING

- A. Pack, handle, and ship roof accessories properly labeled in heavy-duty packaging to prevent damage.

1.5 COORDINATION

- A. Coordinate layout and installation of roof accessories with interfacing and adjoining construction to provide a leakproof, weathertight, secure, and noncorrosive installation.
 - 1. With Architect's approval, adjust location of roof accessories that would interrupt roof drainage routes.

PART 2 - PRODUCTS

2.1 MANUFACTURERS

- A. Manufacturers: Subject to compliance with requirements, provide products by one of the manufacturers listed in other Part 2 articles.

2.2 ROOF HATCHES

- A. Roof Hatches: Fabricate roof hatches with insulated lid and insulated curb frame with integral deck mounting flange and lid frame counterflashing. Fabricate with welded or mechanically fastened and sealed corner joints. Provide continuous weathertight perimeter gasketing and equip with corrosion-resistant or hot-dip galvanized hardware.
1. Manufacturers:
 - a. Babcock-Davis; a Cierra Products Inc. Company.
 - b. Bilco Company (The).
 - c. Dur-Red Products.
 2. Loads: Fabricate roof hatches to withstand 40-lbf/sq. ft. (1.9-kPa) external and 20-lbf/sq. ft. (0.95-kPa) internal loads.
 3. Type and Size: Single-leaf lid, 36 by 30 inches (750 by 900 mm).
 4. Curb and Lid Material: Galvanized steel sheet, 0.079 inch (2.0 mm) thick.
 - a. Finish: Baked enamel.
 5. Insulation: Glass-fiber board.
 6. Interior Lid Liner: Manufacturer's standard metal liner of same material and finish as outer metal lid.
 7. Exterior Curb Liner: Manufacturer's standard metal liner of same material and finish as metal curb.
 8. Fabricate units to minimum height of 12 inches (300 mm), unless otherwise indicated.
 9. Sloping Roofs: Where slope or roof deck exceeds 1:48, fabricate hatch curbs with height tapered to match slope to level tops of units.
 10. Hardware: Galvanized steel or Stainless-steel spring latch with turn handles, butt- or pintle-type hinge system, and padlock hasps inside and outside.
 11. Ladder Safety Post: Manufacturer's standard ladder safety post. Post to lock in place on full extension. Provide release mechanism to return post to closed position.
 - a. Height: 42 inches (1060 mm) above finished roof deck.
 - b. Material and Finish: Steel tube, galvanized or Steel tube, baked enameled.
 - c. Diameter: Pipe with 1-5/8-inch (41-mm) OD tube.
 12. Fire Rating: Not required.

PART 3 - EXECUTION

3.1 EXAMINATION

- A. Examine substrates, areas, and conditions, with Installer present, to verify actual locations, dimensions, and other conditions affecting performance of work.
1. Verify that substrate is sound, dry, smooth, clean, sloped for drainage, and securely anchored and is ready to receive roof accessories.
 2. Verify dimensions of roof openings for roof accessories.

3. Proceed with installation only after unsatisfactory conditions have been corrected.

3.2 INSTALLATION

- A. General: Install roof accessories according to manufacturer's written instructions. Anchor roof accessories securely in place and capable of resisting forces specified. Use fasteners, separators, sealants, and other miscellaneous items as required for completing roof accessory installation. Install roof accessories to resist exposure to weather without failing, rattling, leaking, and fastener disengagement.
- B. Install roof accessories to fit substrates and to result in watertight performance.
- C. Metal Protection: Where dissimilar metals will contact each other or corrosive substrates, protect against galvanic action by painting contact surfaces with bituminous coating or by other permanent separation as recommended by manufacturer.
- D. Install roof accessories level, plumb, true to line and elevation, and without warping, jogs in alignment, excessive oil canning, buckling, or tool marks.
- E. Roof Hatch Installation:
 1. Check roof hatch for proper operation. Adjust operating mechanism as required. Clean and lubricate joints and hardware.
 2. Attach ladder safety post according to manufacturer's written instructions.

3.3 CLEANING

- A. Clean exposed surfaces according to manufacturer's written instructions.

END OF SECTION 077200

THIS PAGE INTENTIONALLY BLANK

SECTION 078413 - PENETRATION FIRESTOPPING

PART 1 - GENERAL

1.1 RELATED DOCUMENTS

- A. Drawings and general provisions of the Contract, including General and Supplementary Conditions and Division 01 Specification Sections, apply to this Section.

1.2 SUMMARY

- A. This Section includes through-penetration firestop systems for penetrations through fire-resistance-rated constructions, including both empty openings and openings containing penetrating items.

1.3 PERFORMANCE REQUIREMENTS

- A. General: For penetrations through fire-resistance-rated constructions, including both empty openings and openings containing penetrating items, provide through-penetration firestop systems that are produced and installed to resist spread of fire according to requirements indicated, resist passage of smoke and other gases, and maintain original fire-resistance rating of construction penetrated.
 - 1. Fire-resistance-rated walls including fire walls.
- B. Rated Systems: Provide through-penetration firestop systems with the following ratings determined per ASTM E 814 or UL 1479:
 - 1. F-Rated Systems: Provide through-penetration firestop systems with F-ratings indicated, but not less than that equaling or exceeding fire-resistance rating of constructions penetrated.
 - 2. T-Rated Systems: For the following conditions, provide through-penetration firestop systems with T-ratings indicated, as well as F-ratings, where systems protect penetrating items exposed to potential contact with adjacent materials in occupiable floor areas:
 - a. Penetrations located outside wall cavities.
 - b. Penetrations located outside fire-resistance-rated shaft enclosures.
- C. For through-penetration firestop systems exposed to view, traffic, moisture, and physical damage, provide products that, after curing, do not deteriorate when exposed to these conditions both during and after construction.
 - 1. For piping penetrations for plumbing and wet-pipe sprinkler systems, provide moisture-resistant through-penetration firestop systems.

2. For penetrations involving insulated piping, provide through-penetration firestop systems not requiring removal of insulation.
- D. For through-penetration firestop systems exposed to view, provide products with flame-spread and smoke-developed indexes of less than 25 and 450, respectively, as determined per ASTM E 84.

1.4 SUBMITTALS

- A. Product Data: For each type of product indicated.
- B. Shop Drawings: For each through-penetration firestop system, show each type of construction condition penetrated, relationships to adjoining construction, and type of penetrating item. Include firestop design designation of qualified testing and inspecting agency that evidences compliance with requirements for each condition indicated.
1. Submit documentation, including illustrations, from a qualified testing and inspecting agency that is applicable to each through-penetration firestop system configuration for construction and penetrating items.
 2. Where Project conditions require modification to a qualified testing and inspecting agency's illustration for a particular through-penetration firestop condition, submit illustration, with modifications marked, approved by through-penetration firestop system manufacturer's fire-protection engineer as an engineering judgment or equivalent fire-resistance-rated assembly.
- C. Through-Penetration Firestop System Schedule: Indicate locations of each through-penetration firestop system, along with the following information:
1. Types of penetrating items.
 2. Types of constructions penetrated, including fire-resistance ratings and, where applicable, thicknesses of construction penetrated.
 3. Through-penetration firestop systems for each location identified by firestop design designation of qualified testing and inspecting agency.
- D. Qualification Data: For Installer.

1.5 QUALITY ASSURANCE

- A. Installer Qualifications: A firm experienced in installing through-penetration firestop systems similar in material, design, and extent to that indicated for this Project, whose work has resulted in construction with a record of successful performance.
- B. Source Limitations: Obtain through-penetration firestop systems, for each kind of penetration and construction condition indicated, through one source from a single manufacturer.

1.6 DELIVERY, STORAGE, AND HANDLING

- A. Deliver through-penetration firestop system products to Project site in original, unopened containers or packages with intact and legible manufacturers' labels identifying product and

manufacturer, date of manufacture, lot number, shelf life if applicable, qualified testing and inspecting agency's classification marking applicable to Project, curing time, and mixing instructions for multicomponent materials.

- B. Store and handle materials for through-penetration firestop systems to prevent their deterioration or damage due to moisture, temperature changes, contaminants, or other causes.

1.7 PROJECT CONDITIONS

- A. Environmental Limitations: Do not install through-penetration firestop systems when ambient or substrate temperatures are outside limits permitted by through-penetration firestop system manufacturers or when substrates are wet due to rain, frost, condensation, or other causes.
- B. Ventilate through-penetration firestop systems per manufacturer's written instructions by natural means or, where this is inadequate, forced-air circulation.

1.8 COORDINATION

- A. Coordinate construction of openings and penetrating items to ensure that through-penetration firestop systems are installed according to specified requirements.
- B. Coordinate sizing of sleeves, openings, core-drilled holes, or cut openings to accommodate through-penetration firestop systems.
- C. Notify Owner's inspecting agency at least seven days in advance of through-penetration firestop system installations; confirm dates and times on days preceding each series of installations.
- D. Do not cover up through-penetration firestop system installations that will become concealed behind other construction until each installation has been examined by Owner's inspecting agency and building inspector, if required by authorities having jurisdiction.

PART 2 - PRODUCTS

2.1 MANUFACTURERS / SYSTEMS

- A. Products: Subject to compliance with requirements, provide the through-penetration firestop systems indicated for each application in Firestopping Appendix A of the Project Manual. Systems by other Manufacturers are subject to approval by the Architect prior to bidding.

2.2 FIRESTOPPING, GENERAL

- A. Compatibility: Provide through-penetration firestop systems that are compatible with one another; with the substrates forming openings; and with the items, if any, penetrating through-penetration firestop systems, under conditions of service and application, as demonstrated by through-penetration firestop system manufacturer based on testing and field experience.

- B. Accessories: Provide all components for each through-penetration firestop system that are needed to provide a complete firestopping assembly. Use only components specified by through-penetration firestop system manufacturer and approved by qualified testing and inspecting agency for firestop systems indicated.

PART 3 - EXECUTION

3.1 EXAMINATION

- A. Examine substrates and conditions, with Installer present, for compliance with requirements for opening configurations, penetrating items, substrates, and other conditions affecting performance of work.
 - 1. Proceed with installation only after unsatisfactory conditions have been corrected.

3.2 PREPARATION

- A. Surface Cleaning: Clean out openings immediately before installing through-penetration firestop systems to comply with firestop system manufacturer's written instructions and with the following requirements:
 - 1. Remove from surfaces of opening substrates and from penetrating items foreign materials that could interfere with adhesion of through-penetration firestop systems.
 - 2. Clean opening substrates and penetrating items to produce clean, sound surfaces capable of developing optimum bond with through-penetration firestop systems. Remove loose particles remaining from cleaning operation.
- B. Priming: Prime substrates where recommended in writing by through-penetration firestop system manufacturer using that manufacturer's recommended products and methods. Confine primers to areas of bond; do not allow spillage and migration onto exposed surfaces.
- C. Masking Tape: Use masking tape to prevent through-penetration firestop systems from contacting adjoining surfaces that will remain exposed on completion of Work and that would otherwise be permanently stained or damaged by such contact or by cleaning methods used to remove smears from firestop system materials. Remove tape as soon as possible without disturbing firestop system's seal with substrates.

3.3 THROUGH-PENETRATION FIRESTOP SYSTEM INSTALLATION

- A. General: Install through-penetration firestop systems to comply with Part 1 "Performance Requirements" Article and with firestop system manufacturer's written installation instructions and published drawings for products and applications indicated.
- B. Install forming/damming/backing materials and other accessories of types required to support fill materials during their application and in the position needed to produce cross-sectional shapes and depths required to achieve fire ratings indicated.

1. After installing fill materials and allowing them to fully cure, remove combustible forming materials and other accessories not indicated as permanent components of firestop systems.
- C. Install fill materials for firestop systems by proven techniques to produce the following results:
1. Fill voids and cavities formed by openings, forming materials, accessories, and penetrating items as required to achieve fire-resistance ratings indicated.
 2. Apply materials so they contact and adhere to substrates formed by openings and penetrating items.
 3. For fill materials that will remain exposed after completing Work, finish to produce smooth, uniform surfaces that are flush with adjoining finishes.

3.4 IDENTIFICATION

- A. Identify fire rated walls containing penetration firestopping systems with permanent, painted or preprinted metal or plastic labels with the words "FIRE AND/OR SMOKE BARRIER – PROTECT ALL OPENINGS" using lettering not less than 3 inches in height with minimum 0.375-inch strokes. Locate text on wall in accessible ceiling and attic spaces at maximum 30-foot intervals and no more than 15-feet from ends of wall.
- B. Identify through-penetration firestop systems with preprinted metal or plastic labels. Attach labels permanently to surfaces adjacent to and within 6 inches (150 mm) of edge of the firestop systems so that labels will be visible to anyone seeking to remove penetrating items or firestop systems. Use mechanical fasteners for metal labels. For plastic labels, use self-adhering type with adhesives capable of permanently bonding labels to surfaces on which labels are placed and, in combination with label material, will result in partial destruction of label if removal is attempted. Include the following information on labels:
1. The words "Warning - Through-Penetration Firestop System - Do Not Disturb. Notify Building Management of Any Damage."
 2. Contractor's name, address, and phone number.
 3. Through-penetration firestop system designation of applicable testing and inspecting agency.
 4. Date of installation.
 5. Through-penetration firestop system manufacturer's name.
 6. Installer's name.

3.5 FIELD QUALITY CONTROL

- A. Inspecting Agency: Owner may engage a qualified, independent inspecting agency to inspect through-penetration firestops. Independent inspecting agency shall comply with ASTM E 2174 requirements including those related to qualifications, conducting inspections, and preparing test reports.
- B. Where deficiencies are found, repair or replace through-penetration firestop systems so they comply with requirements.

- C. Proceed with enclosing through-penetration firestop systems with other construction only after inspection reports are issued and firestop installations comply with requirements.

3.6 CLEANING AND PROTECTING

- A. Clean off excess fill materials adjacent to openings as Work progresses by methods and with cleaning materials that are approved in writing by through-penetration firestop system manufacturers and that do not damage materials in which openings occur.
- B. Provide final protection and maintain conditions during and after installation that ensure that through-penetration firestop systems are without damage or deterioration at time of Substantial Completion. If, despite such protection, damage or deterioration occurs, cut out and remove damaged or deteriorated through-penetration firestop systems immediately and install new materials to produce systems complying with specified requirements.

3.7 FIRESTOPPING SYSTEM ASSEMBLIES

- A. Provide firestopping systems for various penetrating items through various construction in accordance with the requirements of the Firestopping System Schedule contained in the following Firestopping Appendix A.
 - 1. Firestopping systems assemblies other than those given in the following Firestopping System Schedule are subject to approval prior to bidding.

END OF SECTION 078413

SECTION 078413 – FIRESTOPPING APPENDIX A

FIRESTOPPING SYSTEM SCHEDULE

Provide firestopping systems for various penetrating items through various constructions in accordance with the following schedule and system sheets AP-A-2 through AP-A-7.

<u>Type of Construction</u>	<u>Penetrating Item</u>	<u>UL/WHI Rating</u>	<u>*Metacaulk System Detail</u>	
-----------------------------	-------------------------	----------------------	---------------------------------	--

FOR USE IN DRY AREAS, NON-MOVING PENETRATING ITEMS:

MU	SP	F-2 hr.	950CW-25	AP-B-2
	EMT	F-2 hr.	950CW-35	AP-B-3
	CP	F-2 hr.	950CW-26	AP-B-4

GW	SP	F-2 hr.	950GW-5	AP-B-5
	EMT	F-2 hr.	950GW-35	AP-B-6
	CP	F-2 hr.	950GW-26	AP-B-7

ABBREVIATIONS:

MU - Concrete Masonry or Clay Brick Masonry Units
GW – Gypsum Board
SP – Steel Pipe
EMT – Conduit
CP – Copper Pipe

* Products by other manufacturers are subject to approval prior to bidding.



System No.
WJ1013
(formerly 442)

metacaulk®

950CW-25
Wall Penetration
2 Hour Rating

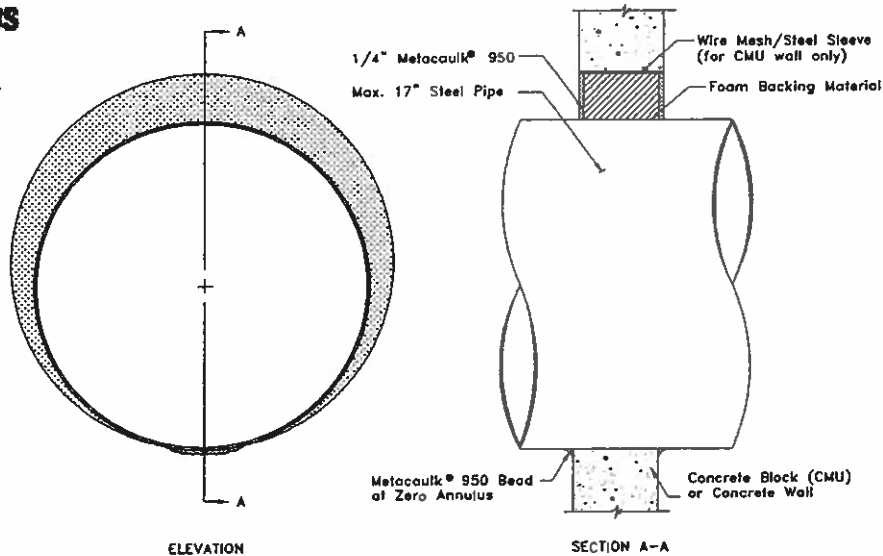

SYSTEM CONFIGURATION INFORMATION

METACAULK® PRODUCT(S)			PENETRATING ITEM(S)			HOLE SIZE	ANNULAR SPACING			ADDITIONAL INSTALLATION MATERIALS AND AIDS			BACKING MATERIAL		ASTM E 814 RATING	
FILL MAT'L	MIN. THICK.	OTHER	TYPE	SIZE	INSULATION	MAX.	MIN.	MAX.	WIRE MESH	STEEL SLEEVE	OTHER	TYPE	DEPTH	T	F	
950	1/4" both sides	none	steel pipe, 0.125" wall thickness (or heavier)	up to 17 1/4" O.D.	none	22 3/4"	0"	2 3/4"	No.8 steel wire cloth (for CMU wall only)	minimum 20 gauge galvanized steel	none	foam backer rod	full wall	0:15	2	

INSTALLATION INSTRUCTIONS

These instructions are for the installation of through-penetration fire stop system 950CW-25 in minimum 4 1/2 inch thick lightweight or normal weight (100-150 pcf) concrete walls or concrete block (CMU) walls as listed by Underwriters Laboratories Inc. Refer to above drawings and System Configuration Information for component details.

Step Procedure

- Cut hole in concrete block (CMU) or concrete wall in required size to accommodate pipe penetration and allowable annular spacing. Do not exceed maximum specified hole diameter.
- Install up to 17 1/2 inch O.D. steel pipe. Support pipe rigidly on both sides of wall.
- Where needed to aid in system installation in concrete block (CMU) walls, specified wire mesh or galvanized steel sleeve may be cut to size, formed to hole shape, centered inside wall around pipe, and allowed to spring back snugly against periphery of hole such that it is recessed a minimum of 1/2 inch in from wall surface on both sides.
- Clean all hole and pipe surfaces in penetration area to remove loose debris, dirt, oil, wax, grease, old caulking, etc.
- Install backing material by firmly packing annular space with full wall depth of specified foam backer rod. Recess backing material at least 1/4 inch in from both sides of wall to accommodate the required fill depth of Metacaulk® 950.
- Gun, trowel and/or pump Metacaulk® 950 firestopping sealant to a minimum 1/4 inch depth on both sides of wall. Trowel sealant surfaces flush with wall surfaces and to a smooth defect-free finish. Apply 1/2 inch diameter caulking bead along all zero annular contact areas on both sides of wall and tool smooth.

JOB NAME:

ARCHITECT:

CUSTOMER:

CUSTOMER ORDER NO:

CONTRACTOR:

REPRESENTATIVE:

REPRESENTATIVE ORDER NO:

THE RECTORSEAL CORPORATION
2601 SPENWICK HOUSTON, TEXAS 77055

REVISION NUMBER:

SHEET NUMBER:

OF AP-B-2



System No.
WJ1019
(formerly 552)

metacaulk®

950CW-35
Wall Penetration
2 Hour Rating

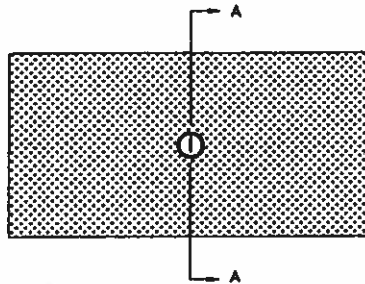

ELEVATION

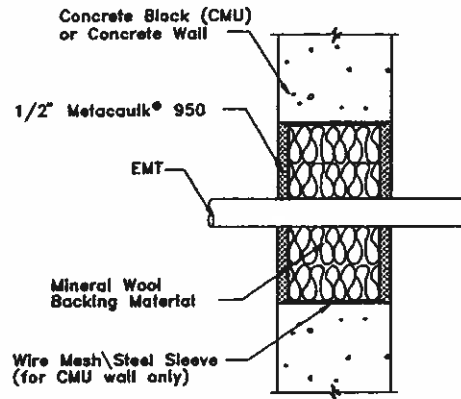

SECTION A-A

SYSTEM CONFIGURATION INFORMATION																
METACAULK® PRODUCT(S)			PENETRATING ITEM(S)			HOLE SIZE	ANNULAR SPACING			ADDITIONAL INSTALLATION MATERIALS AND AIDS			BACKING MATERIAL		ASTM E 814 RATING	
FILL MAT'L	MIN. THICK.	OTHER	TYPE	SIZE	INSULATION	MAX.	MIN.	MAX.	WIRE MESH	STEEL SLEEVE	OTHER	TYPE	DEPTH	T	F	
950	1/2" both sides	none	EMT	up to 7	none	16" L or W and 128 sqin.	3 1/2"	11 5/16"	No. 8 steel wire cloth (for CMU wall only)	minimum 20 gauge galvanized steel	none	minimum 4.0 pcf mineral wool	full wall	1:30	2	

INSTALLATION INSTRUCTIONS

These instructions are for the installation of through-penetration fire stop system 950CW-35 in minimum 4 1/2 inch thick lightweight or normal weight (100-150 pcf) concrete walls or concrete block (CMU) walls as listed by Underwriters Laboratories Inc. Refer to above drawings and System Configuration Information for component details.

Step Procedure

- 1 Cut hole in concrete block (CMU) or concrete wall in required size to accommodate EMT penetration and allowable annular spacing. Do not exceed maximum specified hole dimensions and area.
- 2 Install up to (7) 1 inch I.D. EMT. Support EMT rigidly on both sides of wall.
- 3 Where needed to aid in system installation in concrete block (CMU) walls, specified wire mesh or galvanized steel sleeve may be cut to size, formed to hole shape, centered inside wall around EMT, and allowed to spring back snugly against periphery of hole such that it is recessed a minimum of 1/2 inch in from wall surface on both sides.
- 4 Clean all hole and EMT surfaces in penetration area to remove loose debris, dirt, oil, wax, grease, old caulking, etc.
- 5 Install backing material by firmly packing annular space with full wall depth of specified mineral wool. Recess backing material at least 1/2 inch in from both sides of wall to accommodate the required fill depth of Metacaulk® 950.
- 6 Gun, trowel and/or pump Metacaulk® 950 firestopping sealant to a minimum 1/2 inch depth on both sides of wall. Trowel sealant surfaces flush with wall surfaces and to a smooth defect-free finish.

JOB NAME:

ARCHITECT:

CUSTOMER:

CUSTOMER ORDER NO:

CONTRACTOR:

REPRESENTATIVE:

REPRESENTATIVE ORDER NO:

THE RECTOR SEAL CORPORATION
2601 SPENWICK HOUSTON, TEXAS 77055

REVISION NUMBER:

SHEET NUMBER:

OF AP-B-3



metacaulk®

950CW-26
Wall Penetration
2 Hour Rating

System No.
WJ1013
(formerly 442)

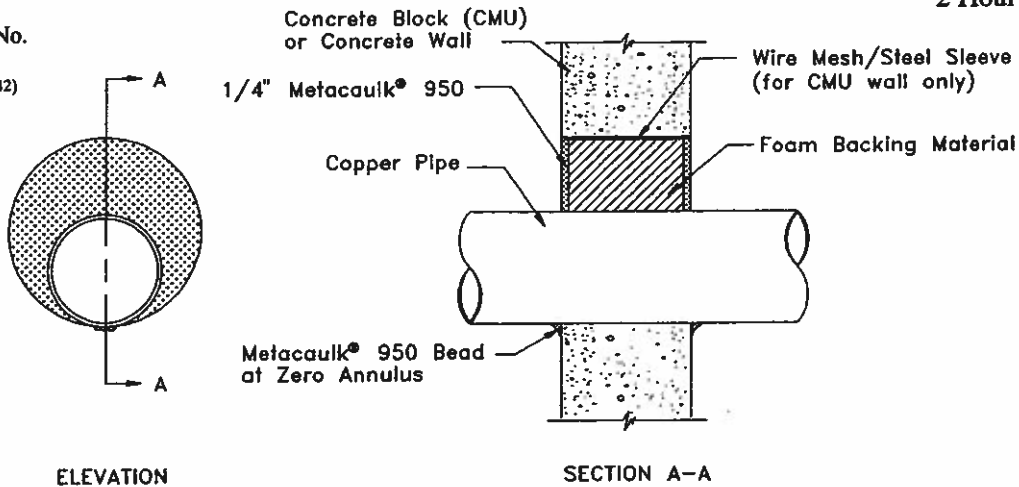

SYSTEM CONFIGURATION INFORMATION

METACAULK® PRODUCT(S)			PENETRATING ITEM(S)			HOLE SIZE	ANNULAR SPACING			ADDITIONAL INSTALLATION MATERIALS AND AIDS			BACKING MATERIAL		ASTM E 814 RATING	
FILL MAT'L	MIN. THICK.	OTHER	TYPE	SIZE	INSULATION	MAX.	MIN.	MAX.	WIRE MESH	STEEL SLEEVE	OTHER	TYPE	DEPTH	T	F	
950	1/4" both sides	none	copper pipe, Type L (or heavier)	up to 4" I.D.	none	10 1/8"	0"	3"	No. 8 steel wire cloth (for CMU wall only)	minimum 20 gauge galvanized steel	none	foam backer rod	full wall	0	2	

INSTALLATION INSTRUCTIONS

These instructions are for the installation of through-penetration fire stop system 950CW-26 in minimum 4 1/2 inch thick lightweight or normal weight (100-150 pcf) concrete walls or concrete block (CMU) walls as listed by Underwriters Laboratories Inc. Refer to above drawings and System Configuration Information for component details.

Step Procedure

- 1 Cut hole in concrete block (CMU) or concrete wall in required size to accommodate pipe penetration and allowable annular spacing. Do not exceed maximum specified hole diameter.
- 2 Install up to 4 inch I.D. copper pipe. Support pipe rigidly on both sides of wall.
- 3 Where needed to aid in system installation in concrete block (CMU) walls, specified wire mesh or galvanized steel sleeve may be cut to size, formed to hole shape, centered inside wall around pipe, and allowed to spring back snugly against periphery of hole such that it is recessed a minimum of 1/2 inch in from wall surface on both sides.
- 4 Clean all hole and pipe surfaces in penetration area to remove loose debris, dirt, oil, wax, grease, old caulking, etc.
- 5 Install backing material by firmly packing annular space with full wall depth of specified foam backer rod. Recess backing material at least 1/4 inch in from both sides of wall to accommodate the required fill depth of Metacaulk® 950.
- 6 Gun, trowel and/or pump Metacaulk® 950 firestopping sealant to a minimum 1/4 inch depth on both sides of wall. Trowel sealant surfaces flush with wall surfaces and to a smooth defect-free finish. Apply 1/2 inch diameter caulking bead along all zero annular contact areas on both sides of wall and tool smooth.

JOB NAME:

ARCHITECT:

CUSTOMER:

CUSTOMER ORDER NO:

CONTRACTOR:

REPRESENTATIVE:

REPRESENTATIVE ORDER NO:

THE RECTORSEAL CORPORATION
2601 SPENWICK HOUSTON, TEXAS 77055

REVISION NUMBER:

SHEET NUMBER:

OF AP-B-4

metacaulk®



System No.
WL1040
(formerly 256)



TRC/PV 120-08

950GW-5
Wall Penetration
2 Hour Rating

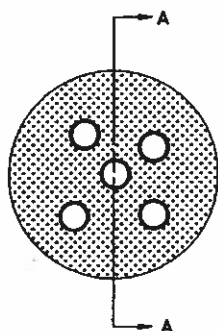

ELEVATION

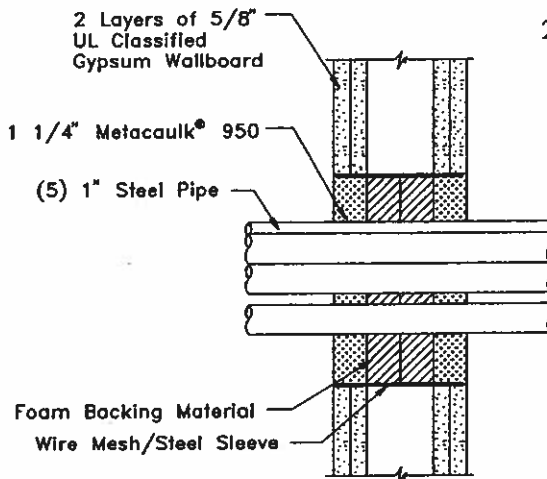

SECTION A-A

SYSTEM CONFIGURATION INFORMATION

METACAULK® PRODUCT(S)			PENETRATING ITEM(S)			HOLE SIZE	ANNULAR SPACING			ADDITIONAL INSTALLATION MATERIALS AND AIDS			BACKING MATERIAL		ASTM E 814 RATING	
FILL MAT'L	MIN. THICK.	OTHER	TYPE	SIZE	INSULATION	MAX.	MIN.	MAX.	WIRE MESH	STEEL SLEEVE	OTHER	TYPE	DEPTH	T	F	
950	1 1/4" both sides	none	steel pipe, SCH 40 (or heavier)	*up to 5-1" I.D.	none	8"	1 1/2"	1 1/2"	No. 8 steel wire cloth	minimum 20 gauge galvanized steel	none	foam backer rod	min. 1 1/4" both sides	1:30	2	

* with minimum 3/8" spacing between adjacent pipe.

INSTALLATION INSTRUCTIONS

These instructions are for the installation of through-penetration fire stop system 950GW-5 in minimum 5 inch thick steel or wood stud fire rated gypsum wallboard partitions as listed by Underwriters Laboratories Inc. Refer to above drawings and System Configuration Information for component details.

Step Procedure

- 1 Cut hole in gypsum wallboard in required size to accommodate pipe penetration(s) and allowable annular spacing. Do not exceed maximum specified hole diameter.
- 2 Install up to 5 - 1 inch I.D. steel pipe. Support pipe rigidly on both sides of wall. Allow for required minimum spacing between pipe.
- 3 Clean all hole and pipe surfaces in penetration area to remove loose debris, dirt, oil, wax, grease, old caulking, etc.
- 4 Install specified wire mesh or galvanized steel sleeve cut to size, formed to hole shape, centered inside wall around pipe, and allowed to spring back snugly against periphery of hole such that it is recessed a minimum of 1/2 inch in from wall surface on both sides.
- 5 Install backing material by firmly packing annular space with at least 1 1/4 inches of specified foam backer rod from both sides of wall. Recess backing material at least 1 1/4 inches in from both sides of wall to accommodate the required fill depth of Metacaulk® 950.
- 6 Gun, trowel and/or pump Metacaulk® 950 firestopping sealant to a minimum 1 1/4 inch depth on both sides of wall. Trowel sealant surfaces flush with wall surfaces and to a smooth defect-free finish.

JOB NAME:

ARCHITECT:

CUSTOMER:

CUSTOMER ORDER NO:

CONTRACTOR:

REPRESENTATIVE:

REPRESENTATIVE ORDER NO:

THE RECTOR SEAL CORPORATION
2601 SPENWICK HOUSTON, TEXAS 77055

OUR NUMBER:
SHEET NUMBER:

OF AP-B-5



System No.
WL1035
(formerly 552)

metacaulk®

950GW-35
Wall Penetration
2 Hour Rating

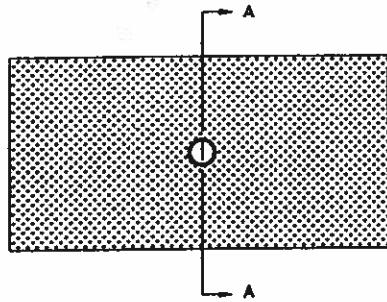

ELEVATION

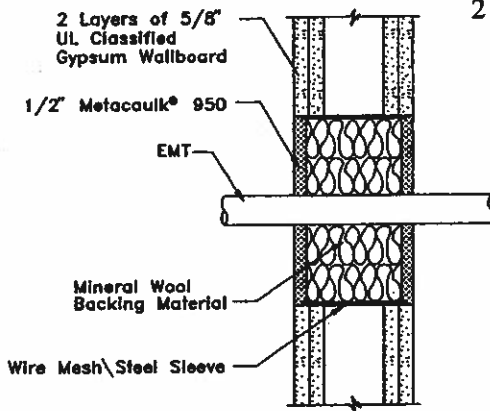

SECTION A-A

SYSTEM CONFIGURATION INFORMATION

METACAULK® PRODUCT(S)			PENETRATING ITEM(S)			HOLE SIZE	ANNULAR SPACING		ADDITIONAL INSTALLATION MATERIALS AND AIDS			BACKING MATERIAL		ASTM E 814 RATING	
FILL MAT'L	MIN. THICK.	OTHER	TYPE	SIZE	INSULATION	MAX.	MIN.	MAX.	WIRE MESH	STEEL SLEEVE	OTHER	TYPE	DEPTH	T	F
950	1/2" both sides	none	EMT	up to 7	none	16" L or W and 128 sqin.	3 1/2"	11 5/16"	No.8 steel wire cloth	minimum 20 gauge galvanized steel	none	minimum 4.0 pcf mineral wool	full wall	1:30	2

INSTALLATION INSTRUCTIONS

These instructions are for the installation of through-penetration fire stop system 950GW-35 in minimum 5 inch thick steel or wood stud fire rated gypsum wallboard partitions as listed by Underwriters Laboratories Inc. Refer to above drawings and System Configuration Information for component details.

Step Procedure

- 1 Cut hole in gypsum wallboard in required size to accommodate EMT penetration and allowable annular spacing. Do not exceed maximum specified hole dimensions and area.
- 2 Install up to (7) 1 inch I.D. EMT. Support EMT rigidly on both sides of wall.
- 3 Install specified wire mesh or galvanized steel sleeve cut to size, formed to hole shape, centered inside wall around EMT, and allowed to spring back snugly against periphery of hole such that it is recessed a minimum of 1/8 inch in from wall surface on both sides.
- 4 Clean all hole and EMT surfaces in penetration area to remove loose debris, dirt, oil, wax, grease, old caulking, etc.
- 5 Install backing material by firmly packing annular space with full wall depth of specified mineral wool. Recess backing material at least 1/2 inch in from both sides of wall to accommodate the required fill depth of Metacaulk® 950.
- 6 Gun, trowel and/or pump Metacaulk® 950 firestopping sealant to a minimum 1/2 inch depth on both sides of wall. Trowel sealant surfaces flush with wall surfaces and to a smooth defect-free finish.

JOB NAME:

ARCHITECT:

CUSTOMER:

CUSTOMER ORDER NO:

CONTRACTOR:

REPRESENTATIVE:

REPRESENTATIVE ORDER NO:

THE RECTORSEAL CORPORATION
2601 SPENWICK HOUSTON, TEXAS 77055

REVISION NUMBER:

SHEET NUMBER:

OF AP-B-6



System No.
WL1026
(formerly 442)

metacaulk®

950GW-26
Wall Penetration
2 Hour Rating

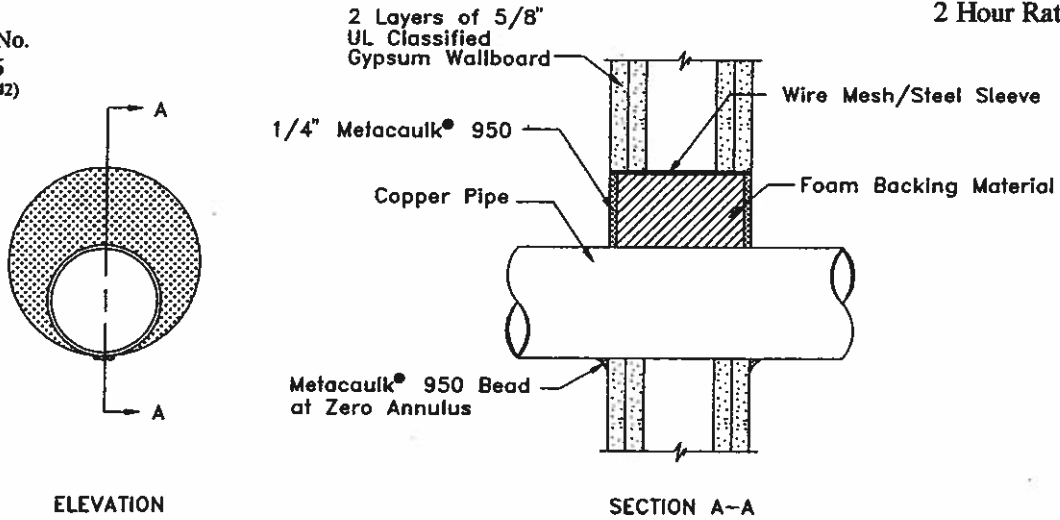

SYSTEM CONFIGURATION INFORMATION

METACAULK® PRODUCT(S)			PENETRATING ITEM(S)			HOLE SIZE		ANNULAR SPACING			ADDITIONAL INSTALLATION MATERIALS AND AIDS			BACKING MATERIAL		ASTM E 814 RATING	
FILL MAT'L	MIN. THICK.	OTHER	TYPE	SIZE	INSULATION	MAX.	MIN.	MAX.	WIRE MESH	STEEL SLEEVE	OTHER	TYPE	DEPTH	T	F		
950	1/4" both sides	none	copper pipe, Type L (or heavier)	up to 4" I.D.	none	10 1/8"	0"	3"	No. 8 steel wire cloth	minimum 20 gauge galvanized steel	none	foam backer rod	full wall	0	2		

INSTALLATION INSTRUCTIONS

These instructions are for the installation of through-penetration fire stop system 950GW-26 in minimum 5 inch thick steel or wood stud fire rated gypsum wallboard partitions as listed by Underwriters Laboratories Inc. Refer to above drawings and System Configuration Information for component details.

- | Step | Procedure |
|------|---|
| 1 | Cut hole in gypsum wallboard in required size to accommodate pipe penetration and allowable annular spacing. Do not exceed maximum specified hole diameter. |
| 2 | Install up to 4 inch I.D. copper pipe. Support pipe rigidly on both sides of wall. |
| 3 | Install specified wire mesh or galvanized steel sleeve cut to size, formed to hole shape, centered inside wall around pipe, and allowed to spring back snugly against periphery of hole such that it is recessed a minimum of 1/8 inch in from wall surface on both sides. |
| 4 | Clean all hole and pipe surfaces in penetration area to remove loose debris, dirt, oil, wax, grease, old caulking, etc. |
| 5 | Install backing material by firmly packing annular space with full wall depth of specified foam backer rod. Recess backing material at least 1/4 inch in from both sides of wall to accommodate the required fill depth of Metacaulk® 950. |
| 6 | Gun, trowel and/or pump Metacaulk® 950 firestopping sealant to a minimum 1/4 inch depth on both sides of wall. Trowel sealant surfaces flush with wall surfaces and to a smooth defect-free finish. Apply 1/2 inch diameter caulking bead along all zero annular contact areas on both sides of wall and tool smooth. |

JOB NAME:

ARCHITECT:

CUSTOMER:

CUSTOMER ORDER NO:

CONTRACTOR:

REPRESENTATIVE:

REPRESENTATIVE ORDER NO:

THE RECTORSEAL CORPORATION
2601 SPENWICK HOUSTON, TEXAS 77055

REVISION NUMBER:
SHEET NUMBER:

of AP-B-7

THIS PAGE INTENTIONALLY BLANK

SECTION 079200 - JOINT SEALANTS

1.1 RELATED DOCUMENTS

- A. Drawings and general provisions of the Contract, including General and Supplementary Conditions and Division 01 Specification Sections, apply to this Section.

1.2 SUMMARY

- A. This Section includes joint sealants for applications indicated on the Drawings or required by typical construction methods that are not specifically included under any other specifications section.

1.3 PERFORMANCE REQUIREMENTS

- A. Provide elastomeric joint sealants that establish and maintain watertight and airtight continuous joint seals without staining or deteriorating joint substrates.
- B. Provide joint sealants for interior applications that establish and maintain airtight and water-resistant continuous joint seals without staining or deteriorating joint substrates.

1.4 SUBMITTALS

- A. Product Data: For each joint-sealant product indicated.
- B. Samples for Selection: Manufacturer's color charts consisting of strips of cured sealants showing the full range of colors available for each product exposed to view.

1.5 QUALITY ASSURANCE

- A. Source Limitations: Obtain each type of joint sealant through one source from a single manufacturer.

1.6 PROJECT CONDITIONS

- A. Do not proceed with installation of joint sealants under the following conditions:
 - 1. When ambient and substrate temperature conditions are outside limits permitted by joint-sealant manufacturer or are below 40 deg F (5 deg C).
 - 2. When joint substrates are wet.
 - 3. Where joint widths are less than those allowed by joint-sealant manufacturer for applications indicated.
 - 4. Contaminants capable of interfering with adhesion have not yet been removed from joint substrates.

PART 2 - PRODUCTS

2.1 MANUFACTURERS

- A. Products: Subject to compliance with requirements, provide one of the products listed in other Part 2 articles.
- B. Products by other manufacturers are subject to Architect's approval prior to bidding.

2.2 MATERIALS, GENERAL

- A. Compatibility: Provide joint sealants, backings, and other related materials that are compatible with one another and with joint substrates under conditions of service and application, as demonstrated by sealant manufacturer, based on testing and field experience.
- B. Colors of Exposed Joint Sealants: As selected by Architect from manufacturer's full range.

2.3 ELASTOMERIC JOINT SEALANTS

- A. Elastomeric Sealants: Comply with ASTM C 920 and other requirements indicated for each liquid-applied chemically curing sealant specified, including those referencing ASTM C 920 classifications for type, grade, class, and uses related to exposure and joint substrates.
- B. Stain-Test-Response Characteristics: Where elastomeric sealants are specified to be nonstaining to porous substrates, provide products that have undergone testing according to ASTM C 1248 and have not stained porous joint substrates indicated for Project.
- C. Suitability for Immersion in Liquids. Where elastomeric sealants are indicated for Use I for joints that will be continuously immersed in liquids, provide products that have undergone testing according to ASTM C 1247 and qualify for the length of exposure indicated by reference to ASTM C 920 for Class 1 or 2. Liquid used for testing sealants is deionized water, unless otherwise indicated.
- D. Single-Component Neutral-Curing Silicone Sealant: Use this sealant for joints subject to movement at interior and exterior locations such as metals, glass, and ceramic type materials, and at exterior locations at stucco and concrete masonry exposed to sun and weather.
 - 1. Products:
 - a. Dow Corning Corporation; 790.
 - b. Tremco; Spectrem 1
 - c. GE Silicones; SilPruf SCS2000.
 - d. Pecora Corporation; 864.
- E. Single-Component Mildew-Resistant Acid-Curing Silicone Sealant: Use this sealant for joints in toilet rooms and interior wet areas.
 - 1. Products:

- a. Dow Corning Corporation; 786 Mildew Resistant.
- b. GE Silicones; Sanitary SCS1700.
- c. Tremco; Tremsil 200.

F. Single-Component Non-sag Urethane Sealant: Use this sealant for joints subject to movement at building exterior at concrete, masonry, and metals where not exposed to sun, including protected expansion / control joints in walls, and at certain interior locations where indicated.

1. Products:

- a. Sika Corporation, Inc.; Sikaflex - 1a.
- b. Sonneborn, Division of ChemRex Inc.; NP 1.
- c. Tremco; Vulkem 116.

2.4 SOLVENT-RELEASE JOINT SEALANTS

A. Butyl-Rubber-Based Solvent-Release Joint Sealant: Comply with ASTM C 1085. Use this sealant in connection with exterior sheet metal work.

1. Products:

- a. Bostik Findley; Bostik 300.
- b. Fuller, H. B. Company; SC-0296.
- c. Fuller, H. B. Company; SC-0288.
- d. Pecora Corporation; BC-158.
- e. Polymeric Systems Inc.; PSI-301
- f. Sonneborn, Division of ChemRex Inc.; Sonneborn Multi-Purpose Sealant.
- g. Tremco; Tremco Butyl Sealant.

2.5 LATEX JOINT SEALANTS

A. Latex Sealant: Comply with ASTM C 834, Type P, Grade NF. Use this sealant for general interior caulking and at drywall, plaster, concrete block, and other construction to be painted.

B. Products:

- 1. Pecora Corporation; AC-20+.
- 2. Sonneborn, Division of ChemRex Inc.; Sonolac.
- 3. Tremco; Tremflex 834.

2.6 ACOUSTICAL JOINT SEALANTS

A. Acoustical Sealant for Exposed and Concealed Joints: Manufacturer's standard nonsag, paintable, nonstaining latex sealant complying with ASTM C 834 and the following:

- 1. Product effectively reduces airborne sound transmission through perimeter joints and openings in building construction as demonstrated by testing representative assemblies according to ASTM E 90.

2. Products:

- a. Pecora Corporation; AC-20 FTR Acoustical and Insulation Sealant.
- b. United States Gypsum Co.; SHEETROCK Acoustical Sealant.

2.7 JOINT-SEALANT BACKING

- A. General: Provide sealant backings of material and type that are nonstaining; are compatible with joint substrates, sealants, primers, and other joint fillers; and are approved for applications indicated by sealant manufacturer based on field experience and laboratory testing.
- B. Cylindrical Sealant Backings: ASTM C 1330, Type C (closed-cell material with a surface skin), O (open-cell material), B (bicellular material with a surface skin) or any of the preceding types, as approved in writing by joint-sealant manufacturer for joint application indicated, and of size and density to control sealant depth and otherwise contribute to producing optimum sealant performance. Provide expandable backer rod where noted on Drawings or required for specific conditions.
- C. Bond-Breaker Tape: Polyethylene tape or other plastic tape recommended by sealant manufacturer for preventing sealant from adhering to rigid, inflexible joint-filler materials or joint surfaces at back of joint where such adhesion would result in sealant failure. Provide self-adhesive tape where applicable.

2.8 MISCELLANEOUS MATERIALS

- A. Primer: Material recommended by joint-sealant manufacturer where required for adhesion of sealant to joint substrates indicated, as determined from preconstruction joint-sealant-substrate tests and field tests.
- B. Cleaners for Nonporous Surfaces: Chemical cleaners acceptable to manufacturers of sealants and sealant backing materials, free of oily residues or other substances capable of staining or harming joint substrates and adjacent nonporous surfaces in any way, and formulated to promote optimum adhesion of sealants to joint substrates.
- C. Masking Tape: Nonstaining, nonabsorbent material compatible with joint sealants and surfaces adjacent to joints.

2.9 FLOOR SLAB JOINT SEALANT

- A. High Performance Urethane Sealant, ASTM C 920. Tremco Dymonic 100 or equivalent.

EXECUTION

2.10 EXAMINATION

- A. Examine joints indicated to receive joint sealants, with Installer present, for compliance with requirements for joint configuration, installation tolerances, and other conditions affecting joint-sealant performance.
- B. Proceed with installation only after unsatisfactory conditions have been corrected.

2.11 PREPARATION

- A. Surface Cleaning of Joints: Clean out joints immediately before installing joint sealants to comply with joint-sealant manufacturer's written instructions and the following requirements:
 - 1. Remove all foreign material from joint substrates that could interfere with adhesion of joint sealant, including dust, paints (except for permanent, protective coatings tested and approved for sealant adhesion and compatibility by sealant manufacturer), old joint sealants, oil, grease, waterproofing, water repellents, water, surface dirt, and frost.
 - 2. Clean porous joint substrate surfaces by brushing, grinding, blast cleaning, mechanical abrading, or a combination of these methods to produce a clean, sound substrate capable of developing optimum bond with joint sealants. Remove loose particles remaining after cleaning operations above by vacuuming or blowing out joints with oil-free compressed air.
 - 3. Remove laitance and form-release agents from concrete.
 - 4. Clean nonporous surfaces with chemical cleaners or other means that do not stain, harm substrates, or leave residues capable of interfering with adhesion of joint sealants.:
- B. Joint Priming: Prime joint substrates, where recommended in writing by joint-sealant manufacturer, based on preconstruction joint-sealant-substrate tests or prior experience. Apply primer to comply with joint-sealant manufacturer's written instructions. Confine primers to areas of joint-sealant bond; do not allow spillage or migration onto adjoining surfaces.
- C. Masking Tape: Use masking tape where required to prevent contact of sealant with adjoining surfaces that otherwise would be permanently stained or damaged by such contact or by cleaning methods required to remove sealant smears. Remove tape immediately after tooling without disturbing joint seal.

2.12 INSTALLATION OF JOINT SEALANTS

- A. General: Comply with joint-sealant manufacturer's written installation instructions for products and applications indicated, unless more stringent requirements apply.
- B. Sealant Installation Standard: Comply with recommendations in ASTM C 1193 for use of joint sealants as applicable to materials, applications, and conditions indicated.

- C. Acoustical Sealant Application Standard: Comply with recommendations in ASTM C 919 for use of joint sealants in acoustical applications as applicable to materials, applications, and conditions indicated.
- D. Install sealant backings of type indicated to support sealants during application and at position required to produce cross-sectional shapes and depths of installed sealants relative to joint widths that allow optimum sealant movement capability.
 - 1. Do not leave gaps between ends of sealant backings.
 - 2. Do not stretch, twist, puncture, or tear sealant backings.
 - 3. Remove absorbent sealant backings that have become wet before sealant application and replace them with dry materials.
- E. Install bond-breaker tape behind sealants where sealant backings are not used between sealants and backs of joints.
- F. Install sealants using proven techniques that comply with the following and at the same time backings are installed:
 - 1. Place sealants so they directly contact and fully wet joint substrates.
 - 2. Completely fill recesses in each joint configuration.
 - 3. Produce uniform, cross-sectional shapes and depths relative to joint widths that allow optimum sealant movement capability.
- G. Tooling of Nonsag Sealants: Immediately after sealant application and before skinning or curing begins, tool sealants according to requirements specified below to form smooth, uniform beads of configuration indicated; to eliminate air pockets; and to ensure contact and adhesion of sealant with sides of joint.
 - 1. Remove excess sealant from surfaces adjacent to joints.
 - 2. Use tooling agents that are approved in writing by sealant manufacturer and that do not discolor sealants or adjacent surfaces.
 - 3. Provide concave joint configuration per Figure 5A in ASTM C 1193, unless otherwise indicated.

2.13 CLEANING

- A. Clean off excess sealant or sealant smears adjacent to joints as the Work progresses by methods and with cleaning materials approved in writing by manufacturers of joint sealants and of products in which joints occur.

2.14 PROTECTION

- A. Protect joint sealants during and after curing period from contact with contaminating substances and from damage resulting from construction operations or other causes so sealants are without deterioration or damage at time of Substantial Completion. If, despite such protection, damage or deterioration occurs, cut out and remove damaged or deteriorated joint sealants immediately so installations with repaired areas are indistinguishable from original work.

END OF SECTION 079200

THIS PAGE INTENTIONALLY BLANK

SECTION 081113 - HOLLOW METAL DOORS AND FRAMES

PART 1 - GENERAL

1.1 RELATED DOCUMENTS

- A. Drawings and general provisions of the Contract, including General and Supplementary Conditions and Division 01 Specification Sections, apply to this Section.

1.2 SUMMARY

- A. Section Includes:
 - 1. Standard hollow metal doors.
 - 2. Standard hollow metal door, sidelite, and borrow lite frames.

1.3 DEFINITIONS

- A. Minimum Thickness: Minimum thickness of base metal without coatings.
- B. SDI Designations: Reference to Steel Door Institute (SDI).
- C. Standard Hollow Metal Work: Hollow metal work fabricated according to ANSI/SDI A250.8.

1.4 SUBMITTALS

- A. Product Data: For each type of product indicated. Include construction details, material descriptions, core descriptions, fire-resistance rating, and finishes.
- B. Shop Drawings: Include the following:
 - 1. Elevations of each door design.
 - 2. Details of doors, including vertical and horizontal edge details and metal thicknesses.
 - 3. Frame details for each frame type, including dimensioned profiles and metal thicknesses.
 - 4. Locations of reinforcement and preparations for hardware.
 - 5. Details of each different wall opening condition.
 - 6. Details of anchorages, joints, field splices, and connections.
 - 7. Details of accessories.
 - 8. Details of moldings, removable stops, and glazing.
 - 9. Details of conduit and preparations for power, signal, and control systems, if any.
- C. Other Action Submittals:
 - 1. Schedule: Provide a schedule of hollow metal work prepared by or under the supervision of supplier, using same reference numbers for details and openings as those on Drawings. Coordinate with door hardware schedule.

- D. Source Limitations: Obtain hollow metal work from single source from single manufacturer.
- E. Fire-Rated Door Assemblies: Assemblies complying with NFPA 80 that are listed and labeled by a qualified testing agency, for fire-protection ratings indicated.
 - 1. All fire rated doors and frames shall be tested and labeled in conformance to the requirements of Section 716 of the International Building Code, 2018 Edition.
- F. Provide doors and frames complying with Steel Door Institute “Recommended Specifications Standard Steel Doors and Frames”, ANSI/SDI-100, and doors and frames that meet or exceed Hollow Metal Manufacturers Association (HMMA) manufacturing tolerances and that meet or exceed HMMA installation tolerances.

1.5 DELIVERY, STORAGE, AND HANDLING

- A. Deliver hollow metal work palletized, wrapped, or crated to provide protection during transit and Project-site storage. Do not use non-vented plastic.
 - 1. Provide additional protection to prevent damage to finish of factory-finished units.
- B. Deliver welded frames with two removable spreader bars across bottom of frames, tack welded to jambs and mullions.
- C. Store hollow metal work under cover at Project site. Place in stacks of five units maximum in a vertical position with heads up, spaced by blocking, on minimum 4-inch- (102-mm-) high wood blocking. Do not store in a manner that traps excess humidity.
 - 1. Provide minimum 1/4-inch (6-mm) space between each stacked door to permit air circulation.

1.6 PROJECT CONDITIONS

- A. Field Measurements: Verify actual dimensions of openings by field measurements before fabrication.

1.7 COORDINATION

- A. Coordinate installation of anchorages for hollow metal frames. Furnish setting drawings, templates, and directions for installing anchorages, including sleeves, concrete inserts, anchor bolts, and items with integral anchors. Deliver such items to Project site in time for installation.
- B. Coordinate all specified exterior and interior doors that are shown on the Hardware Schedule to be designated for installation of future access control hardware and systems. The hollow metal doors at these locations shall be fabricated with an interior horizontal cable raceway for extension of wiring from hinge to latch for electronic access control wiring.

PART 2 - PRODUCTS

2.1 MANUFACTURERS

- A. Manufacturers: Subject to compliance with requirements, provide products by one of the following:
1. Amweld Building Products, LLC.
 2. Ceco Door Products; an Assa Abloy Group company.
 3. Curries Company; an Assa Abloy Group company.
 4. Fleming Door Products Ltd.; an Assa Abloy Group company.
 5. Kewanee Corporation (The).
 6. Mesker Door Inc.
 7. Steelcraft; an Ingersoll-Rand company.

2.2 MATERIALS

- A. Cold-Rolled Steel Sheet: ASTM A 1008/A 1008M, Commercial Steel (CS), Type B; suitable for exposed applications.
- B. Hot-Rolled Steel Sheet: ASTM A 1011/A 1011M, Commercial Steel (CS), Type B; free of scale, pitting, or surface defects; pickled and oiled.
- C. Metallic-Coated Steel Sheet: ASTM A 653/A 653M, Commercial Steel (CS), Type B; with minimum G60 (Z180) or A60 (ZF180) metallic coating.
- D. Frame Anchors: ASTM A 591/A 591M, Commercial Steel (CS), 40Z (12G) coating designation; mill phosphatized.
1. For anchors built into exterior walls, steel sheet complying with ASTM A 1008/A 1008M or ASTM A 1011/A 1011M, hot-dip galvanized according to ASTM A 153/A 153M, Class B.
- E. Inserts, Bolts, and Fasteners: Hot-dip galvanized according to ASTM A 153/A 153M.
- F. Powder-Actuated Fasteners in Concrete: Fastener system of type suitable for application indicated, fabricated from corrosion-resistant materials, with clips or other accessory devices for attaching hollow metal frames of type indicated.
- G. Grout: ASTM C 476, except with a maximum slump of 4 inches (102 mm), as measured according to ASTM C 143/C 143M.
- H. Mineral-Fiber Insulation: ASTM C 665, Type I (blankets without membrane facing); consisting of fibers manufactured from slag or rock wool with 6- to 12-lb/cu. ft. (96- to 192-kg/cu. m) density; with maximum flame-spread and smoke-development indexes of 25 and 50, respectively; passing ASTM E 136 for combustion characteristics.
- I. Glazing: Comply with requirements in Division 08 Section "Glazing."

- J. Bituminous Coating: Cold-applied asphalt mastic, SSPC-Paint 12, compounded for 15-mil (0.4-mm) dry film thickness per coat. Provide inert-type noncorrosive compound free of asbestos fibers, sulfur components, and other deleterious impurities.

2.3 STANDARD HOLLOW METAL DOORS

- A. General: Provide doors of design indicated, not less than thickness indicated; fabricated with smooth surfaces, without visible joints or seams on exposed faces unless otherwise indicated. Comply with ANSI/SDI A250.8.
 - 1. Design: Flush panel.
 - 2. Core Construction: Manufacturer's standard polystyrene, polyurethane, polyisocyanurate, or vertical steel-stiffener core.
 - a. Fire Door Core: As required to provide fire-protection and temperature-rise ratings indicated.
 - b. Thermal-Rated (Insulated) Doors: At building exterior and where indicated, provide doors fabricated with thermal-resistance value (R-value) of not less than 6.0 deg F x h x sq. ft./Btu (1.057 K x sq. m/W) when tested according to ASTM C 1363.
 - 1) Locations: Exterior doors.
 - 3. Vertical Edges for Single-Acting Doors: Manufacturer's standard.
 - a. Beveled Edge: 1/8 inch in 2 inches (3 mm in 50 mm).
 - 4. Top and Bottom Edges: Closed with flush or inverted 0.042-inch- (1.0-mm-) thick, end closures or channels of same material as face sheets.
 - 5. Tolerances: Comply with SDI 117, "Manufacturing Tolerances for Standard Steel Doors and Frames."
- B. Exterior Doors: Face sheets fabricated from metallic-coated steel sheet. Provide doors complying with requirements indicated below by referencing ANSI/SDI A250.8 for level and model and ANSI/SDI A250.4 for physical performance level:
 - 1. Level 4 and Physical Performance Level A (Maximum Duty), Model 1 (Full Flush), 0.067".
- C. Hardware Reinforcement: Fabricate according to ANSI/SDI A250.6 with reinforcing plates from same material as door face sheets.
- D. Fabricate concealed stiffeners and hardware reinforcement from either cold- or hot-rolled steel sheet.
- E. Openings in doors for lights and / or louvers shall be cut and perimeter reinforced at place of door manufacture. Do not field cut openings in doors.
- F. All specified exterior and interior doors that are shown on the Hardware Schedule to be designated for installation of future access control hardware and systems shall have the hollow

metal doors at these locations fabricated with an interior horizontal cable raceway for extension of wiring from hinge to latch for electronic access control wiring.

2.4 STANDARD HOLLOW METAL FRAMES

- A. General: Comply with ANSI/SDI A250.8 and with details indicated for type and profile.
- B. Exterior Frames: Fabricated from metallic-coated steel sheet.
 - 1. Fabricate frames with mitered or coped corners.
 - 2. Fabricate frames as full profile welded unless otherwise indicated.
 - 3. Frames for Level 4 Steel Doors: 0.053-inch- (1.3-mm-) thick steel sheet.
- C. Interior Frames: Fabricated from cold-rolled steel sheet.
 - 1. Fabricate frames with mitered or coped corners.
 - 2. Fabricate frames as face welded unless otherwise indicated.
 - 3. Frames for Wood Doors: 0.053-inch- (1.3-mm-) thick steel sheet.
 - 4. Frames for Borrow Lights: 0.053-inch- (1.3-mm-) thick steel sheet.
- D. Hardware Reinforcement: Fabricate according to ANSI/SDI A250.6 with reinforcement plates from same material as frames.

2.5 FRAME ANCHORS

- A. Jamb Anchors:
 - 1. Masonry Type: Adjustable strap-and-stirrup or T-shaped anchors to suit frame size, not less than 0.042 inch (1.0 mm) thick, with corrugated or perforated straps not less than 2 inches (50 mm) wide by 10 inches (250 mm) long; or wire anchors not less than 0.177 inch (4.5 mm) thick.
 - 2. Steel Stud-Wall Type: Designed to engage stud, welded to back of frames; not less than 0.042 inch (1.0 mm) thick.
 - 3. Postinstalled Expansion Type for In-Place Concrete or Masonry: Minimum 3/8-inch- (9.5-mm-) diameter bolts with expansion shields or inserts. Provide pipe spacer from frame to wall, with throat reinforcement plate, welded to frame at each anchor location. Use subject to approval of the Architect for specific conditions.
- B. Floor Anchors: Formed from same material as frames, not less than 0.042 inch (1.0 mm) thick, and as follows:
 - 1. Monolithic Concrete Slabs: Clip-type anchors, with two holes to receive fasteners.

2.6 STOPS AND MOLDINGS

- A. Moldings for Glazed Lites in Doors: Minimum 0.032 inch (0.8 mm) thick, fabricated from same material as door face sheet in which they are installed.
- B. Fixed Frame Moldings: Formed integral with hollow metal frames, a minimum of 5/8 inch (16 mm) high unless otherwise indicated.

- C. Loose Stops for Glazed Lites in Frames: Minimum 0.032 inch (0.8 mm) thick, fabricated from same material as frames in which they are installed.

2.7 LOUVERS

- A. Provide louvers for interior doors, where indicated, that comply with SDI 111C, with blades or baffles formed of 0.020-inch- ((0.5-mm-)) thick, cold-rolled steel sheet set into 0.032-inch- (0.8-mm-) thick steel frame.
 - 1. Sight proof Louver: Stationary louvers constructed with inverted V-shaped or Y-shaped blades.

2.8 ACCESSORIES

- A. Mullions and Transom Bars: Join to adjacent members by welding or rigid mechanical anchors.
- B. Grout Guards: Formed from same material as frames, not less than 0.016 inch (0.4 mm) thick.

2.9 FABRICATION

- A. Fabricate hollow metal work to be rigid and free of defects, warp, or buckle. Accurately form metal to required sizes and profiles, with minimum radius for thickness of metal. Where practical, fit and assemble units in manufacturer's plant. To ensure proper assembly at Project site, clearly identify work that cannot be permanently factory assembled before shipment.
- B. Tolerances: Fabricate hollow metal work to tolerances indicated in SDI 117.
- C. Hollow Metal Doors:
 - 1. Exterior Doors: Provide weep-hole openings in bottom of exterior doors to permit moisture to escape. Seal joints in top edges of doors against water penetration.
 - 2. Glazed Lites: Factory cut openings in doors.
 - 3. Electrical Raceways: Provide hollow metal doors to receive electrified hardware with concealed wiring harness and standardized Molex™ plug connectors on both ends to accommodate up to twelve wires. Coordinate connectors on end of the wiring harness to plug directly into the electrified hardware and the through-wire transfer hardware or wiring harness specified in hardware sets in Division 08 Sections "Door Hardware" and "Access Control Hardware". Wire nut connections are not acceptable.
- D. Hollow Metal Frames: Where frames are fabricated in sections due to shipping or handling limitations, provide alignment plates or angles at each joint, fabricated of same thickness metal as frames.
 - 1. Welded Frames: Weld joints continuously; grind, fill, dress, and make smooth, flush, and invisible.
 - 2. Sidelight and Borrow Lite Frames: Provide closed tubular members with no visible face seams or joints, fabricated from same material as door frame. Fasten members at crossings and to jambs by butt welding.

3. Provide countersunk, flat- or oval-head exposed screws and bolts for exposed fasteners unless otherwise indicated.
 4. Grout Guards: Weld guards to frame at back of hardware mortises in frames to be grouted.
 5. Floor Anchors: Weld anchors to bottom of jambs and mullions with at least four spot welds per anchor.
 6. Jamb Anchors: Provide number and spacing of anchors as follows:
 - a. Masonry Type: Locate anchors not more than 18 inches (457 mm) from top and bottom of frame. Space anchors not more than 32 inches (813 mm) o.c. and as follows:
 - 1) Two anchors per jamb up to 60 inches (1524 mm) high.
 - 2) Three anchors per jamb from 60 to 90 inches (1524 to 2286 mm) high.
 - 3) Four anchors per jamb from 90 to 120 inches (2286 to 3048 mm) high.
 - b. Stud-Wall Type: Locate anchors not more than 18 inches (457 mm) from top and bottom of frame. Space anchors not more than 32 inches (813 mm) o.c. and as follows:
 - 1) Three anchors per jamb up to 60 inches (1524 mm) high.
 - 2) Four anchors per jamb from 60 to 90 inches (1524 to 2286 mm) high.
 - 3) Five anchors per jamb from 90 to 96 inches (2286 to 2438 mm) high.
 - c. Post installed Expansion Type: Locate anchors not more than 6 inches (152 mm) from top and bottom of frame. Space anchors not more than 26 inches (660 mm) o.c.
 7. Door Silencers: Except on weather-stripped or gasketed doors, drill stops to receive door silencers as follows. Keep holes clear during construction.
 - a. Single-Door Frames: Drill stop in strike jamb to receive three door silencers.
 - b. Double-Door Frames: Drill stop in head jamb to receive two door silencers.
- E. Fabricate concealed stiffeners, edge channels, and hardware reinforcement from either cold- or hot-rolled steel sheet.
- F. Hardware Preparation: Factory prepare hollow metal work to receive templated mortised hardware; include cutouts, reinforcement, mortising, drilling, and tapping according to the Door Hardware Schedule and templates furnished as specified in Division 08 Section "Door Hardware."
1. Locate hardware as indicated, or if not indicated, according to ANSI/SDI A250.8.
 2. Reinforce doors and frames to receive non-templated, mortised and surface-mounted door hardware.
 3. Comply with applicable requirements in ANSI/SDI A250.6 and ANSI/DHI A115 Series specifications for preparation of hollow metal work for hardware.
 4. Coordinate locations of conduit and wiring boxes for electrical connections, if any, with Division 26 Sections.
 5. Electrical Knock Out Boxes: Factory weld 18-gauge electrical knock out boxes to frame for electrical hardware preps; including but not limited to, electric through wire transfer

hardware, electrical raceways and wiring harnesses, door position switches, electric strikes, magnetic locks, and jamb mounted card readers as specified in hardware sets in Division 08 Sections "Door Hardware" and "Access Control Hardware".

- a. Provide electrical knock out boxes with a dual 1/2-inch and 3/4-inch knockouts.
- b. Conduit to be coordinated and installed in the field (Division 26) from middle hinge box and strike box to door position box.
- c. Electrical knock out boxes to comply with NFPA requirements and fit electrical door hardware as specified in hardware sets in Division 08 Section "Door Hardware".
- d. Electrical knock out boxes for continuous hinges should be located in the center of the vertical dimension on the hinge jamb.

G. Stops and Moldings: Provide stops and moldings around glazed lites where indicated. Form corners of stops and moldings with butted or mitered hairline joints.

1. Single Glazed Lites: Provide fixed stops and moldings welded on secure side of hollow metal work.
2. Multiple Glazed Lites: Provide fixed and removable stops and moldings so that each glazed lite is capable of being removed independently.
3. Provide fixed frame moldings on outside of exterior and on secure side of interior doors and frames.
4. Provide loose stops and moldings on inside of hollow metal work.
5. Coordinate rabbet width between fixed and removable stops with type of glazing and type of installation indicated.

2.10 STEEL FINISHES

A. Prime Finish: Apply manufacturer's standard primer immediately after cleaning and pretreating.

1. Shop Primer: Manufacturer's standard, fast-curing, lead- and chromate-free primer complying with ANSI/SDI A250.10 acceptance criteria; recommended by primer manufacturer for substrate; compatible with substrate and field-applied coatings despite prolonged exposure.

PART 3 - EXECUTION

3.1 EXAMINATION

- A. Examine substrates, areas, and conditions, with Installer present, for compliance with requirements for installation tolerances and other conditions affecting performance of the Work.
- B. Examine roughing-in for embedded and built-in anchors to verify actual locations before frame installation.
- C. For the record, prepare written report, endorsed by Installer, listing conditions detrimental to performance of the Work.
- D. Proceed with installation only after unsatisfactory conditions have been corrected.

3.2 PREPARATION

- A. Remove welded-in shipping spreaders installed at factory. Restore exposed finish by grinding, filling, and dressing, as required to make repaired area smooth, flush, and invisible on exposed faces.
- B. Prior to installation, adjust and securely brace welded hollow metal frames for squareness, alignment, twist, and plumbness to the following tolerances:
 - 1. Squareness: Plus or minus 1/16 inch (1.6 mm), measured at door rabbet on a line 90 degrees from jamb perpendicular to frame head.
 - 2. Alignment: Plus or minus 1/16 inch (1.6 mm), measured at jambs on a horizontal line parallel to plane of wall.
 - 3. Twist: Plus or minus 1/16 inch (1.6 mm), measured at opposite face corners of jambs on parallel lines, and perpendicular to plane of wall.
 - 4. Plumbness: Plus or minus 1/16 inch (1.6 mm), measured at jambs on a perpendicular line from head to floor.
- C. Drill and tap doors and frames to receive nontemplated, mortised, and surface-mounted door hardware.

3.3 INSTALLATION

- A. General: Install hollow metal work plumb, rigid, properly aligned, and securely fastened in place; comply with Drawings and manufacturer's written instructions.
- B. Hollow Metal Frames: Install hollow metal frames of size and profile indicated. Comply with ANSI/SDI A250.11.
 - 1. Set frames accurately in position, plumbed, aligned, and braced securely until permanent anchors are set. After wall construction is complete, remove temporary braces, leaving surfaces smooth and undamaged.
 - a. At fire-protection-rated openings, install frames according to National Fire Protection Association (NFPA) NFPA 80.
 - b. Where frames are fabricated in sections because of shipping or handling limitations, field splice at approved locations by welding face joint continuously; grind, fill, dress, and make splice smooth, flush, and invisible on exposed faces.
 - c. Install frames with removable glazing stops located on secure side of opening.
 - d. Install door silencers in frames before grouting.
 - e. Remove temporary braces necessary for installation only after frames have been properly set and secured.
 - f. Check plumbness, squareness, and twist of frames as walls are constructed. Shim as necessary to comply with installation tolerances.
 - g. Field apply bituminous coating to backs of frames that are filled with grout.
 - 2. Floor Anchors: Provide floor anchors for each jamb and mullion that extends to floor, and secure with postinstalled expansion anchors.
 - a. Floor anchors may be set with powder-actuated fasteners instead of postinstalled expansion anchors if so indicated and approved on Shop Drawings.

3. Metal-Stud Partitions: Solidly pack mineral-fiber insulation behind frames.
 4. Masonry Walls: Coordinate installation of frames to allow for solidly filling space between frames and masonry with grout.
 5. Concrete Walls: Solidly fill space between frames and concrete with grout. Take precautions, including bracing frames, to ensure that frames are not deformed or damaged by grout forces.
 6. In-Place Concrete or Masonry Construction: Secure frames in place with postinstalled expansion anchors. Countersink anchors, and fill and make smooth, flush, and invisible on exposed faces.
 7. In-Place Gypsum Board Partitions: Secure frames in place with post installed expansion anchors through floor anchors at each jamb. Countersink anchors, and fill and make smooth, flush, and invisible on exposed faces.
 8. Installation Tolerances: Adjust hollow metal door frames for squareness, alignment, twist, and plumb to the following tolerances:
 - a. Squareness: Plus or minus 1/16 inch (1.6 mm), measured at door rabbet on a line 90 degrees from jamb perpendicular to frame head.
 - b. Alignment: Plus or minus 1/16 inch (1.6 mm), measured at jambs on a horizontal line parallel to plane of wall.
 - c. Twist: Plus or minus 1/16 inch (1.6 mm), measured at opposite face corners of jambs on parallel lines, and perpendicular to plane of wall.
 - d. Plumbness: Plus or minus 1/16 inch (1.6 mm), measured at jambs at floor.
- C. Hollow Metal Doors: Fit hollow metal doors accurately in frames, within clearances specified below. Shim as necessary. At existing hollow metal frames to receive new doors, field verify existing dimensions and conditions.
1. Non-Fire-Rated Standard Steel Doors:
 - a. Jambs and Head: 1/8 inch (3 mm) plus or minus 1/16 inch (1.6 mm).
 - b. Between Edges of Pairs of Doors: 1/8 inch (3 mm) plus or minus 1/16 inch (1.6 mm).
 - c. Between Bottom of Door and Top of Threshold: Maximum 3/8 inch (9.5 mm).
 - d. Between Bottom of Door and Top of Finish Floor (No Threshold): Maximum 3/4 inch (19 mm).
 2. Fire-Rated Doors: Install doors with clearances according to NFPA 80.
- D. Glazing: Secure stops with countersunk flat- or oval-head machine screws spaced uniformly not more than 9 inches (230 mm) o.c. and not more than 2 inches (50 mm) o.c. from each corner.

3.4 ADJUSTING AND CLEANING

- A. Final Adjustments: Check and readjust operating hardware items immediately before final inspection. Leave work in complete and proper operating condition. Remove and replace defective work, including hollow metal work that is warped, bowed, or otherwise unacceptable.
- B. Remove grout and other bonding material from hollow metal work immediately after installation.

- C. Prime-Coat Touchup: Immediately after erection, sand smooth rusted or damaged areas of prime coat and apply touchup of compatible air-drying, rust-inhibitive primer.
- D. Metallic-Coated Surfaces: Clean abraded areas and repair with galvanizing repair paint according to manufacturer's written instructions.

END OF SECTION 081113

THIS PAGE INTENTIONALLY BLANK

SECTION 081416 - FLUSH WOOD DOORS

PART 1 - GENERAL

1.1 RELATED DOCUMENTS

- A. Drawings and general provisions of the Contract, including General and Supplementary Conditions and Division 01 Specification Sections, apply to this Section.

1.2 SUMMARY

- A. Section Includes:
 - 1. Solid-core doors with wood-veneer faces.
 - a. All solid core doors shall have a factory drilled wire raceway from hinge to latch for future electrified hardware.
 - 2. Factory finishing flush wood doors.

1.3 SUBMITTALS

- A. Product Data: For each type of door indicated. Include details of core and edge construction, louvers, and trim for openings. Include factory-finishing specifications.
- B. Shop Drawings: Indicate location, size, and hand of each door; elevation of each kind of door; construction details not covered in Product Data; location and extent of hardware blocking; and other pertinent data.
- C. Samples for Selection: For factory-finished doors.
- D. Warranty: Sample of special warranty.

1.4 QUALITY ASSURANCE

- A. Source Limitations: Obtain flush wood doors from single manufacturer.
- B. Quality Standard: In addition to requirements specified, comply with WDMA I.S.1-A, "Architectural Wood Flush Doors."
- C. All fire rated doors and frames shall comply with NFPA Standard No. 80 and shall be tested and labeled in conformance to the requirements of Section 716 of the International Building Code, 2018 Edition. Installation shall comply with NFPA 80.

1.5 DELIVERY, STORAGE, AND HANDLING

- A. Comply with requirements of referenced standard and manufacturer's written instructions.
- B. Package doors individually in cardboard cartons.
- C. Mark each door on bottom rail with opening number used on Shop Drawings.

1.6 PROJECT CONDITIONS

- A. Environmental Limitations: Do not deliver or install doors until spaces are enclosed and weathertight, wet work in spaces is complete and dry, and HVAC system is operating and maintaining ambient temperature and humidity conditions at occupancy levels during the remainder of the construction period.
- B. Field verify dimensions and conditions associated with existing door frames to remain prior to ordering and fabricating doors for installation in existing frames.

1.7 WARRANTY

- A. Special Warranty: Manufacturer's standard form in which manufacturer agrees to repair or replace doors that fail in materials or workmanship within specified warranty period.
 - 1. Failures include, but are not limited to, the following:
 - a. Warping (bow, cup, or twist) more than 1/4 inch (6.4 mm) in a 42-by-84-inch (1067-by-2134-mm) section.
 - b. Telegraphing of core construction in face veneers exceeding 0.01 inch in a 3-inch (0.25 mm in a 76.2-mm) span.
 - 2. Warranty shall also include installation and finishing that may be required due to repair or replacement of defective doors.
 - 3. Warranty Period for Solid-Core Interior Doors: Life of installation.

PART 2 - PRODUCTS

2.1 MANUFACTURERS

- A. Manufacturers: Subject to compliance with requirements, provide products by the following:
 - 1. Oshkosh.
 - 2. Masonite.
 - 3. VT Industries.
- B. Doors by other manufacturers are subject to approval by the Architect.

2.2 DOOR CONSTRUCTION, GENERAL

- A. Low-Emitting Materials: Provide doors made with adhesives and composite wood products that do not contain urea formaldehyde.
- B. Window & Door Manufacturers Association (WDMA) WDMA I.S.1-A Performance Grade: Extra Heavy Duty
- C. Particleboard-Core Doors:
 - 1. Particleboard: ANSI A208.1, Grade LD-1 or Grade LD-2, made with binder containing no urea-formaldehyde resin.
 - 2. Blocking: Provide wood blocking in particleboard-core doors as follows:
 - a. 5-inch (125-mm) top-rail blocking, in doors indicated to have closers.
 - b. 5-inch (125-mm) bottom-rail blocking, in exterior doors and doors indicated to have kick, mop, or armor plates.
 - c. 5-inch (125-mm) mid-rail blocking, in doors indicated to have exit devices.

2.3 VENEERED-FACED DOORS FOR TRANSPARENT FINISH

- A. Interior Solid-Core Doors:
 - 1. Grade: Premium, with Grade A faces.
 - 2. Species: White Birch. No heartwood showing, 1/50 inch minimum thickness.
 - 3. Cut: Plain Sliced Select.
 - 4. Grain: Vertical.
 - 5. Assembly of Veneer Leaves on Door Faces: Balance match.
 - 6. Pair and Set Match: Provide for doors hung in same opening or separated only by mullions.
 - 7. Room Match: Provide door faces of compatible color and grain within each separate room or area of building.
 - 8. Exposed Vertical Edges: Same species as faces or a compatible species.
 - 9. Core: Particleboard.
 - 10. Construction: Five or seven plies. Stiles and rails are bonded to core, then entire unit abrasive planed before veneering. Faces are bonded to core using a hot press.
 - 11. WDMA I.S.1-A Performance Grade: Extra Heavy Duty

2.4 LOUVERS AND LIGHT FRAMES

- A. Metal Frames for Light Openings in Doors: Manufacturer's standard frame formed of 0.048-inch- (1.2-mm-) thick, cold-rolled steel sheet; pre-finished. Color as selected by Architect from manufacturer's full range
 - 1. Activar Air Louvers VLFEZ beveled vision lite or approved.

2.5 FABRICATION

- A. Factory fit doors to suit frame-opening sizes indicated. Comply with clearance requirements of referenced quality standard for fitting unless otherwise indicated.
- B. Factory machine doors for hardware that is not surface applied. Locate hardware to comply with Door Hardware Institute (DHI) DHI-WDHS-3. Comply with final hardware schedules, door frame Shop Drawings, DHI A115-W series standards, and hardware templates.
 - 1. Coordinate with hardware mortises in metal frames to verify dimensions and alignment before factory machining.
- C. Openings: Cut and trim openings through doors in factory.
 - 1. Light Openings: Trim openings with moldings of material and profile indicated.
 - 2. Glazing: Factory install glazing in doors indicated to be factory finished. Comply with applicable requirements in Division 08 Section "Glazing."
- D. Factory Drilled Wire Raceway: At all locations provide solid core wood doors with factory drilled wire raceway that extends from the hinge to the strike for routing of future access control wiring for electrified hardware installation.

2.6 FACTORY FINISHING

- A. General: Comply with referenced quality standard for factory finishing. Complete fabrication, including fitting doors for openings and machining for hardware that is not surface applied, before finishing.
 - 1. Finish faces, all four edges, edges of cutouts, and mortises. Stains and fillers may be omitted on bottom edges, edges of cutouts, and mortises.
- B. Finish doors at factory.
- C. Transparent Finish:
 - 1. Grade: Premium.
 - 2. Finish: WDMA TR-4 conversion varnish or TR-6 catalyzed polyurethane.
 - 3. Staining: As selected by Architect from manufacturer's full range of colors.
 - 4. Effect: Filled finish.
 - 5. Sheen: Semigloss.

PART 3 - EXECUTION

3.1 EXAMINATION

- A. Examine doors and installed door frames before hanging doors.
 - 1. Verify that frames comply with indicated requirements for type, size, location, and swing characteristics and have been installed with level heads and plumb jambs.

2. Reject doors with defects.
- B. Proceed with installation only after unsatisfactory conditions have been corrected.

3.2 INSTALLATION

- A. Hardware: For installation, see Division 08 Section "Door Hardware."
- B. Installation Instructions: Install doors to comply with manufacturer's written instructions and the referenced quality standard, and as indicated.
1. Install fire-rated doors, if any, in corresponding fire-rated frames according to NFPA 80.
- C. Job-Fitted Doors: Align and fit doors in frames with uniform clearances and bevels as indicated below; do not trim stiles and rails in excess of limits set by manufacturer or permitted for fire-rated doors. Machine doors for hardware. Seal edges of doors, edges of cutouts, and mortises after fitting and machining.
1. Clearances: Provide 1/8 inch (3.2 mm) at heads, jambs, and between pairs of doors. Provide 1/8 inch (3.2 mm) from bottom of door to top of decorative floor finish or covering unless otherwise indicated. Where threshold is shown or scheduled, provide 1/4 inch (6.4 mm) from bottom of door to top of threshold unless otherwise indicated.
 - a. Comply with NFPA 80 for fire-rated doors.
 2. Bevel non-fire-rated doors 1/8 inch in 2 inches (3-1/2 degrees) at lock and hinge edges.
 3. Bevel fire-rated doors 1/8 inch in 2 inches (3-1/2 degrees) at lock edge; trim stiles and rails only to extent permitted by labeling agency.
- D. Factory-Finished Doors: Restore finish before installation if fitting or machining is required at Project site.

3.3 ADJUSTING

- A. Operation: Rehang or replace doors that do not swing or operate freely.
- B. Finished Doors: Replace doors that are damaged or that do not comply with requirements. Doors may be repaired or refinished if work complies with requirements and shows no evidence of repair or refinishing.

END OF SECTION 081416

THIS PAGE INTENTIONALLY BLANK

SECTION 083113 - ACCESS DOORS AND FRAMES

PART 1 - GENERAL

1.1 RELATED DOCUMENTS

- A. Drawings and general provisions of the Contract, including General and Supplementary Conditions and Division 01 Specification Sections, apply to this Section.

1.2 SUMMARY

- A. This Section includes the following:
 - 1. Access doors and frames for floors, walls, and ceilings.

1.3 SUBMITTALS

- A. Product Data: For each type of access door and frame indicated. Include construction details, materials, individual components and profiles, and finishes.
- B. Shop Drawings: Show fabrication and installation details of access doors and frames for each type of substrate. Include plans, elevations, sections, details, and attachments to other work.
- C. Access Door and Frame Schedule: Provide complete access door and frame schedule, including types, locations, sizes, latching or locking provisions, and other data pertinent to installation.

1.4 QUALITY ASSURANCE

- A. Source Limitations: Obtain each type of access door and frame through one source from a single manufacturer.
- B. Size Variations: Obtain Architect's acceptance of manufacturer's standard-size units, which may vary slightly from sizes indicated.

PART 2 - PRODUCTS

2.1 STEEL MATERIALS

- A. Steel Plates, Shapes, and Bars: ASTM A 36/A 36M.
- B. Steel Sheet: Uncoated or electrolytic zinc-coated, ASTM A 591/A 591M with cold-rolled steel sheet substrate complying with ASTM A 1008/A 1008M, Commercial Steel (CS), exposed.

- C. Steel Finishes: Comply with National Association of Architectural Metal Manufacturer's (NAAMM) "Metal Finishes Manual for Architectural and Metal Products" for recommendations for applying and designating finishes.

- 1. Surface Preparation for Steel Sheet: Clean surfaces to comply with SSPC-SP 1, "Solvent Cleaning," to remove dirt, oil, grease, or other contaminants that could impair paint bond. Remove mill scale and rust, if present, from uncoated steel, complying with SSPC-SP 5/NACE No. 1, "White Metal Blast Cleaning," or SSPC-SP 8, "Pickling."
- 2. Factory-Primed Finish: Apply shop primer immediately after cleaning and pretreating.

2.2 STAINLESS-STEEL MATERIALS

- A. Rolled-Stainless-Steel Floor Plate: ASTM A 793, manufacturer's standard finish.
- B. Stainless-Steel Sheet, Strip, Plate, and Flat Bars: ASTM A 666, Type 304. Remove tool and die marks and stretch lines or blend into finish.
 - 1. Finish: Manufacturer's standard.

2.3 ALUMINUM MATERIALS

- A. Aluminum Extrusions: ASTM B 221 (ASTM B 221M), Alloy 6063-T6.
 - 1. Mill finish, Aluminum Association (AA) AA-M10 (Mechanical Finish: as fabricated, unspecified).
- B. Aluminum-Alloy Rolled Tread Plate: ASTM B 632/B 632M, Alloy 6061-T6.
 - 1. Mill finish, AA-M10 (Mechanical Finish: as fabricated, unspecified).
- C. Aluminum Sheet: ASTM B 209 (ASTM B 209M), alloy and temper recommended by aluminum producer and finisher for type of use and finish indicated, and with not less than strength and durability properties of Alloy 5005-H15; with minimum sheet thickness indicated representing specified thickness according to ANSI H35.2 (ANSI H35.2(M)).
 - 1. Mill Finish: AA-M10 (Mechanical Finish: as fabricated, unspecified).

2.4 ACCESS DOORS AND FRAMES FOR WALLS AND CEILINGS

- A. Manufacturers: Subject to compliance with requirements, provide products by one of the following:
 - 1. Babcock-Davis; A Cierra Products Co.
 - 2. Dur-Red Products.
 - 3. Karp Associates, Inc.
 - 4. Milcor Inc.
 - 5. Nystrom, Inc.
 - 6. Mifab Manufacturing

- B. Products by other manufacturers are subject to Architect's approval prior to bidding.
- C. Flush Access Doors and Frames with Exposed Trim: Fabricated from steel sheet.
 - 1. Locations: Wall and ceiling surfaces as required. Contractors shall provide access doors as needed to provide required or necessary access to equipment, systems, and / or components that require service or inspection.
 - 2. Door: Minimum 0.060-inch- (1.5-mm-) thick sheet metal, set flush with exposed face flange of frame.
 - 3. Frame: Minimum 0.060-inch- (1.5-mm-) thick sheet metal with 1-inch- (25-mm-) wide, surface-mounted trim.
 - 4. Hinges: Continuous piano.
 - 5. Latch: Cam latch operated by spanner head wrench with interior release.
 - 6. Lock: Cylinder.
 - a. Lock Preparation: Prepare door panel to accept the Owner's standard full sized interchangeable core and cylinder specified in Division 08 Section "Door Hardware."
 - 7. Wall and Ceiling Size: 24" x 24".
 - 8. Floor Location: Nystrom Floor Door 300 PSF, Model FDEP, or equivalent. 30 inch by 36 inch single door, steel construction.

2.5 FABRICATION

- A. General: Provide access door and frame assemblies manufactured as integral units ready for installation.
- B. Metal Surfaces: For metal surfaces exposed to view in the completed Work, provide materials with smooth, flat surfaces without blemishes. Do not use materials with exposed pitting, seam marks, roller marks, rolled trade names, or roughness.
- C. Doors and Frames: Grind exposed welds smooth and flush with adjacent surfaces. Furnish attachment devices and fasteners of type required to secure access panels to types of supports indicated.
- D. Latching Mechanisms: Furnish number required to hold doors in flush, smooth plane when closed.
 - 1. For cylinder lock, furnish two keys per lock and key all locks alike.

PART 3 - EXECUTION

3.1 INSTALLATION

- A. Comply with manufacturer's written instructions for installing access doors and frames.

- B. Set frames accurately in position and attach securely to supports with plane of face panels aligned with adjacent finish surfaces.

3.2 ADJUSTING AND CLEANING

- A. Adjust doors and hardware after installation for proper operation.
- B. Remove and replace doors and frames that are warped, bowed, or otherwise damaged.

END OF SECTION 083113

SECTION 083323 - OVERHEAD COILING DOORS

PART 1 - GENERAL

1.1 RELATED DOCUMENTS

- A. Drawings and general provisions of the Contract, including General and Supplementary Conditions and Division 01 Specification Sections, apply to this Section.

1.2 SUMMARY

- A. Section Includes:
 - 1. Counter doors.
 - a. Push up counter doors.
 - b. Motor operated counter doors.
- B. Refer to the Drawings for types, locations, and sizes of counter doors.

1.3 PERFORMANCE REQUIREMENTS

- A. Seismic Performance: Overhead coiling doors shall withstand the effects of earthquake motions determined according to SEI/ASCE 7.
 - 1. The term "withstand" means "the unit will remain in place without separation of any parts from the device when subjected to the seismic forces specified.
 - 2. Seismic Component Importance Factor: 1.5.
- B. Operation Cycles: Provide overhead coiling door components and operators capable of operating for not less than number of cycles indicated for each door. One operation cycle is complete when a door is opened from the closed position to the fully open position and returned to the closed position.

1.4 SUBMITTALS

- A. Product Data: For each type and size of overhead coiling door and accessory. Include the following:
 - 1. Construction details, material descriptions, dimensions of individual components, profiles for slats, and finishes.
 - 2. Rated capacities, operating characteristics, electrical characteristics, and furnished accessories.

- B. Shop Drawings: For each installation and for special components not dimensioned or detailed in manufacturer's product data. Include plans, elevations, sections, details, and attachments to other work.
 - 1. Detail equipment assemblies and indicate dimensions, weights, loads, required clearances, method of field assembly, components, and location and size of each field connection.
 - 2. Wiring Diagrams: For power, signal, and control wiring.
- C. Qualification Data: For qualified Installer.
- D. Maintenance Data: For overhead coiling doors to include in maintenance manuals.

1.5 QUALITY ASSURANCE

- A. Installer Qualifications: Manufacturer's authorized representative who is trained and approved for both installation and maintenance of units required for this Project.
- B. Source Limitations: Obtain overhead coiling doors from single source from single manufacturer.
 - 1. Obtain operators and controls from overhead coiling door manufacturer.
- C. Electrical Components, Devices, and Accessories: Listed and labeled as defined in National Fire Protection Association (NFPA) NFPA 70, by a qualified testing agency, and marked for intended location and application.

PART 2 - PRODUCTS

2.1 DOOR CURTAIN MATERIALS AND CONSTRUCTION

- A. Door Curtains: Fabricate overhead coiling-door curtain of interlocking metal slats, designed to withstand wind loading indicated, in a continuous length for width of door without splices. Unless otherwise indicated, provide slats of thickness and mechanical properties recommended by door manufacturer for performance, size, and type of door indicated, and as follows:
 - 1. Stainless-Steel Door Curtain Slats: ASTM A 666, Type 304; sheet thickness of 0.025 inch (22 gauge) and as required to meet requirements.
 - 2. ScreenGard perforated as noted for specific doors.
- B. Endlocks for Counter Doors: Manufacturer's standard locks on not less than alternate curtain slats for curtain alignment and resistance against lateral movement.
- C. Bottom Bar for Counter Doors: Manufacturer's standard continuous channel or tubular shape, fabricated from manufacturer's standard hot-dip galvanized steel, stainless steel, or aluminum extrusions to match curtain slats and finish.
- D. Curtain Jamb Guides: Manufacturer's standard angles or channels and angles of same material and finish as curtain slats with sufficient depth and strength to retain curtain, to allow curtain to

operate smoothly, and to withstand loading. Slot bolt holes for guide adjustment. Provide removable stops on guides to prevent overtravel of curtain.

2.2 HOOD

- A. General: Form sheet metal hood to entirely enclose coiled curtain and operating mechanism at opening head. Contour to fit end brackets to which hood is attached. Roll and reinforce top and bottom edges for stiffness. Form closed ends for surface-mounted hoods and fascia for any portion of between-jamb mounting that projects beyond wall face. Equip hood with intermediate support brackets as required to prevent sagging.

1. Stainless Steel: 0.025-inch- (0.64-mm-) thick stainless-steel sheet, Type 304, complying with ASTM A 666.

2.3 LOCKING DEVICES

- A. Slide Bolt: Fabricate with side-locking bolts to engage through slots in tracks located on both left and right jamb sides, operable from coil side.
- B. Safety Interlock Switch: Equip power-operated doors with safety interlock switch to disengage power supply when door is locked.

2.4 COUNTERBALANCING MECHANISM

- A. General: Counterbalance doors by means of manufacturer's standard mechanism with an adjustable-tension, steel helical torsion spring mounted around a steel shaft and contained in a spring barrel connected to top of curtain with barrel rings. Use grease-sealed bearings or self-lubricating graphite bearings for rotating members.

2.5 MANUAL DOOR OPERATORS

- A. Push-up Door Operation: Design counterbalance mechanism so required lift or pull for door operation does not exceed 30 lbf.

2.6 ELECTRIC DOOR OPERATORS

- A. General: Electric door operator assembly of size and capacity recommended and provided by door manufacturer for door and operation-cycles requirement specified, with electric motor and factory-prewired motor controls, starter, gear-reduction unit, solenoid-operated brake, clutch, remote-control stations, control devices, integral gearing for locking door, and accessories required for proper operation.
 1. Comply with NFPA 70.
 2. Provide control equipment complying with National Electric Manufacturer's Association (NEMA) NEMA ICS 1, NEMA ICS 2, and NEMA ICS 6, with NFPA 70 Class 2 control circuit, maximum 24 V, ac or dc.

- B. Usage Classification: Electric operator and components capable of operating for not less than number of cycles per hour indicated for each door.
- C. Door Operator Location(s): Operator location indicated for each door.
 - 1. Front-of-Hood Mounted: Operator is mounted to the right or left door head plate with the operator on coil side of the door-hood assembly and connected to the door drive shaft with drive chain and sprockets. Front clearance is required for this type of mounting.
- D. Electric Motors: Comply with the following:
 - 1. Electrical Characteristics:
 - a. Phase: Single phase.
 - b. Volts: 115.
 - c. Hertz: 60.
 - 2. Motor Type and Controller: Reversible motor and controller (disconnect switch) for motor exposure indicated.
 - 3. Motor Size: Manufacturer's Standard.
 - 4. Operating Controls, Controllers (Disconnect Switches), Wiring Devices, and Wiring: Manufacturer's standard unless otherwise indicated.
 - 5. Coordinate wiring requirements and electrical characteristics of motors and other electrical devices with building electrical system and each location where installed.
- E. Limit Switches: Equip each motorized door with adjustable switches interlocked with motor controls and set to automatically stop door at fully opened and fully closed positions.
- F. Obstruction Detection Device: Equip motorized door with indicated external automatic safety sensor capable of protecting full width of door opening
 - 1. Photoelectric Sensor: Manufacturer's standard system designed to detect an obstruction in door opening without contact between door and obstruction.
 - 2. Sensor Edge: Automatic safety sensor edge, located within astragal or weather stripping mounted to bottom bar. Contact with sensor activates device. Connect to control circuit using manufacturer's standard take-up reel or self-coiling cable.
- G. Remote-Control Station: Momentary-contact, three-button control station with push-button controls labeled "Open," "Close," and "Stop."
 - 1. Interior units, full-guarded, surface-mounted, heavy-duty type, with general-purpose NEMA ICS 6, Type 1 enclosure.
- H. Emergency Manual Operation: Equip each electrically powered door with capability for emergency manual operation. Design manual mechanism so required force for door operation does not exceed 30 lbf (133 N).

2.7 DOOR ASSEMBLY

- A. Counter Doors: Overhead coiling doors formed with curtain of interlocking metal slats.

1. Manufacturers / Products: Subject to compliance with requirements, provide the following:
 - a. Push-up operated counter doors, (CCD-2).
 - 1) Cookson Company / Type ESC 10 rolling counter door, face of wall mounted. Located at New Dish Room 155, with SceenGard perforated slats.
 - b. Motor-operated counter doors, (CCD-1).
 - 1) Cookson Company / Type ESC 10, jamb mounted with ELR electric sensing edge. Located at New Kitchen 152, with ScreenGard perforated slats.
 2. Products by other manufacturers are subject to Architect's approval prior to bidding.
- B. Operation Cycles: Not less than 20,000.
- C. Door Curtain Material: Stainless steel.
- D. Door Curtain Slats: Flat profile slats of 1-1/4-inch (32-mm) center-to-center height. SceenGard perforated slats, 25% open area.
- E. Curtain Jamb Guides: Stainless steel with exposed finish matching curtain slats.
- F. Hood: Stainless steel.
1. Mounting: Between jambs.
 2. Mounting: Face of wall.
- G. Integral Frame, Hood, and Fascia for Counter Door: Stainless steel.
1. Mounting: Between jambs at CCD-1.
 2. Mounting: Face of wall at CCD-2.
- H. Sill Configuration for Counter Door: Sill provided by Division 11.
- I. Locking Devices: Equip door with slide bolt.
1. Locking Device Assembly: Single jamb side locking bars, operable from inside.
- J. Manual Door Operator: Push-up operation.
- K. Electric Door Operator:
1. Operator Location: Front of hood.
 2. Motor Exposure: Interior.
 3. Emergency Manual Operation: Push-up type.
 4. Obstruction-Detection Device: Automatic pneumatic sensor edge on bottom bar.
 - a. Sensor Edge Bulb Color: Black.
 5. Remote-Control Station: Interior.

- L. Door Finish:
 - 1. Stainless-Steel finish.

PART 3 - EXECUTION

3.1 EXAMINATION

- A. Examine substrates areas and conditions, with Installer present, for compliance with requirements for substrate construction and other conditions affecting performance of the Work.
- B. Examine locations of electrical connections.
- C. Proceed with installation only after unsatisfactory conditions have been corrected.

3.2 INSTALLATION

- A. Install overhead coiling doors and operating equipment complete with necessary hardware, anchors, inserts, hangers, and equipment supports; according to manufacturer's written instructions and as specified.
- B. Install overhead coiling doors, hoods, and operators at the mounting locations indicated for each door.
- C. Accessibility: Install overhead coiling doors, switches, and controls along accessible routes in compliance with regulatory requirements for accessibility.

3.3 STARTUP SERVICE

- A. Engage a factory-authorized service representative to perform startup service.
 - 1. Perform installation and startup checks according to manufacturer's written instructions.
 - 2. Test and adjust controls and safeties. Replace damaged and malfunctioning controls and equipment.

3.4 ADJUSTING

- A. Adjust hardware and moving parts to function smoothly so that doors operate easily, free of warp, twist, or distortion.
- B. Lubricate bearings and sliding parts as recommended by manufacturer.

3.5 DEMONSTRATION

- A. Engage a factory-authorized service representative to train Owner's maintenance personnel to adjust, operate, and maintain overhead coiling doors.

END OF SECTION 083323

SECTION 084113 - ALUMINUM-FRAMED ENTRANCES AND STOREFRONTS

PART 1 - GENERAL

1.1 RELATED DOCUMENTS

- A. Drawings and general provisions of the Contract, including General and Supplementary Conditions and Division 01 Specification Sections, apply to this Section.

1.2 SUMMARY

- A. Section Includes:

- 1. Exterior storefront window framing.

1.3 PERFORMANCE REQUIREMENTS

- A. General Performance: Aluminum-framed systems shall withstand the effects of the following performance requirements without exceeding performance criteria or failure due to defective manufacture, fabrication, installation, or other defects in construction:

- 1. Movements of supporting structure including, but not limited to, story drift and deflection from uniformly distributed and concentrated live loads.
- 2. Dimensional tolerances of building frame and other adjacent construction.
- 3. Failure includes the following:
 - a. Deflection exceeding specified limits.
 - b. Thermal stresses transferring to building structure.
 - c. Framing members transferring stresses, including those caused by thermal and structural movements to glazing.
 - d. Glazing-to-glazing contact.
 - e. Noise or vibration created by wind and by thermal and structural movements.
 - f. Loosening or weakening of fasteners, attachments, and other components.
 - g. Sealant failure.
 - h. Failure of operating units.

- B. Structural Loads:

- 1. Wind Loads:
 - a. Basic Wind Speed: 120 mph (40 m/s)
 - b. Importance Factor: 1.15
 - c. Exposure Category: C.
- 2. Seismic Loads: As indicated on Drawings.

- C. Deflection of Framing Members:
 - 1. Deflection Normal to Wall Plane: Limited to edge of glass in a direction perpendicular to glass plane shall not exceed $L/175$ of the glass edge length for each individual glazing lite or an amount that restricts edge deflection of individual glazing lites to 3/4 inch (19 mm), whichever is less.
 - 2. Deflection Parallel to Glazing Plane: Limited to $L/360$ of clear span or 1/8 inch (3.2 mm), whichever is smaller.
- D. Structural-Test Performance: Provide aluminum-framed systems tested according to ASTM E 330 as follows:
 - 1. When tested at positive and negative wind-load design pressures, systems do not evidence deflection exceeding specified limits.
 - 2. When tested at 150 percent of positive and negative wind-load design pressures, systems, including anchorage, do not evidence material failures, structural distress, and permanent deformation of main framing members exceeding 0.2 percent of span.
- E. Air Infiltration: Provide aluminum-framed systems with maximum air leakage through fixed glazing and framing areas of 0.06 cfm/sq. ft. (0.03 L/s per sq. m) of fixed wall area when tested according to ASTM E 283 at a minimum static-air-pressure difference of 6.24 lbf/sq. ft. (300 Pa).
- F. Water Penetration under Static Pressure: Provide aluminum-framed systems that do not evidence water penetration through fixed glazing and framing areas when tested according to ASTM E 331 at a minimum static-air-pressure difference of 8.0 lb/sq. ft.
- G. Condensation Resistance: Provide aluminum-framed systems with fixed glazing and framing areas having condensation-resistance factor (CRF) of not less than 53 when tested according to AAMA 1503.

1.4 SUBMITTALS

- A. Product Data: For each type of product indicated. Include construction details, material descriptions, dimensions of individual components and profiles, and finishes for aluminum-framed systems.
- B. Shop Drawings: For aluminum-framed systems. Include plans, elevations, sections, details, and attachments to other work.
 - 1. Include details of provisions for system expansion and contraction and for drainage of moisture in the system to the exterior.
- C. Samples for Color Selection /verification: For units with factory-applied color finishes.
- D. Qualification Data: For qualified Installer.
- E. Warranties: Provide product, color, and finish warranties.

1.5 QUALITY ASSURANCE

- A. Installer Qualifications: Manufacturer's authorized representative who is trained and approved for installation of units required for this Project.
- B. Engineering Responsibility: Prepare data for aluminum-framed systems, including Shop Drawings, based on testing and engineering analysis of manufacturer's standard units in systems similar to those indicated for this Project.
- C. Source Limitations for Aluminum-Framed Systems: Obtain from single source from single manufacturer.

1.6 PROJECT CONDITIONS

- A. Field Measurements: Verify actual locations of structural supports and rough opening sizes for aluminum-framed systems by field measurements before fabrication and indicate measurements on Shop Drawings.

1.7 WARRANTY

- A. Warranty: Manufacturer's standard form in which manufacturer agrees to repair or replace components of aluminum-framed systems that do not comply with requirements or that fail in materials or workmanship within specified warranty period.
 - 1. Failures include, but are not limited to, the following:
 - a. Structural failures including, but not limited to, excessive deflection.
 - b. Noise or vibration caused by thermal movements.
 - c. Deterioration of metals, metal finishes, and other materials beyond normal weathering.
 - d. Adhesive or cohesive sealant failures.
 - e. Water leakage through fixed glazing and framing areas.
 - f. Failure of operating components.
 - 2. Warranty Period: One year from date of Substantial Completion.
- B. Finish Warranty: Manufacturer's standard form in which manufacturer agrees to repair or replace components on which finishes do not comply with requirements or that fail in materials or workmanship within specified warranty period. Warranty does not include normal weathering.

Warranty Period: Five years from date of Substantial Completion.

PART 2 - PRODUCTS

2.1 MANUFACTURERS / PRODUCTS

- A. Manufacturers: Subject to compliance with requirements, provide the following:

1. Storefront Framing: (Window framing)
 - a. Kawneer North America / TRI FAB VG 451 T (Center Plane Glazing).
 - b. Oldcastle / Equivalent Series (Center Plane Glazing)

B. Equivalent products by EFCO are subject to the approval of the Architect.

2.2 MATERIALS

A. Aluminum: Alloy and temper recommended by manufacturer for type of use and finish indicated.

1. Sheet and Plate: ASTM B 209 (ASTM B 209M).
2. Extruded Bars, Rods, Profiles, and Tubes: ASTM B 221 (ASTM B 221M).
3. Extruded Structural Pipe and Tubes: ASTM B 429.
4. Structural Profiles: ASTM B 308/B 308M.
5. Welding Rods and Bare Electrodes: American Welding Society (AWS) AWS A5.10/A5.10M.

B. Steel Reinforcement: Manufacturer's standard zinc-rich, corrosion-resistant primer, complying with Society for Protective Coatings (SSPC) SSPC-PS Guide No. 12.00; applied immediately after surface preparation and pretreatment. Select surface preparation methods according to recommendations in SSPC-SP COM and prepare surfaces according to applicable SSPC standard.

1. Structural Shapes, Plates, and Bars: ASTM A 36/A 36M.
2. Cold-Rolled Sheet and Strip: ASTM A 1008/A 1008M.
3. Hot-Rolled Sheet and Strip: ASTM A 1011/A 1011M.

2.3 FRAMING SYSTEMS

A. Framing Members: Manufacturer's standard extruded-aluminum framing members of thickness required and reinforced as required to support imposed loads.

1. Construction: Thermally broken.
2. Glazing System: Retained mechanically with gaskets on four sides.
3. Glazing Plane: Center glazed system.
4. Sightline: 2 inches
5. Finish: High Performance Organic finish.
6. Fabrication Method: Screw spline

B. Brackets and Reinforcements: Manufacturer's standard high-strength aluminum with non-staining, nonferrous shims for aligning system components.

C. Backer Plates: Manufacturer's standard, continuous backer plates for framing members, if not integral, where framing abuts adjacent construction.

- D. Fasteners and Accessories: Manufacturer's standard corrosion-resistant, nonstaining, nonbleeding fasteners and accessories compatible with adjacent materials.
 - 1. Use self-locking devices where fasteners are subject to loosening or turning out from thermal and structural movements, wind loads, or vibration.
 - 2. Reinforce members as required to receive fastener threads.
 - 3. Use exposed fasteners with countersunk Phillips screw heads, finished to match framing system, fabricated from stainless steel.
- E. Concrete and Masonry Inserts: Hot-dip galvanized cast-iron, malleable-iron, or steel inserts, complying with ASTM A 123/A 123M or ASTM A 153/A 153M.
- F. Concealed Flashing: Manufacturer's standard corrosion-resistant, non-staining, nonbleeding flashing compatible with adjacent materials.
- G. Framing System Gaskets and Sealants: Manufacturer's standard, recommended by manufacturer for joint type.
- H. Framing Systems to include Manufacturer's standard sub-sill at all conditions.

2.4 GLAZING SYSTEMS

- A. Glazing: As specified in Division 08 Section "Glazing."
- B. Glazing Gaskets: Manufacturer's standard compression types; replaceable, molded or extruded, of profile and hardness required to maintain watertight seal.
- C. Spacers and Setting Blocks: Manufacturer's standard elastomeric type.
- D. Bond-Breaker Tape: Manufacturer's standard TFE-fluorocarbon or polyethylene material to which sealants will not develop adhesion.

2.5 ACCESSORY MATERIALS

- A. Joint Sealants: For installation at perimeter of aluminum-framed systems, as specified in Division 07 Section "Joint Sealants."

2.6 FABRICATION

- A. Form or extrude aluminum shapes before finishing.
- B. Weld in concealed locations to greatest extent possible to minimize distortion or discoloration of finish. Remove weld spatter and welding oxides from exposed surfaces by descaling or grinding.
- C. Framing Members, General: Fabricate components that, when assembled, have the following characteristics:
 - 1. Profiles that are sharp, straight, and free of defects or deformations.

2. Accurately fitted joints with ends coped or mitered.
3. Means to drain water passing joints, condensation within framing members, and moisture migrating within the system to exterior.
4. Physical and thermal isolation of glazing from framing members.
5. Accommodations for thermal and mechanical movements of glazing and framing to maintain required glazing edge clearances.
6. Fasteners, anchors, and connection devices that are concealed from view to greatest extent possible.

D. Mechanically Glazed Framing Members: Fabricate for flush glazing without projecting stops.

E. Storefront Framing: Fabricate components for assembly using screw spline system.

2.7 ALUMINUM FINISHES

A. High-Performance Organic Finish: Two-coat minimum fluoropolymer finish complying with AAMA 2604 or AAMA 2605 and containing not less than 70 percent PVDF or FEVE resin by weight in color coat. Prepare, pretreat, and apply coating to exposed metal surfaces to comply with coating and resin manufacturers' written instructions.

1. Color: White, as selected by Architect from manufacturer's full range.

PART 3 - EXECUTION

3.1 EXAMINATION

- A. Examine areas and conditions, with Installer present, for compliance with requirements for installation tolerances and other conditions affecting performance of the Work.
- B. Proceed with installation only after unsatisfactory conditions have been corrected.

3.2 INSTALLATION

A. General:

1. Comply with manufacturer's written instructions.
2. Do not install damaged components.
3. Fit joints to produce hairline joints free of burrs and distortion.
4. Rigidly secure non-movement joints.
5. Install anchors with separators and isolators to prevent metal corrosion and electrolytic deterioration.
6. Seal joints watertight unless otherwise indicated.

B. Metal Protection:

1. Where aluminum will contact dissimilar metals, protect against galvanic action by painting contact surfaces with primer or applying sealant or tape, or by installing nonconductive spacers as recommended by manufacturer for this purpose.
 2. Where aluminum will contact concrete or masonry, protect against corrosion by painting contact surfaces with bituminous paint.
- C. Install components to drain water passing joints, condensation occurring within framing members, and moisture migrating within the system to exterior.
- D. Set continuous sill members and flashing in full sealant bed as specified in Division 07 Section "Joint Sealants" to produce weathertight installation.
- E. Install components plumb and true in alignment with established lines and grades, and without warp or rack.
- F. Install glazing as instructed by framing manufacturer.
- G. Install perimeter joint sealants as specified in Division 07 Section "Joint Sealants" to produce weathertight installation.
- H. Clean and protect aluminum surfaces until completion of other work.

3.3 ERECTION TOLERANCES

- A. Install aluminum-framed systems to comply with the following maximum erection tolerances:
1. Location and Plane: Limit variation from true location and plane to 1/8 inch in 12 feet (3 mm in 3.7 m); 1/4 inch (6 mm) over total length.
 2. Alignment:
 - a. Where surfaces abut in line, limit offset from true alignment to 1/16 inch (1.5 mm).
 - b. Where surfaces meet at corners, limit offset from true alignment to 1/32 inch (0.8 mm).
- B. Diagonal Measurements: Limit difference between diagonal measurements to 1/8 inch (3 mm).

END OF SECTION 084113

THIS PAGE INTENTIONALLY BLANK

SECTION 084523 – TRANSLUCENT FIBERGLASS SANDWICH PANEL ASSEMBLIES

PART 1 - GENERAL

1.1 SUMMARY

- A. Section includes the insulated translucent wall panel system as shown and specified. Work includes providing and installing:
 - 1. Flat, factory prefabricated, structural insulated translucent sandwich panel assembly for roof application.

1.2 SUBMITTALS

- A. Submit manufacturer's product data and qualifications. Include construction details, material descriptions, profiles and finishes of roof panel components and documentation related to product manufacturer qualification requirements in Paragraph 1.3.A.
- B. Submit shop drawings with attachment details.
- C. Submit samples for each exposed finish required, in same thickness and material indicated for the work and in size indicated below.
 - 1. Sandwich panels: 14" x 28" sample unit.
 - 2. Factory finished aluminum: 5" long sample section.
- D. Submit Installer Qualification Certificate, signed by installer, certifying compliance with project installer qualification requirements in Paragraph 1.3.B.
- E. Submit product test reports from a qualified independent testing agency indicating each type and class of panel system complies with the project performance requirements, based on comprehensive testing of current products. Previously completed test reports will be acceptable if for current manufacturer and indicative of products used on this project.
 - 1. Test reports required are:
 - a. Flame Spread and Smoke Developed (UL 723) – Submit UL Card
 - b. Burn Extent (ASTM D 635)
 - c. Color Difference (ASTM D 2244)
 - d. Abrasion/Erosion Resistance (ASTM D 4060)
 - e. Impact Strength (UL 972)
 - f. Bond Tensile Strength (ASTM C 297 after aging by ASTM D 1037)
 - g. Bond Shear Strength (ASTM D 1002)
 - h. Insulation U-Factor (NFRC 100)
 - i. NFRC System U-Factor Certification
 - j. Solar Heat Gain Coefficient
 - k. Condensation Resistance Factor (AAMA 1503)

- l. Air Leakage (ASTM E 283)
- m. Structural Performance (ASTM E 330)
- n. Water Penetration (ASTM E 331)

F. Submit current documentation indicating regular, independent quality control monitoring under a nationally recognized building code review and listing program.

1.3 QUALITY ASSURANCE

A. Manufacturer's Qualifications.

1. Material and products shall be manufactured by a company continuously and regularly employed in the manufacture of specified materials for a period of at least ten (10) consecutive years and which can show evidence of those materials being satisfactorily used on at least six (6) projects of similar size, scope and location. At least three (3) of the projects shall have been in successful use for ten (10) years or longer.
2. Panel system must be listed by the International Code Council – Evaluation Service (ICC-ES) which requires quality control inspections and fire, structural and water infiltration testing of sandwich panel systems by an approved agency.
3. Quality control inspections shall be conducted at least once each year and shall include manufacturing facilities, sandwich panel components and production sandwich panels for conformance with “Acceptance Criteria for Sandwich Panels” as regulated by the ICC-ES.

B. Installer’s Qualifications: Installation shall be by an experienced installer, which has been in the business of installing specified wall panel systems for at least five (5) consecutive years and can show evidence of satisfactory completion of projects of similar size, scope and type.

1.4 DESIGN

A. Roof Panel System: Multiple attached panels. Rectangular assembly size per Drawings. ¼ inch per foot slope.

B. Design Loads:

1. Wind Loading: Exposure C, 120 mph, $I_w=1.15$.
2. Wind uplift 27 PSF, snow load 26 PSF. Refer to Structural Drawings.

1.5 DELIVERY STORAGE AND HANDLING

A. Deliver panel system, components and materials in manufacturer's standard protective packaging.

B. Store panels on the long edge; several inches above the ground; blocked and under cover in accordance with manufacturer's storage and handling instructions.

1.6 WARRANTY

- A. Submit manufacturer's and installer's written warranty agreeing to repair or replace panel system work which fails in materials or workmanship within one (1) year of the date of delivery. Failure of materials or workmanship shall include leakage, excessive deflection, and deterioration of finish on metal in excess of normal weathering and defects in accessories, insulated translucent sandwich panels and other components of the work.

PART 2 - PRODUCTS

2.1 MANUFACTURER

- A. Subject to compliance with requirements, provide roof panel products by the following:
 - 1. Kalwall Corporation.
 - 2. Equivalent products by other manufacturers are subject to Architect approval prior to bid.

2.2 PANEL COMPONENTS

A. Face Sheets

- 1. Translucent faces: Manufactured from glass fiber reinforced thermoset resins, formulated specifically for architectural use.
 - a. Thermoplastic (e.g. polycarbonate, acrylic) faces are not acceptable.
 - b. Face sheets shall not deform, deflect or drip when subjected to fire or flame.
 - c. Face sheets shall not delaminate when exposed to 200°F for 30 minutes per IBC or 300°F for 25 minutes.
- 2. Interior face sheets:
 - a. Flamespread: Underwriters Laboratories (UL) listed, which requires periodic unannounced retesting, with flamespread rating no greater than 50 and smoke developed no greater than 250 when tested in accordance with UL 723/ASTM E 84.
 - b. Burn extent by ASTM D 635 shall be no greater than 1”.
- 3. Exterior face sheets:
 - a. Color stability: Full thickness of the exterior face sheet shall not change color more than 3.0 CIE Units DELTA E by ASTM D 2244 after 5 years (outdoor South Florida weathering at 5° facing south, determined by the average of at least three (3) white samples with and without a protective film or coating to ensure long-term color stability. Color stability shall be unaffected by abrasion or scratching.
 - b. Erosion Resistance: Exterior face shall have a permanent glass erosion barrier embedded beneath the surface to provide long-term resistance to reinforcing fiber exposure. Exterior face surface loss shall not exceed 7 mils and 40 mgs when tested in accordance with ASTM D 4060 employing CS17 abrasive wheels at a head load of 500 grams for 1000 cycles.

- c. Strength: Exterior face sheet shall be uniform in strength, impenetrable by handheld pencil and repel an impact equal to 70 (230) ft. lbs. without fracture or tear when impacted by a 3-1/4" diameter, 5 lb. free-falling ball per UL 972.
 - 4. Appearance and Thickness:
 - a. Exterior face sheets: Smooth, 0.070" thick and crystal in color.
 - b. Interior face sheets: Smooth, 0.045" thick and crystal in color.
 - c. Face sheets shall not vary more than +/- 10% in thickness and be uniform in color.
- B. Grid Core
 - 1. Thermally broken (aluminum) I-beam grid core shall be of 6063-T6 or 6005-T5 alloy and temper with provisions for mechanical interlocking of muntin-mullion and perimeter. Width of I-beam shall be no less than 7/16". The I-beam grid shall be machined to tolerances of not greater than +/- .002".
 - 2. Thermal break: Minimum 1"; thermoset. Urethane poured and de-bridged is not acceptable.
- C. Laminate Adhesive
 - 1. Heat and pressure resin type adhesive engineered for structural sandwich panel use, with minimum 25-years field use. Adhesive shall pass testing requirements specified by the International Code Council "Acceptance Criteria for Sandwich Panel Adhesives."
 - 2. Minimum tensile strength of 750 PSI when the panel assembly is tested by ASTM C 297 after two (2) exposures to six (6) cycles each of the aging conditions prescribed by ASTM D 1037.
 - 3. Minimum shear strength of the panel adhesive by ASTM D 1002 after exposure to five (5) separate conditions:
 - a. 50% Relative Humidity at 68° F: 540 PSI.
 - b. 182° F: 100 PSI.
 - c. Accelerated Aging by ASTM D 1037 at room temperature: 800 PSI.
 - d. Accelerated Aging by ASTM D 1037 at 182° F: 250 PSI.

2.3 PANEL CONSTRUCTION

- A. Provide sandwich panels of flat fiberglass reinforced translucent face sheets laminated to a grid core of mechanically interlocking thermally broken (aluminum) I-beams. The adhesive bonding line shall be straight, cover the entire width of the I-beam and have a neat, sharp edge.
 - 1. Thickness: 2-3/4"
 - 2. Light transmission: 30%
 - 3. Solar heat gain coefficient: 0.29.
 - 4. Overall panel U- factor by NFRC certified laboratory: 2-3/4" thermally broken I-beam, 0.29.
 - 5. Grid pattern: Nominal 1'-0" wide x 1'-5" high. Refer to Drawings. Grid color black.

- B. Panels shall deflect no more than 1.9” at 30 psf in 10’-0” span without a supporting frame by ASTM E 72.
- C. Panels shall show evidence of withstanding 1200°F fire for minimum one (1) hour without collapse or-flame penetration.
- D. Thermally broken panels:
 - 1. Minimum Condensation Resistance Factor of 80 by AAMA 1503 measured on the bond line.
 - 2. Minimum CRF of 90 at center of grid cell.

2.4 BATTENS AND PERIMETER CLOSURE SYSTEMS

- A. Closure system and vertical battens: Extruded aluminum 6063-T6 and 6063-T5 alloy and temper clamp-tite screw type closure system.
- B. Sealing tape: Manufacturer's standard, pre-applied to closure system at the factory under controlled conditions.
- C. Fasteners: 300 series stainless steel screws for aluminum closures, excluding final fasteners to the building.
- D. Finish: Exposed aluminum to be manufacturer’s factory applied finish that meets the performance requirements of AAMA 2604. (Mill)
 - 1. Color: Mill finish aluminum.

PART 3 - EXECUTION

3.1 EXAMINATION

- A. Examine substrates, supporting structure and installation conditions. Do not proceed with system erection until unsatisfactory conditions have been corrected.

3.2 PREPARATION

- A. Metal Protection:
 - 1. Where aluminum will contact dissimilar metals, protect against galvanic action by painting surfaces with primer or by applying sealant or tape recommended by manufacturer for this purpose.
 - 2. Where aluminum will contact concrete or masonry, protect against corrosion by painting contact surfaces with bituminous paint or method recommended by manufacturer.

3.3 INSTALLATION

- A. Install the roof panel system in accordance with the manufacturer's installation recommendations and approved shop drawings.
 - 1. Anchor component parts securely in place by permanent mechanical attachment system.
 - 2. Accommodate thermal and mechanical movements.
 - 3. Set sill and curb members in a full bed of sealant compound, or with joint fillers or gaskets to provide weather-tight construction.
- B. Install joint sealants at perimeter joints and within the panel system in strict accordance with manufacturer's installation instructions.

3.4 CLEANING

- A. Clean the roof panel system inside and outside, immediately after installation, according to manufacturer's written recommendations.

END OF SECTION 084523

SECTION 087100 - DOOR HARDWARE

PART 1 - GENERAL

1.1 RELATED DOCUMENTS

- A. Drawings and general provisions of the Contract, including General and Supplementary Conditions and Division 1 Specification Sections, apply to this Section.

1.2 SUMMARY

- A. This Section includes commercial door hardware for the following:
 - 1. Swinging doors.
 - 2. Other doors to the extent indicated.
- B. Door hardware includes, but is not necessarily limited to, the following:
 - 1. Mechanical door hardware.
 - 2. Electromechanical door hardware.
 - 3. Cylinders specified for doors in other sections.
- C. Related Sections:
 - 1. Division 08 Section "Hollow Metal Doors and Frames".
 - 2. Division 08 Section "Flush Wood Doors".
 - 3. Division 28 Section "Access Control Hardware Devices".
- D. Codes and References: Comply with the version year adopted by the Authority Having Jurisdiction.
 - 1. ANSI A117.1 - Accessible and Usable Buildings and Facilities.
 - 2. ICC/IBC - International Building Code.
 - 3. NFPA 70 - National Electrical Code.
 - 4. NFPA 80 - Fire Doors and Windows.
 - 5. NFPA 101 - Life Safety Code.
 - 6. NFPA 105 - Installation of Smoke Door Assemblies.
 - 7. State Building Codes, Local Amendments.
- E. Standards: All hardware specified herein shall comply with the following industry standards as applicable. Any undated reference to a standard shall be interpreted as referring to the latest edition of that standard:
 - 1. ANSI/BHMA Certified Product Standards - A156 Series.
 - 2. UL10C - Positive Pressure Fire Tests of Door Assemblies.

3. ANSI/UL 294 - Access Control System Units.
4. UL 305 - Panic Hardware.
5. ANSI/UL 437- Key Locks.

1.3 SUBMITTALS

- A. Product Data: Manufacturer's product data sheets including installation details, material descriptions, dimensions of individual components and profiles, operational descriptions and finishes.
- B. Door Hardware Schedule: Prepared by or under the supervision of supplier, detailing fabrication and assembly of door hardware, as well as procedures and diagrams. Coordinate the final Door Hardware Schedule with doors, frames, and related work to ensure proper size, thickness, hand, function, and finish of door hardware.
 1. Format: Comply with scheduling sequence and vertical format in DHI's "Sequence and Format for the Hardware Schedule."
 2. Organization: Organize the Door Hardware Schedule into door hardware sets indicating complete designations of every item required for each door or opening. Organize door hardware sets in same order as in the Door Hardware Sets at the end of Part 3. Submittals that do not follow the same format and order as the Door Hardware Sets will be rejected and subject to resubmission.
 3. Content: Include the following information:
 - a. Type, style, function, size, label, hand, and finish of each door hardware item.
 - b. Manufacturer of each item.
 - c. Fastenings and other pertinent information.
 - d. Location of door hardware set, cross-referenced to Drawings, both on floor plans and in door and frame schedule.
 - e. Explanation of abbreviations, symbols, and codes contained in schedule.
 - f. Mounting locations for door hardware.
 - g. Door and frame sizes and materials.
 - h. Warranty information for each product.
 4. Submittal Sequence: Submit the final Door Hardware Schedule at earliest possible date, particularly where approval of the Door Hardware Schedule must precede fabrication of other work that is critical in the Project construction schedule. Include Product Data, Samples, Shop Drawings of other work affected by door hardware, and other information essential to the coordinated review of the Door Hardware Schedule.
- C. Shop Drawings: Details of electrified access control hardware indicating the following:
 1. Wiring Diagrams: Upon receipt of approved schedules, submit detailed system wiring diagrams for power, signaling, monitoring, communication, and control of the access control system electrified hardware. Differentiate between manufacturer-installed and field-installed wiring. Include the following:

- a. Elevation diagram of each unique access controlled opening showing location and interconnection of major system components with respect to their placement in the respective door openings.
 - b. Complete (risers, point-to-point) access control system block wiring diagrams.
 - c. Wiring instructions for each electronic component scheduled herein.
 2. Electrical Coordination: Coordinate with related sections the voltages and wiring details required at electrically controlled and operated hardware openings.
- D. Keying Schedule: After a keying meeting with the owner has taken place prepare a separate keying schedule detailing final instructions. Submit the keying schedule in electronic format. Include keying system explanation, door numbers, key set symbols, hardware set numbers and special instructions. Owner must approve submitted keying schedule prior to the ordering of permanent cylinders/cores.
- E. Informational Submittals:
1. Product Test Reports: Indicating compliance with cycle testing requirements, based on evaluation of comprehensive tests performed by manufacturer and witnessed by a qualified independent testing agency.
- F. Operating and Maintenance Manuals: Provide manufacturers operating and maintenance manuals for each item comprising the complete door hardware installation in quantity as required in Division 01, Closeout Procedures.
- 1.4 QUALITY ASSURANCE
- A. Manufacturers Qualifications: Engage qualified manufacturers with a minimum 5 years of documented experience in producing hardware and equipment similar to that indicated for this Project and that have a proven record of successful in-service performance.
 - B. Certified Products: Where specified, products must maintain a current listing in the Builders Hardware Manufacturers Association (BHMA) Certified Products Directory (CPD).
 - C. Installer Qualifications: A minimum 3 years documented experience installing both standard and electrified door hardware similar in material, design, and extent to that indicated for this Project and whose work has resulted in construction with a record of successful in-service performance.
 - D. Door Hardware Supplier Qualifications: Experienced commercial door hardware distributors with a minimum 5 years documented experience supplying both mechanical and electromechanical hardware installations comparable in material, design, and extent to that indicated for this Project. Supplier recognized as a factory direct distributor by the manufacturers of the primary materials with a warehousing facility in Project's vicinity. Supplier to have on staff a certified Architectural Hardware Consultant (AHC) available during the course of the Work to consult with Contractor, Architect, and Owner concerning both standard and electromechanical door hardware and keying.

- E. Source Limitations: Obtain each type and variety of door hardware specified in this section from a single source unless otherwise indicated.
 - 1. Electrified modifications or enhancements made to a source manufacturer's product line by a secondary or third party source will not be accepted.
 - 2. Provide electromechanical door hardware from the same manufacturer as mechanical door hardware, unless otherwise indicated.
- F. Each unit to bear third party permanent label demonstrating compliance with the referenced standards.
- G. Keying Conference: Conduct conference to comply with requirements in Division 01 Section "Project Meetings." Keying conference to incorporate the following criteria into the final keying schedule document:
 - 1. Function of building, purpose of each area and degree of security required.
 - 2. Plans for existing and future key system expansion.
 - 3. Requirements for key control storage and software.
 - 4. Installation of permanent keys, cylinder cores and software.
 - 5. Address and requirements for delivery of keys.
- H. Pre-Submittal Conference: Conduct coordination conference in compliance with requirements in Division 01 Section "Project Meetings" with attendance by representatives of Supplier(s), Installer(s), and Contractor(s) to review proper methods and the procedures for receiving, handling, and installing door hardware.
 - 1. Prior to installation of door hardware, conduct a project specific training meeting to instruct the installing contractors' personnel on the proper installation and adjustment of their respective products. Product training to be attended by installers of door hardware (including electromechanical hardware) for aluminum, hollow metal and wood doors. Training will include the use of installation manuals, hardware schedules, templates and physical product samples as required.
 - 2. Inspect and discuss electrical roughing-in, power supply connections, and other preparatory work performed by other trades.
 - 3. Review sequence of operation narratives for each unique access controlled opening.
 - 4. Review and finalize construction schedule and verify availability of materials.
 - 5. Review the required inspecting, testing, commissioning, and demonstration procedures
- I. At completion of installation, provide written documentation that components were applied to manufacturer's instructions and recommendations and according to approved schedule.

1.5 DELIVERY, STORAGE, AND HANDLING

- A. Inventory door hardware on receipt and provide secure lock-up and shelving for door hardware delivered to Project site. Do not store electronic access control hardware, software or accessories at Project site without prior authorization.

- B. Tag each item or package separately with identification related to the final Door Hardware Schedule, and include basic installation instructions with each item or package.
- C. Deliver, as applicable, permanent keys, cylinders, cores, access control credentials, software and related accessories directly to Owner via registered mail or overnight package service. Instructions for delivery to the Owner shall be established at the "Keying Conference".

1.6 COORDINATION

- A. Templates: Obtain and distribute to the parties involved templates for doors, frames, and other work specified to be factory prepared for installing standard and electrified hardware. Check Shop Drawings of other work to confirm that adequate provisions are made for locating and installing hardware to comply with indicated requirements.
- B. Door and Frame Preparation: Doors and corresponding frames are to be prepared, reinforced and pre-wired (if applicable) to receive the installation of the specified electrified, monitoring, signaling and access control system hardware without additional in-field modifications.

1.7 WARRANTY

- A. General Warranty: Reference Division 01, General Requirements. Special warranties specified in this Article shall not deprive Owner of other rights Owner may have under other provisions of the Contract Documents and shall be in addition to, and run concurrent with, other warranties made by Contractor under requirements of the Contract Documents.
- B. Warranty Period: Written warranty, executed by manufacturer(s), agreeing to repair or replace components of standard and electrified door hardware that fails in materials or workmanship within specified warranty period after final acceptance by the Owner. Failures include, but are not limited to, the following:
 - 1. Structural failures including excessive deflection, cracking, or breakage.
 - 2. Faulty operation of the hardware.
 - 3. Deterioration of metals, metal finishes, and other materials beyond normal weathering.
 - 4. Electrical component defects and failures within the systems operation.
- C. Warranty Period: Unless otherwise indicated, warranty shall be one year from date of Substantial Completion.

1.8 MAINTENANCE SERVICE

- A. Maintenance Tools and Instructions: Furnish a complete set of specialized tools and maintenance instructions as needed for Owner's continued adjustment, maintenance, and removal and replacement of door hardware.

PART 2 - PRODUCTS

2.1 SCHEDULED DOOR HARDWARE

- A. General: Provide door hardware for each door to comply with requirements in Door Hardware Sets and each referenced section that products are to be supplied under.
- B. Designations: Requirements for quantity, item, size, finish or color, grade, function, and other distinctive qualities of each type of door hardware are indicated in the Door Hardware Sets at the end of Part 3. Products are identified by using door hardware designations, as follows:
 - 1. Named Manufacturer's Products: Product designation and manufacturer are listed for each door hardware type required for the purpose of establishing requirements. Manufacturers' names are abbreviated in the Door Hardware Schedule.
- C. Substitutions: Requests for substitution and product approval for inclusive mechanical and electromechanical door hardware in compliance with the specifications must be submitted in writing and in accordance with the procedures and time frames outlined in Division 01, Substitution Procedures. Approval of requests is at the discretion of the architect, owner, and their designated consultants.

2.2 HANGING DEVICES

- A. Hinges: ANSI/BHMA A156.1 butt hinges with number of hinge knuckles and other options as specified in the Door Hardware Sets.
 - 1. Quantity: Provide the following hinge quantity:
 - a. Two Hinges: For doors with heights up to 60 inches.
 - b. Three Hinges: For doors with heights 61 to 90 inches.
 - c. Four Hinges: For doors with heights 91 to 120 inches.
 - d. For doors with heights more than 120 inches, provide 4 hinges, plus 1 hinge for every 30 inches of door height greater than 120 inches.
 - 2. Hinge Size: Provide the following, unless otherwise indicated, with hinge widths sized for door thickness and clearances required:
 - a. Widths up to 3'0": 4-1/2" standard or heavy weight as specified.
 - b. Sizes from 3'1" to 4'0": 5" standard or heavy weight as specified.
 - 3. Hinge Weight and Base Material: Unless otherwise indicated, provide the following:
 - a. Exterior Doors: Heavy weight, non-ferrous, ball bearing or oil impregnated bearing hinges unless Hardware Sets indicate standard weight.
 - b. Interior Doors: Standard weight, steel, ball bearing or oil impregnated bearing hinges unless Hardware Sets indicate heavy weight.
 - 4. Hinge Options: Comply with the following:

- a. Non-removable Pins: With the exception of electric through wire hinges, provide set screw in hinge barrel that, when tightened into a groove in hinge pin, prevents removal of pin while door is closed; for the all out-swinging lockable doors.

5. Manufacturers:

- a. Hager Companies (HA) - BB Series, 5 knuckle.
- b. McKinney (MK) - TA/T4A Series, 5 knuckle.

2.3 POWER TRANSFER DEVICES

- A. Electric Door Wire Harnesses: Provide electric/data transfer wiring harnesses with standardized plug connectors to accommodate up to twelve (12) wires. Connectors plug directly to through-door wiring harnesses for connection to electric locking devices and power supplies. Provide sufficient number and type of concealed wires to accommodate electric function of specified hardware. Provide a connector for through-door electronic locking devices and from hinge to junction box above the opening. Wire nut connections are not acceptable. Determine the length required for each electrified hardware component for the door type, size and construction, minimum of two per electrified opening.

1. Provide one each of the following tools as part of the base bid contract:

- a. McKinney (MK) - Electrical Connecting Kit: QC-R001.
- b. McKinney (MK) - Connector Hand Tool: QC-R003.

2. Manufacturers:

- a. Hager Companies (HA) - Quick Connect.
- b. McKinney (MK) - QC-C Series.

2.4 DOOR OPERATING TRIM

- A. Flush Bolts and Surface Bolts: Provide products conforming to ANSI/BHMA A156.3 and A156.16, Grade 1.

1. Flush bolts to be furnished with top rod of sufficient length to allow bolt retraction device location approximately six feet from the floor.
2. Furnish dust proof strikes for bottom bolts.
3. Surface bolts to be minimum 8" in length and U.L. listed for labeled fire doors and U.L. listed for windstorm components where applicable.
4. Provide related accessories (mounting brackets, strikes, coordinators, etc.) as required for appropriate installation and operation.

5. Manufacturers:

- a. Door Controls International (DC).
- b. Rockwood (RO).
- c. Trimco (TC).

- B. Door Push Plates and Pulls: ANSI/BHMA A156.6 door pushes and pull units of type and design specified in the Hardware Sets. Coordinate and provide proper width and height as required where conflicting hardware dictates.
1. Push/Pull Plates: Minimum .050 inch thick, size as indicated in hardware sets, with beveled edges, secured with exposed screws unless otherwise indicated.
 2. Door Pull and Push Bar Design: Size, shape, and material as indicated in the hardware sets. Minimum clearance of 2 1/2-inches from face of door unless otherwise indicated.
 3. Offset Pull Design: Size, shape, and material as indicated in the hardware sets. Minimum clearance of 2 1/2-inches from face of door and offset of 90 degrees unless otherwise indicated.
 4. Pulls, where applicable, shall be provided with a 10" clearance from the finished floor on the push side to accommodate wheelchair accessibility.
 5. Fasteners: Provide manufacturer's designated fastener type as indicated in Hardware Sets.
 6. Manufacturers:
 - a. Hiawatha, Inc. (HI).
 - b. Rockwood (RO).
 - c. Trimco (TC).

2.5 CYLINDERS AND KEYING

- A. General: Cylinder manufacturer to have minimum (10) years experience designing secured master key systems and have on record a published security keying system policy.
- B. Cylinder Types: Original manufacturer cylinders able to supply the following cylinder formats and types:
1. Threaded mortise cylinders with rings and cams to suit hardware application.
 2. Rim cylinders with back plate, flat-type vertical or horizontal tailpiece, and raised trim ring.
 3. Bored or cylindrical lock cylinders with tailpieces as required to suit locks.
 4. Tubular deadlocks and other auxiliary locks.
 5. Mortise and rim cylinder collars to be solid and recessed to allow the cylinder face to be flush and be free spinning with matching finishes.
 6. Keyway: Match Facility Standard.
- C. Keying System: Each type of lock and cylinders to be factory keyed.
1. Supplier shall conduct a "Keying Conference" to define and document keying system instructions and requirements.
 2. Furnish factory cut, nickel-silver large bow permanently inscribed with a visual key control number as directed by Owner.
 3. Existing System: Field verify and key cylinders to match Owner's existing system.
- D. Key Quantity: Provide the following minimum number of keys:
1. Change Keys per Cylinder: Two (2)

2. Master Keys (per Master Key Level/Group): Five (5).
3. Construction Keys (where required): Ten (10).

E. Construction Keying: Provide construction master keyed cylinders.

F. Key Registration List (Bitting List):

1. Provide keying transcript list to Owner's representative in the proper format for importing into key control software.
2. Provide transcript list in writing or electronic file as directed by the Owner.

2.6 KEY CONTROL

A. Key Control Cabinet: Provide a key control system including envelopes, labels, and tags with self-locking key clips, receipt forms, 3-way visible card index, temporary markers, permanent markers, and standard metal cabinet. Key control cabinet shall have expansion capacity of 150% of the number of locks required for the project.

1. Manufacturers:

- a. Lund Equipment (LU).
- b. MMF Industries (MM).
- c. Telkee (TK).

P. Electronic Key Management System: Provide an electronic key control system with Stand-alone Plug and Play features including advanced RFID technology. Touchscreen interface with PIN access for keys individually locked in place. Minimum 1,000 system users and 21 iFobs for locking receptors. System shall have a minimum 250,000 audit events screen displayed or ability to be exported via USB port.

1. Manufacturers:

- a. Medeco (MC).
- b. Traka (TA).

2.7 MECHANICAL LOCKS AND LATCHING DEVICES

A. Mortise Locksets, Grade 1 (Heavy Duty): ANSI/BHMA A156.13, Series 1000, Operational Grade 1 Certified Products Directory (CPD) listed. Locksets are to be manufactured with a corrosion resistant steel case and be field-reversible for handing without disassembly of the lock body.

1. Heavy duty mortise locks shall have a ten-year warranty.
2. Where specified, provide status indicators with highly reflective color and wording for "locked/unlocked" or "vacant/occupied" with custom wording options if required. Indicator to be located above the cylinder with the inside thumb-turn not blocking the visibility of the indicator status. Indicator window size to be a minimum of 2.1" x 0.6"

with a curved design allowing a 180-degree viewing angle with protective covering to prevent tampering.

3. Manufacturers:

- a. Sargent Manufacturing (SA) - 8200 Series.
- b. No Substitution.

B. Cylindrical Locksets, Grade 1 (Heavy Duty): ANSI/BHMA A156.2, Series 4000, Operational Grade 1 Certified Products Directory (CPD) listed.

1. Vertical Impact: Exceed 100 vertical impacts (20 times ANSI/BHMA A156.2 requirements).
2. Furnish with solid cast levers, standard 2 3/4" backset, and 1/2" (3/4" at rated paired openings) throw brass or stainless steel latchbolt.
3. Locks are to be non-handed and fully field reversible.
4. Manufacturers:
 - a. Sargent Manufacturing (SA) - 10X Line.
 - b. No Substitution.

2.8 LOCK AND LATCH STRIKES

A. Strikes: Provide manufacturer's standard strike with strike box for each latch or lock bolt, with curved lip extended to protect frame, finished to match door hardware set, unless otherwise indicated, and as follows:

1. Flat-Lip Strikes: For locks with three-piece antifriction latchbolts, as recommended by manufacturer.
2. Extra-Long-Lip Strikes: For locks used on frames with applied wood casing trim.
3. Aluminum-Frame Strike Box: Provide manufacturer's special strike box fabricated for aluminum framing.
4. Double-lipped strikes: For locks at double acting doors. Furnish with retractable stop for rescue hardware applications.

B. Standards: Comply with the following:

1. Strikes for Mortise Locks and Latches: BHMA A156.13.
2. Strikes for Bored Locks and Latches: BHMA A156.2.
3. Strikes for Auxiliary Deadlocks: BHMA A156.36.
4. Dustproof Strikes: BHMA A156.16.

2.9 ELECTRIC STRIKES

- A. Standard Electric Strikes: Electric strikes conforming to ANSI/BHMA A156.31, Grade 1, for use on non-rated or fire rated openings. Strikes shall be of stainless steel construction tested to a minimum of 1500 pounds of static strength and 70 foot-pounds of dynamic strength with a minimum endurance of 1 million operating cycles. Provide strikes with 12 or 24 VDC capability, fail-secure unless otherwise specified. Where specified provide latchbolt and latchbolt strike monitoring indicating both the position of the latchbolt and locked condition of the strike.
1. Manufacturers:
 - a. HES (HS) - 1006 Series.
 - b. HES (HS) - 1500/1600 Series.
- B. Surface Mounted Rim Electric Strikes: Surface mounted rim exit device electric strikes conforming to ANSI/BHMA A156.31, Grade 1, and UL Listed for both Burglary Resistance and for use on fire rated door assemblies. Construction includes internally mounted solenoid with two heavy-duty, stainless steel locking mechanisms operating independently to provide tamper resistance. Strikes tested for a minimum of 500,000 operating cycles. Provide strikes with 12 or 24 VDC capability supplied standard as fail-secure unless otherwise specified. Option available for latchbolt and latchbolt strike monitoring indicating both the position of the latchbolt and locked condition of the strike. Strike requires no cutting to the jamb prior to installation.
1. Manufacturers:
 - a. Folger Adam (FO) - 310-4 Series.
 - b. HES (HS) - 9400/9500/9600/9700/9800 Series.
- C. Provide electric strikes with in-line power controller and surge suppressor by the same manufacturer as the strike with the combined products having a five year warranty.

2.10 CONVENTIONAL EXIT DEVICES

- A. General Requirements: All exit devices specified herein shall meet or exceed the following criteria:
1. Exit devices shall have a five-year warranty.
 2. At doors not requiring a fire rating, provide devices complying with NFPA 101 and listed and labeled for "Panic Hardware" according to UL305. Provide proper fasteners as required by manufacturer including sex nuts and bolts at openings specified in the Hardware Sets.
 3. Where exit devices are required on fire rated doors, provide devices complying with NFPA 80 and with UL labeling indicating "Fire Exit Hardware". Provide devices with the proper fasteners for installation as tested and listed by UL. Consult manufacturer's catalog and template book for specific requirements.

4. Except on fire rated doors, provide exit devices with hex key dogging device to hold the pushbar and latch in a retracted position. Provide optional keyed cylinder dogging on devices where specified in Hardware Sets.
 5. Devices must fit flat against the door face with no gap that permits unauthorized dogging of the push bar. The addition of filler strips is required in any case where the door light extends behind the device as in a full glass configuration.
 6. Lever Operating Trim: Where exit devices require lever trim, furnish manufacturer's heavy duty escutcheon trim with threaded studs for thru-bolts.
 - a. Lock Trim Design: As indicated in Hardware Sets, provide finishes and designs to match that of the specified locksets.
 - b. Where function of exit device requires a cylinder, provide a cylinder (Rim or Mortise) as specified in Hardware Sets.
 7. Vertical Rod Exit Devices: Where surface or concealed vertical rod exit devices are used at interior openings, provide as less bottom rod (LBR) unless otherwise indicated. Provide dust proof strikes where thermal pins are required to project into the floor.
 8. Narrow Stile Applications: At doors constructed with narrow stiles, or as specified in Hardware Sets, provide devices designed for maximum 2" wide stiles.
 9. Dummy Push Bar: Nonfunctioning push bar matching functional push bar.
 10. Rail Sizing: Provide exit device rails factory sized for proper door width application.
 11. Through Bolt Installation: For exit devices and trim as indicated in Door Hardware Sets.
- B. Conventional Push Rail Exit Devices (Heavy Duty): ANSI/BHMA A156.3, Grade 1 Certified Products Directory (CPD) listed panic and fire exit hardware devices furnished in the functions specified in the Hardware Sets. Exit device latch to be stainless steel, pullman type, with deadlock feature.
1. Manufacturers:
 - a. Corbin Russwin Hardware (RU) - ED4000 / ED5000 Series.
 - b. Sargent Manufacturing (SA) - 80 Series.

2.11 DOOR CLOSERS

- A. All door closers specified herein shall meet or exceed the following criteria:
1. General: Door closers to be from one manufacturer, matching in design and style, with the same type door preparations and templates regardless of application or spring size. Closers to be non-handed with full sized covers.
 2. Standards: Closers to comply with UL-10C for Positive Pressure Fire Test and be U.L. listed for use of fire rated doors.

3. Size of Units: Comply with manufacturer's written recommendations for sizing of door closers depending on size of door, exposure to weather, and anticipated frequency of use. Where closers are indicated for doors required to be accessible to the Americans with Disabilities Act, provide units complying with ANSI ICC/A117.1.
 4. Closer Arms: Provide heavy duty, forged steel closer arms unless otherwise indicated in Hardware Sets.
 5. Closers shall not be installed on exterior or corridor side of doors; where possible install closers on door for optimum aesthetics.
 6. Closer Accessories: Provide door closer accessories including custom templates, special mounting brackets, spacers and drop plates as required for proper installation. Provide through-bolt and security type fasteners as specified in the hardware sets.
- B. Door Closers, Surface Mounted (Heavy Duty): ANSI/BHMA A156.4, Grade 1 Certified Products Directory (CPD) listed surface mounted, heavy duty door closers with complete spring power adjustment, sizes 1 thru 6; and fully operational adjustable according to door size, frequency of use, and opening force. Closers to be rack and pinion type, one piece cast iron or aluminum alloy body construction, with adjustable backcheck and separate non-critical valves for closing sweep and latch speed control. Provide non-handed units standard.
1. Heavy duty surface mounted door closers shall have a 30-year warranty.
 2. Manufacturers:
 - a. Corbin Russwin Hardware (RU) - DC6000 Series.
 - b. Norton Rixson (NO) - 7500 Series.
 - c. Sargent Manufacturing (SA) - 351 Series.

2.12 SURFACE MOUNTED CLOSER HOLDERS

- A. Electromagnetic Door Holders: ANSI A156.15 electromagnetic door holder/releases with a minimum 20 to 40 pounds holding power and single coil construction able to accommodate 12VDC, 24VAC, 24VDC and 120VAC. Coils to be independently wound, employing an integral fuse and armatures to include a positive release button.
1. Manufacturers:
 - a. Norton Rixson (RF) - 980/990 Series.
 - b. Sargent Manufacturing (SA) - 1560 Series.

2.13 ARCHITECTURAL TRIM

- A. Door Protective Trim
1. General: Door protective trim units to be of type and design as specified below or in the Hardware Sets.

2. Size: Fabricate protection plates (kick, armor, or mop) not more than 2" less than door width (LDW) on stop side of single doors and 1" LDW on stop side of pairs of doors, and not more than 1" less than door width on pull side. Coordinate and provide proper width and height as required where conflicting hardware dictates. Height to be as specified in the Hardware Sets.
3. Where plates are applied to fire rated doors with the top of the plate more than 16" above the bottom of the door, provide plates complying with NFPA 80. Consult manufacturer's catalog and template book for specific requirements for size and applications.
4. Protection Plates: ANSI/BHMA A156.6 protection plates (kick, armor, or mop), fabricated from the following:
 - a. Stainless Steel: 300 grade, 050-inch thick.
5. Options and fasteners: Provide manufacturer's designated fastener type as specified in the Hardware Sets. Provide countersunk screw holes.
6. Manufacturers:
 - a. Hiawatha, Inc. (HI).
 - b. Rockwood (RO).
 - c. Trimco (TC).

2.14 DOOR STOPS AND HOLDERS

- A. General: Door stops and holders to be of type and design as specified below or in the Hardware Sets.
- B. Door Stops and Bumpers: ANSI/BHMA A156.16, Grade 1 door stops and wall bumpers. Provide wall bumpers, either convex or concave types with anchorage as indicated, unless floor or other types of door stops are specified in Hardware Sets. Do not mount floor stops where they will impede traffic. Where floor or wall bumpers are not appropriate, provide overhead type stops and holders.
 1. Manufacturers:
 - a. Hiawatha, Inc. (HI).
 - b. Rockwood (RO).
 - c. Trimco (TC).
- C. Overhead Door Stops and Holders: ANSI/BHMA A156.8, Grade 1 Certified Products Directory (CPD) listed overhead stops and holders to be surface or concealed types as indicated in Hardware Sets. Track, slide, arm and jamb bracket to be constructed of extruded bronze and shock absorber spring of heavy tempered steel. Provide non-handed design with mounting brackets as required for proper operation and function.
 1. Manufacturers:

- a. Norton Rixson (RF).
- b. Rockwood (RO).
- c. Sargent Manufacturing (SA).

2.15 ARCHITECTURAL SEALS

- A. General: Thresholds, weatherstripping, and gasket seals to be of type and design as specified below or in the Hardware Sets. Provide continuous weatherstrip gasketing on exterior doors and provide smoke, light, or sound gasketing on interior doors where indicated. At exterior applications provide non-corrosive fasteners and elsewhere where indicated.
- B. Smoke Labeled Gasketing: Assemblies complying with NFPA 105 that are listed and labeled by a testing and inspecting agency acceptable to authorities having jurisdiction, for smoke control ratings indicated, based on testing according to UL 1784.
 1. Provide smoke labeled perimeter gasketing at all smoke labeled openings.
- C. Fire Labeled Gasketing: Assemblies complying with NFPA 80 that are listed and labeled by a testing and inspecting agency acceptable to authorities having jurisdiction, for fire ratings indicated, based on testing according to UL-10C.
 1. Provide intumescent seals as indicated to meet UL10C Standard for Positive Pressure Fire Tests of Door Assemblies, and NPFA 252, Standard Methods of Fire Tests of Door Assemblies.
- D. Sound-Rated Gasketing: Assemblies that are listed and labeled by a testing and inspecting agency, for sound ratings indicated.
- E. Replaceable Seal Strips: Provide only those units where resilient or flexible seal strips are easily replaceable and readily available from stocks maintained by manufacturer.
- F. Manufacturers:
 1. Pemko (PE).

2.16 ELECTRONIC ACCESSORIES

- A. Door Position Switches: Door position magnetic reed contact switches specifically designed for use in commercial door applications. On recessed models the contact and magnetic housing snap-lock into a 1" diameter hole. Surface mounted models include wide gap distance design complete with armored flex cabling. Provide SPDT, N/O switches with optional Rare Earth Magnet installation on steel doors with flush top channels.
 1. Manufacturers:
 - a. Securitron (SU) - DPS Series.

2.17 FABRICATION

- A. Fasteners: Provide door hardware manufactured to comply with published templates generally prepared for machine, wood, and sheet metal screws. Provide screws according to manufacturers recognized installation standards for application intended.

2.18 FINISHES

- A. Standard: Designations used in the Hardware Sets and elsewhere indicate hardware finishes complying with ANSI/BHMA A156.18, including coordination with traditional U.S. finishes indicated by certain manufacturers for their products.
- B. Provide quality of finish, including thickness of plating or coating (if any), composition, hardness, and other qualities complying with manufacturer's standards, but in no case less than specified by referenced standards for the applicable units of hardware
- C. Protect mechanical finishes on exposed surfaces from damage by applying a strippable, temporary protective covering before shipping.

PART 3 - EXECUTION

3.1 EXAMINATION

- A. Examine scheduled openings, with Installer present, for compliance with requirements for installation tolerances, labeled fire door assembly construction, wall and floor construction, and other conditions affecting performance.
- B. Notify architect of any discrepancies or conflicts between the door schedule, door types, drawings and scheduled hardware. Proceed only after such discrepancies or conflicts have been resolved in writing.

3.2 PREPARATION

- A. Hollow Metal Doors and Frames: Comply with ANSI/DHI A115 series.
- B. Wood Doors: Comply with ANSI/DHI A115-W series.

3.3 INSTALLATION

- A. Install each item of mechanical and electromechanical hardware and access control equipment to comply with manufacturer's written instructions and according to specifications.
 - 1. Installers are to be trained and certified by the manufacturer on the proper installation and adjustment of fire, life safety, and security products including: hanging devices; locking devices; closing devices; and seals.

- B. Mounting Heights: Mount door hardware units at heights indicated in following applicable publications, unless specifically indicated or required to comply with governing regulations:
 - 1. Standard Steel Doors and Frames: DHI's "Recommended Locations for Architectural Hardware for Standard Steel Doors and Frames."
 - 2. DHI TDH-007-20: Installation Guide for Doors and Hardware.
 - 3. Where indicated to comply with accessibility requirements, comply with ANSI A117.1 "Accessibility Guidelines for Buildings and Facilities."
 - 4. Provide blocking in drywall partitions where wall stops or other wall mounted hardware is located.
- C. Retrofitting: Install door hardware to comply with manufacturer's published templates and written instructions. Where cutting and fitting are required to install door hardware onto or into surfaces that are later to be painted or finished in another way, coordinate removal, storage, and reinstallation of surface protective trim units with finishing work specified in Division 9 Sections. Do not install surface-mounted items until finishes have been completed on substrates involved.
- D. Thresholds: Set thresholds for exterior and acoustical doors in full bed of sealant complying with requirements specified in Division 7 Section "Joint Sealants."
- E. Storage: Provide a secure lock up for hardware delivered to the project but not yet installed. Control the handling and installation of hardware items so that the completion of the work will not be delayed by hardware losses before and after installation.

3.4 FIELD QUALITY CONTROL

- A. Field Inspection (Punch Report): Reference Division 01 Sections "Closeout Procedures". Produce project punch report for each installed door opening indicating compliance with approved submittals and verification hardware is properly installed, operating and adjusted. Include list of items to be completed and corrected, indicating the reasons or deficiencies causing the Work to be incomplete or rejected.
 - 1. Organization of List: Include separate Door Opening and Deficiencies and Corrective Action Lists organized by Mark, Opening Remarks and Comments, and related Opening Images and Video Recordings.

3.5 ADJUSTING

- A. Initial Adjustment: Adjust and check each operating item of door hardware and each door to ensure proper operation or function of every unit. Replace units that cannot be adjusted to operate as intended. Adjust door control devices to compensate for final operation of heating and ventilating equipment and to comply with referenced accessibility requirements.

3.6 CLEANING AND PROTECTION

- A. Protect all hardware stored on construction site in a covered and dry place. Protect exposed hardware installed on doors during the construction phase. Install any and all hardware at the latest possible time frame.
- B. Clean adjacent surfaces soiled by door hardware installation.
- C. Clean operating items as necessary to restore proper finish. Provide final protection and maintain conditions that ensure door hardware is without damage or deterioration at time of owner occupancy.

3.7 DEMONSTRATION

- A. Instruct Owner's maintenance personnel to adjust, operate, and maintain mechanical and electromechanical door hardware.

3.8 DOOR HARDWARE SETS

- A. The hardware sets represent the design intent and direction of the owner and architect. They are a guideline only and should not be considered a detailed hardware schedule. Discrepancies, conflicting hardware and missing items should be brought to the attention of the architect with corrections made prior to the bidding process. Omitted items not included in a hardware set should be scheduled with the appropriate additional hardware required for proper application and functionality.
 - 1. Quantities listed are for each pair of doors, or for each single door.
 - 2. The supplier is responsible for handing and sizing all products.
 - 3. Where multiple options for a piece of hardware are given in a single line item, the supplier shall provide the appropriate application for the opening.
 - 4. At existing openings with new hardware the supplier shall field inspect existing conditions prior to the submittal stage to verify the specified hardware will work as required. Provide alternate solutions and proposals as needed.
- B. Manufacturer's Abbreviations:
- C. Refer to Section 080671, Door Hardware Sets, for hardware sets.

- 1. MK - McKinney
- 2. PE - Pemko
- 3. SU - Securitron
- 4. RO - Rockwood
- 5. SA - SARGENT

- 6. AD - Adams Rite
- 7. OT - Other
- 8. HS - HES
- 9. FO - Folger Adam
- 10. GS - ASSA ABLOY Glass Solutions
- 11. NO - Norton
- 12. RF - Rixson

Hardware Sets

Set: 1.0

Doors: 100, 101, 113, 124, 143

1 ElectroLynx Adaptor	2004M		HS	↗
1 SMART Pac Bridge Rectifier	2005M3		HS	↗
1 Electric Strike (Pair)	310-4-X as req'd	630	FO	↗
2 Frame Harness	QC-C1500P (as required)		MK	↗
1 Card Reader	Provided by access control		OT	

Notes: Verify hardware compatibility with existing conditions.

Set: 2.0

Description: NOT USED

Set: 3.0

Doors: 182, 189, 190, 201

6 Hinge, Full Mortise, Hvy Wt	T4A3386	US32D	MK	
1 Surface Vert Rod Exit, Exit Only	NB8710 EO	US32D	SA	
1 Surface Vert Rod Exit	NB8710 306 x Less Pull	US32D	SA	
1 Cylinder & Core	BEST CorMax or as req'd		OT	
1 ElectroLynx Adaptor	2004M		HS	↗
1 SMART Pac Bridge Rectifier	2005M3		HS	↗
1 Electric Strike (Single)	310-4-X as req'd	630	FO	↗
2 Pull	RM3131-36	US32D	RO	
2 Surface Closer (Stop Arm)	351 CPS	EN	SA	
1 Threshold	Per sill detail		PE	
1 Gasketing	S773BL		PE	
1 Rain Guard	346C		PE	
2 Sweep	315CN		PE	
1 Frame Harness	QC-C1500P (as required)		MK	↗
1 Card Reader	Provided by access control		OT	

JEROME JOINT SCHOOL DISTRICT 261 JEFFERSON ELEMENTARY (K-6) ADDRENOV
 JEROME, ID

Set: 4.0

Doors: 183

6 Hinge, Full Mortise, Hvy Wt	T4A3386	US32D	MK
2 Dummy Bar	8893	US32D	SA
2 Pull	RM3131-36	US32D	RO
2 Surface Closer	351 O/P10 (type as required)	EN	SA
1 Door Stop	406/409/441H (type as required)	US32D	RO
1 Gasketing / Seals	By door manufacturer		OT

Set: 4.0 ALT

Doors: 142, 195

6 Hinge, Full Mortise, Hvy Wt	T4A3386	US32D	MK
2 Dummy Bar	8893	US32D	SA
2 Pull	RM3131-36	US32D	RO
2 Surface Closer	351 O/P10 (type as required)	EN	SA
2 Door Stop	406/409/441H (type as required)	US32D	RO
1 Gasketing / Seals	By door manufacturer		OT

Set: 5.0

Doors: 180b

3 Hinge, Full Mortise, Hvy Wt	T4A3386	US32D	MK
1 Rim Exit Device, Storeroom	8804 ETP	US32D	SA
1 Cylinder & Core	BEST CorMax or as req'd		OT
1 Surface Closer	351 O/P10 (type as required)	EN	SA
1 Kick Plate	K1050 10" CSK BEV	US32D	RO
1 Door Stop	466-RKW	Black	RO
1 Threshold	Per sill detail		PE
1 Gasketing	S773BL		PE
1 Rain Guard	346C		PE
1 Sweep	315CN		PE
1 Position Switch	DPS-M/W-BK		SU ↵

Set: 7.0

Doors: 181, 184a, 184b

6 Hinge, Full Mortise, Hvy Wt	T4A3786	US26D	MK
1 Surface Vert Rod Exit	NB8710 ETP	US32D	SA
1 Surface Vert Rod Exit, Classroom	NB8713 ETP	US32D	SA
1 Cylinder & Core	BEST CorMax or as req'd		OT
2 Surface Closer	351 O/P10 (type as required)	EN	SA
2 Kick Plate	K1050 10" CSK BEV	US32D	RO

JEROME JOINT SCHOOL DISTRICT 261 JEFFERSON ELEMENTARY (K-6) ADDRENOV
 JEROME, ID

2 Door Stop	406/409/441H (type as required)	US32D	RO
1 Gasketing	S88BL		PE

Set: 7.0 ALT

Doors: 148a

6 Hinge, Full Mortise, Hvy Wt	T4A3786	US26D	MK
1 Surface Vert Rod Exit	NB8710 ETP	US32D	SA
1 Surface Vert Rod Exit, Classroom	NB8713 ETP	US32D	SA
1 Cylinder & Core	BEST CorMax or as req'd		OT
2 Surface Closer	351 O/P10 (type as required)	EN	SA
2 Kick Plate	K1050 10" CSK BEV	US32D	RO
2 Door Stop	406/409/441H (type as required)	US32D	RO
1 Gasketing	S88BL		PE

Set: 8.0

Doors: 163c

3 Hinge, Full Mortise, Hvy Wt	T4A3786	US26D	MK
1 Dummy Bar	8893	US32D	SA
1 Surface Closer	351 O/P10 (type as required)	EN	SA
1 Kick Plate	K1050 10" CSK BEV	US32D	RO
1 Door Stop	406/409/441H (type as required)	US32D	RO
1 Gasketing	S88BL		PE

Set: 9.0

Doors: 184c, 186a, 186b

3 Hinge, Full Mortise, Hvy Wt	T4A3786	US26D	MK
1 Rim Exit Device, Classroom	12 8813 ETP	US32D	SA
1 Cylinder & Core	BEST CorMax or as req'd		OT
1 Surface Closer	351 O/P10 (type as required)	EN	SA
1 Kick Plate	K1050 10" CSK BEV	US32D	RO
1 Door Stop	406/409/441H (type as required)	US32D	RO
1 Gasketing	S88BL		PE

Set: 10.0

Doors: 185, 188

6 Hinge, Full Mortise	TA2714	US26D	MK
1 Flush Bolt	555	US26D	RO
1 Storeroom/Closet Lock	10XG04 LP	US26D	SA
1 Cylinder & Core	BEST CorMax or as req'd		OT
2 Door Stop	406/409/441H (type as required)	US32D	RO

JEROME JOINT SCHOOL DISTRICT 261 JEFFERSON ELEMENTARY (K-6) ADDRENOV
 JEROME, ID

1 Gasketing S88BL PE

Set: 11.0

Doors: 145b, 149, 150, 151, 154, 165, 180a, 187

3 Hinge, Full Mortise	TA2714	US26D	MK
1 Storeroom/Closet Lock	10XG04 LP	US26D	SA
1 Cylinder & Core	BEST CorMax or as req'd		OT
1 Surface Closer	351 O/P10 (type as required)	EN	SA
1 Kick Plate	K1050 10" CSK BEV	US32D	RO
1 Door Stop	406/409/441H (type as required)	US32D	RO
1 Gasketing	S88BL		PE

Set: 11.0 ALT

Doors: 140

3 Hinge, Full Mortise	TA2714	US26D	MK
1 Storeroom/Closet Lock	10XG04 LP	US26D	SA
1 Cylinder & Core	BEST CorMax or as req'd		OT
1 Surface Closer	351 O/P10 (type as required)	EN	SA
1 Kick Plate	K1050 10" CSK BEV	US32D	RO
1 Door Stop	406/409/441H (type as required)	US32D	RO
1 Gasketing	S88BL		PE

Set: 12.0

Doors: 176

3 Hinge, Full Mortise	TA2714	US26D	MK
1 Storeroom/Closet Lock	10XG04 LP	US26D	SA
1 Cylinder & Core	BEST CorMax or as req'd		OT
1 Concealed Overhead Stop	698S	EN	SA
1 Surface Closer	351 O/P10 (type as required)	EN	SA
1 Kick Plate	K1050 10" CSK BEV	US32D	RO
1 Gasketing	S88BL		PE

Set: 13.0

Doors: 114, 146

3 Hinge, Full Mortise	TA2714	US26D	MK
1 Storeroom/Closet Lock	10XG04 LP	US26D	SA
1 Cylinder & Core	BEST CorMax or as req'd		OT
1 Door Stop	406/409/441H (type as required)	US32D	RO

Set: 14.0

JEROME JOINT SCHOOL DISTRICT 261 JEFFERSON ELEMENTARY (K-6) ADDRENOV
 JEROME, ID

Doors: 164, 184d

3 Hinge, Full Mortise, Hvy Wt	T4A3386	US32D	MK
1 Rim Exit Device, Storeroom	8804 ETP	US32D	SA
1 ElectroLynx Adaptor	2004M		HS ↗
1 SMART Pac Bridge Rectifier	2005M3		HS ↗
1 Electric Strike	9500	630	HS ↗
1 Surface Closer (Stop Arm)	351 CPS	EN	SA
1 Kick Plate	K1050 10" CSK BEV	US32D	RO
1 Threshold	Per sill detail		PE
1 Gasketing	S773BL		PE
1 Rain Guard	346C		PE
1 Sweep	315CN		PE
1 Frame Harness	QC-C1500P (as required)		MK ↗
1 Position Switch	DPS-M/W-BK		SU ↗

Set: 15.0

Doors: 152b

3 Hinge, Full Mortise, Hvy Wt	T4A3386	US32D	MK
1 Rim Exit Device, Storeroom	8804 ETP	US32D	SA
1 ElectroLynx Adaptor	2004M		HS ↗
1 SMART Pac Bridge Rectifier	2005M3		HS ↗
1 Electric Strike	9500	630	HS ↗
1 Surface Closer (Stop Arm)	351 CPS	EN	SA
1 Kick Plate	K1050 10" CSK BEV	US32D	RO
1 Threshold	Per sill detail		PE
1 Gasketing	S773BL		PE
1 Rain Guard	346C		PE
1 Sweep	315CN		PE
1 Frame Harness	QC-C1500P (as required)		MK ↗
1 Position Switch	DPS-M/W-BK		SU ↗
1 Viewer	626	DCRM	RO
1 Card Reader	Provided by access control		OT

Notes: Doorbell on exterior by electrical provider.

Set: 17.0

Doors: 120b, 159a, 171b, 172b, 173b, 174b

3 Hinge, Full Mortise	TA2714	US26D	MK
1 Entry/Office Lock	10XG05 LP	US26D	SA
1 Cylinder & Core	BEST CorMax or as req'd		OT
1 Door Stop	406/409/441H (type as required)	US32D	RO

JEROME JOINT SCHOOL DISTRICT 261 JEFFERSON ELEMENTARY (K-6) ADDRENOV
 JEROME, ID

Set: 17.0 ALT

Doors: 132, 160

3 Hinge, Full Mortise	TA2714	US26D	MK
1 Entry/Office Lock	10XG05 LP	US26D	SA
1 Cylinder & Core	BEST CorMax or as req'd		OT
1 Door Stop	406/409/441H (type as required)	US32D	RO

Set: 18.0

Doors: 145a, 152a, 152c

3 Hinge, Full Mortise	TA2714	US26D	MK
1 Entry/Office Lock	10XG05 LP	US26D	SA
1 Cylinder & Core	BEST CorMax or as req'd		OT
1 Surface Closer	351 O/P10 (type as required)	EN	SA
1 Kick Plate	K1050 10" CSK BEV	US32D	RO
1 Door Stop	406/409/441H (type as required)	US32D	RO
1 Gasketing	S88BL		PE

Set: 19.0

Doors: 120a, 147

3 Hinge, Full Mortise	TA2714	US26D	MK
1 Classroom Security Lock	10XG38 LP	US26D	SA
1 Cylinder & Core	BEST CorMax or as req'd		OT
1 Door Stop	406/409/441H (type as required)	US32D	RO
1 Gasketing	S88BL		PE

Set: 19.0 ALT

Doors: 157, 172a, 174a, 196a, 197a, 198a, 199a, 200a

3 Hinge, Full Mortise	TA2714	US26D	MK
1 Classroom Security Lock	10XG38 LP	US26D	SA
1 Cylinder & Core	BEST CorMax or as req'd		OT
1 Door Stop	406/409/441H (type as required)	US32D	RO
1 Gasketing	S88BL		PE

Set: 19.1 ALT

Doors: 133, 134, 135, 136, 167, 169, 170, 171a, 173a

3 Hinge, Full Mortise	TA2714	US26D	MK
1 Classroom Security Lock	10XG38 LP	US26D	SA
1 Cylinder & Core	BEST CorMax or as req'd		OT

JEROME JOINT SCHOOL DISTRICT 261 JEFFERSON ELEMENTARY (K-6) ADDRENOV
 JEROME, ID

1 Concealed Overhead Stop	698S	EN	SA
1 Gasketing	S88BL		PE

Set: 20.0

Doors: 137, 168

1 Classroom Security Lock	10XG38 LP	US26D	SA
1 Cylinder & Core	BEST CorMax or as req'd		OT

Set: 20.0 ALT

Doors: 175

3 Hinge, Full Mortise	TA2714	US26D	MK
1 Classroom Security Lock	10XG38 LP	US26D	SA
1 Cylinder & Core	BEST CorMax or as req'd		OT
1 Surface Closer	351 O/P10 (type as required)	EN	SA
1 Kick Plate	K1050 10" CSK BEV	US32D	RO
1 Door Stop	406/409/441H (type as required)	US32D	RO
1 Gasketing	S88BL		PE

Set: 21.0

Doors: 191, 192

3 Hinge, Full Mortise	TA2714	US26D	MK
1 Privacy Lock w/Occ. Ind.	V21 8266 LNP	US26D	SA
1 Surface Closer	351 O/P10 (type as required)	EN	SA
1 Kick Plate	K1050 10" CSK BEV	US32D	RO
1 Door Stop	406/409/441H (type as required)	US32D	RO
1 Gasketing	S88BL		PE

Set: 23.0

Doors: 144, 177, 178, 196b, 197b, 198b, 199b, 200b

1 Privacy Lock w/Occ. Ind.	V21 8266 LNP	US26D	SA
----------------------------	--------------	-------	----

Set: 24.0

3 Hinge, Full Mortise	TA2714	US26D	MK
1 Passage Latch	10XU15 LP	US26D	SA
1 Surface Closer	351 O/P10 (type as required)	EN	SA
1 Kick Plate	K1050 10" CSK BEV	US32D	RO
1 Door Stop	406/409/441H (type as required)	US32D	RO
1 Gasketing	S88BL		PE

JEROME JOINT SCHOOL DISTRICT 261 JEFFERSON ELEMENTARY (K-6) ADDRENOV
JEROME, ID

Set: 26.0

Doors: 193, 194

3 Hinge, Full Mortise	TA2714	US26D	MK
1 Pull Plate	110x70C	US32D	RO
1 Push Plate	70C-RKW	US32D	RO
1 Surface Closer (Hold Open)	351 H / PH	EN	SA
1 Kick Plate	K1050 10" CSK BEV	US32D	RO
1 Door Stop	406/409/441H (type as required)	US32D	RO
1 Gasketing	S88BL		PE

Set: 26.0 ALT

Doors: 141

3 Hinge, Full Mortise	TA2714	US26D	MK
1 Pull Plate	110x70C	US32D	RO
1 Push Plate	70C-RKW	US32D	RO
1 Surface Closer (Hold Open)	351 H / PH	EN	SA
1 Kick Plate	K1050 10" CSK BEV	US32D	RO
1 Door Stop	406/409/441H (type as required)	US32D	RO
1 Gasketing	S88BL		PE

END OF SECTION 087100

SECTION 088000 – GLAZING

PART 1 - GENERAL

1.1 RELATED DOCUMENTS

- A. Drawings and general provisions of the Contract, including General and Supplementary Conditions and Division 01 Specification Sections, apply to this Section.

1.2 SUMMARY

- A. This Section includes glazing for the following products and applications, including those specified in other Sections where glazing requirements are specified by reference to this Section:
 - 1. Windows.
 - 2. Doors.
 - 3. Sidelights.
 - 4. Interior borrow lites.

1.3 DEFINITIONS

- A. Manufacturers of Glass Products: Firms that produce primary glass, fabricated glass, or both, as defined in referenced glazing publications.
- B. Glass Thicknesses: Indicated by thickness designations in millimeters according to ASTM C 1036.
- C. Interspace: Space between lites of an insulating-glass unit that contains dehydrated air or a specified gas.
- D. Deterioration of Coated Glass: Defects developed from normal use that are attributed to the manufacturing process and not to causes other than glass breakage and practices for maintaining and cleaning coated glass contrary to manufacturer's written instructions. Defects include peeling, cracking, and other indications of deterioration in metallic coating.
- E. Deterioration of Insulating Glass: Failure of hermetic seal under normal use that is attributed to the manufacturing process and not to causes other than glass breakage and practices for maintaining and cleaning insulating glass contrary to manufacturer's written instructions. Evidence of failure is the obstruction of vision by dust, moisture, or film on interior surfaces of glass.

1.4 PERFORMANCE REQUIREMENTS

- A. Thermal Movements: Provide glazing that allows for thermal movements resulting from the following maximum change (range) in ambient and surface temperatures acting on glass framing

members and glazing components. Base engineering calculation on surface temperatures of materials due to both solar heat gain and nighttime-sky heat loss.

1. Temperature Change (Range): 120 deg F (67 deg C), ambient; 180 deg F (100 deg C), material surfaces.
- B. Thermal and Optical Performance Properties: Provide glass with performance properties specified based on manufacturer's published test data, as determined according to procedures indicated below:
1. For monolithic-glass lites, properties are based on units with lites 6.0 mm thick.
 2. For insulating-glass units, properties are based on units of thickness indicated for overall unit and for each lite.

1.5 SUBMITTALS

- A. Product Data: For each glass product and glazing material indicated. IBC required test results for safety glazing.
- B. Samples: For the following products, in the form of 12-inch- (300-mm-) square Samples for glass.
1. Each color of tinted float glass.
 2. Wired glass.
 3. Insulating glass for each designation indicated.
 4. For each color (except black) of exposed glazing sealant indicated.
- C. Product Certificates: Signed by manufacturers of glass and glazing products certifying that products furnished comply with requirements.
1. For solar-control low-e-coated glass, provide documentation demonstrating that manufacturer of coated glass is certified by coating manufacturer.
- D. Qualification Data: For installers.
- E. Warranties: Special warranties specified in this Section.

1.6 QUALITY ASSURANCE

- A. Installer Qualifications: An experienced installer who has completed glazing similar in material, design, and extent to that indicated for this Project; whose work has resulted in glass installations with a record of successful in-service performance.
- B. Source Limitations for Glass: Obtain the following through one source from a single manufacturer for each glass type: clear float glass, tinted.
- C. Source Limitations for Glass Sputter-Coated with Solar-Control Low-E Coatings: Where solar-control low-e coatings of a primary glass manufacturer that has established a certified fabricator program is specified, obtain sputter-coated solar-control low-e-coated glass in fabricated units from a manufacturer that is certified by coated-glass manufacturer.

- D. Source Limitations for Glazing Accessories: Obtain glazing accessories through one source from a single manufacturer for each product and installation method indicated.
- E. Safety Glazing Products: Comply with testing requirements in 16 CFR 1201 and ANSI Z97.1. Comply with IBC Sections 2406.1 and 2406.2.
 - 1. Subject to compliance with requirements, obtain safety glazing products permanently marked with certification label of the Safety Glazing Certification Council or another certification agency or manufacturer acceptable to authorities having jurisdiction.
 - 2. Where glazing units, including Kind FT glass are specified in Part 2 articles for glazing lites more than 9 sq. ft. (0.84 sq. m) in exposed surface area of one side, provide glazing products that comply with Category II materials, for lites 9 sq. ft. (0.84 sq. m) or less in exposed surface area of one side, provide glazing products that comply with Category I or II materials, except for hazardous locations where Category II materials are required by 16 CFR 1201 and regulations of authorities having jurisdiction.
- F. Glazing Publications: Comply with published recommendations of glass product manufacturers and organizations below, unless more stringent requirements are indicated. Refer to these publications for glazing terms not otherwise defined in this Section or in referenced standards.
 - 1. Glass Association of North America (GANA) Publications: GANA's "Glazing Manual."
 - 2. Insulating Glass Manufacturers Alliance (IGMA) Publication for Insulating Glass: SIGMA TM-3000, "Glazing Guidelines for Sealed Insulating Glass Units."
- G. Insulating-Glass Certification Program: Permanently marked either on spacers or on at least one component lite of units with appropriate certification label of the following testing and inspecting agency:
 - 1. Insulating Glass Certification Council.
 - 2. Associated Laboratories, Inc.

1.7 DELIVERY, STORAGE, AND HANDLING

- A. Protect glazing materials according to manufacturer's written instructions and as needed to prevent damage to glass and glazing materials from condensation, temperature changes, direct exposure to sun, or other causes.
- B. For insulating-glass units that will be exposed to substantial altitude changes, comply with insulating-glass manufacturer's written recommendations for venting and sealing to avoid hermetic seal ruptures.

1.8 PROJECT CONDITIONS

- A. Environmental Limitations: Do not proceed with glazing when ambient and substrate temperature conditions are outside limits permitted by glazing material manufacturers and when glazing channel substrates are wet from rain, frost, condensation, or other causes.

1. Do not install liquid glazing sealants when ambient and substrate temperature conditions are outside limits permitted by glazing sealant manufacturer or below 40 deg F (4.4 deg C).

1.9 WARRANTY

- A. Manufacturer's Special Warranty for Coated-Glass Products: Manufacturer's standard form, made out to Owner and signed by coated-glass manufacturer agreeing to replace coated-glass units that deteriorate as defined in "Definitions" Article, f.o.b. the nearest shipping point to Project site, within specified warranty period indicated below.

1. Warranty Period: 10 years from date of Substantial Completion.

- B. Manufacturer's Special Warranty on Insulating Glass: Manufacturer's standard form, made out to Owner and signed by insulating-glass manufacturer agreeing to replace insulating-glass units that deteriorate as defined in "Definitions" Article, f.o.b. the nearest shipping point to Project site, within specified warranty period indicated below.

1. Warranty Period: 10 years from date of Substantial Completion.

PART 2 - PRODUCTS

2.1 MANUFACTURERS

- A. In other Part 2 articles where titles below introduce lists, the following requirements apply to product selection:

1. Manufacturers / Products: Subject to compliance with requirements, provide one of the manufacturers / products specified.
2. Products by other manufacturers are subject to Architect's approval prior to bidding.

2.2 GLASS PRODUCTS

- A. Annealed Float Glass: ASTM C 1036, Type I (transparent flat glass), Quality-Q3; of class indicated.

- B. Heat-Treated Float Glass: ASTM C 1048; Type I (transparent flat glass); Quality-Q3; of class, kind, and condition indicated.

1. Fabrication Process: By horizontal (roller-hearth) process with roll-wave distortion parallel to bottom edge of glass as installed, unless otherwise indicated.
2. Provide Kind HS (heat-strengthened) float glass in place of annealed float glass where needed to resist thermal stresses induced by differential shading of individual glass lites.
3. For uncoated glass, comply with requirements for Condition A.
4. For coated vision glass, comply with requirements for Condition C (other uncoated glass).
5. Provide Kind FT (fully tempered) float glass where safety glass is indicated.

- C. Sputter-Coated Float Glass: ASTM C 1376, float glass with metallic-oxide or -nitride coating deposited by vacuum deposition process after manufacture and heat treatment (if any), and complying with other requirements specified.
- D. Insulating-Glass Units, General: Factory-assembled units consisting of sealed lites of glass separated by a dehydrated interspace, and complying with ASTM E 774 for Class CBA units and with requirements specified in this Article and in Part 2 "Insulating-Glass Units" Article.
 - 1. Provide Kind HS (heat-strengthened) float glass in place of annealed glass where needed to resist thermal stresses induced by differential shading of individual glass lites.
 - 2. Provide Kind FT (fully tempered) glass lites where safety glass is indicated.
 - 3. Overall Unit Thickness and Thickness of Each Lite: Dimensions indicated for insulating-glass units are nominal and the overall thicknesses of units are measured perpendicularly from outer surfaces of glass lites at unit's edge.
 - 4. Sealing System: Dual seal, with primary and secondary sealants as follows:
 - a. Manufacturer's standard sealants.
 - 5. Spacer Specifications: Manufacturer's standard spacer material and construction.
 - b. Desiccant: Molecular sieve or silica gel, or blend of both.
 - c. Corner Construction: Manufacturer's standard corner construction.

2.3 GLAZING GASKETS

- A. Glazing gaskets for aluminum framed entrances and store fronts are provided by such aluminum items manufacturer.

2.4 GLAZING SEALANTS

- A. General: Provide products of type indicated, complying with the following requirements:
 - 1. Compatibility: Select glazing sealants that are compatible with one another and with other materials they will contact, including glass products and glazing tapes under conditions of service and application.
 - 2. Colors of Exposed Glazing Sealants: As selected by Architect from manufacturer's full range.
- B. Elastomeric Glazing Sealants: Comply with ASTM C 920 and other requirements indicated for each liquid-applied chemically curing sealant specified, including those referencing ASTM C 920 classifications for type, grade, class, and uses related to exposure and joint substrates.
 - 1. Single-Component Silicone Glazing Sealants:
 - a. Products:
 - 1) Dow Corning Corporation; 790.

- 2) GE Silicones; SilPruf LM SCS2700.
- 3) Tremco; Spectrem 1 (Basic).
- 4) Sonneborn, Div. of ChemRex, Inc.; Omniseal.

- b. Type and Grade: S (single component) and NS (nonsag).
- c. Use Related to Exposure: NT (nontraffic).

2.5 GLAZING TAPES

- A. Expanded Cellular Glazing Tapes: Closed-cell, PVC foam tapes; factory coated with adhesive on both surfaces; packaged on rolls with release liner protecting adhesive; and complying with American Architectural Manufacturers Association (AAMA) AAMA 800 for the following types:
 1. Type 2, for glazing applications in which tape is used in combination with a full bead of liquid sealant.

2.6 MISCELLANEOUS GLAZING MATERIALS

- A. General: Provide products of material, size, and shape complying with referenced glazing standard, requirements of manufacturers of glass and other glazing materials for application indicated, and with a proven record of compatibility with surfaces contacted in installation.
- B. Cleaners, Primers, and Sealers: Types recommended by sealant or gasket manufacturer.
- C. Setting Blocks: Elastomeric material with a Shore, Type A durometer hardness of 85, plus or minus 5.
- D. Spacers: Elastomeric blocks or continuous extrusions with a Shore, Type A durometer hardness required by glass manufacturer to maintain glass lites in place for installation indicated.
- E. Edge Blocks: Elastomeric material of hardness needed to limit glass lateral movement (side walking).
- F. Cylindrical Glazing Sealant Backing: ASTM C 1330, Type O (open-cell material), of size and density to control glazing sealant depth and otherwise produce optimum glazing sealant performance.

2.7 FABRICATION OF GLAZING UNITS

- A. Fabricate glazing units in sizes required to glaze openings indicated for Project, with edge and face clearances, edge and surface conditions, and bite complying with written instructions of product manufacturer and referenced glazing publications, to comply with system performance requirements.
- B. Clean-cut or flat-grind vertical edges of butt-glazed monolithic lites in a manner that produces square edges with slight kerfs at junctions with outdoor and indoor faces.
- C. Grind smooth and polish exposed glass edges and corners.

2.8 MONOLITHIC FLOAT-GLASS UNITS

- A. Uncoated Clear Float-Glass Units: Class 1 (clear) float glass annealed or Kind HS (heat-strengthened) float glass where heat strengthening is required to resist thermal stresses induced by differential shading of individual glass lites, and Kind FT (fully tempered) float glass where safety glass is indicated.
1. Manufacturer / Product:
 - a. Vitro Architectural Glass
 2. Thickness: 1/4".
- B. Uncoated Tinted Float-Glass Units: Class 2 (tinted) annealed float glass or Kind HS (heat-strengthened) float glass, where heat strengthening is required to resist thermal stresses induced by differential shading of individual glass lites, and Kind FT (fully tempered) float glass.
1. Manufacturer / Product:
 - a. Vitro Architectural Glass / Solarban 60 Solar Control Low E glass.
 2. Thickness: 1/4".

2.9 INSULATING-GLASS UNITS

- A. Low E Insulating-Glass Units:
1. Manufacturer / Product:
 - a. Vitro Architectural Glass / Optigray + Solarban 60 (3) clear.
 2. Overall Unit Thickness and Thickness of Each Lite: 1" overall with 1/4" lites.
 3. Interspace Content: Air.
 4. Outdoor Lite: Class 2 (tinted) float glass.
 - a. Tint Color: Gray
 - b. Annealed, Kind HS (heat strengthened) or Kind FT (fully tempered) where required.
 5. Indoor Lite: Class 1 (clear) float glass.
 - a. Annealed, Kind HS (heat strengthened) or Kind FT (fully tempered) where required.
 6. Low-E Coating: Sputtered on third surface.
 7. Visible Light Transmittance: 50 percent minimum.
 8. Winter Nighttime U-Factor: .29 maximum.
 9. Light to Solar Gain: 1.43 maximum.
 10. Solar Heat Gain Coefficient: .35 maximum.

PART 3 - EXECUTION

3.1 EXAMINATION

- A. Examine framing glazing, with Installer present, for compliance with the following:
 - 1. Manufacturing and installation tolerances, including those for size, squareness, and offsets at corners.
 - 2. Presence and functioning of weep system.
 - 3. Minimum required face or edge clearances.
 - 4. Effective sealing between joints of glass-framing members.
- B. Proceed with installation only after unsatisfactory conditions have been corrected.

3.2 PREPARATION

- A. Clean glazing channels and other framing members receiving glass immediately before glazing. Remove coatings not firmly bonded to substrates.

3.3 GLAZING, GENERAL

- A. Comply with combined written instructions of manufacturers of glass, sealants, gaskets, and other glazing materials, unless more stringent requirements are indicated, including those in referenced glazing publications.
- B. Protect glass edges from damage during handling and installation. Remove damaged glass from Project site and legally dispose of off Project site. Damaged glass is glass with edge damage or other imperfections that, when installed, could weaken glass and impair performance and appearance.
- C. Apply primers to joint surfaces where required for adhesion of sealants or glazing tapes.
- D. Install setting blocks in sill rabbets, sized and located to comply with referenced glazing publications, unless otherwise required by glass manufacturer. Set blocks in thin course of compatible sealant suitable for heel bead.
- E. Do not exceed edge pressures stipulated by glass manufacturers for installing glass lites.
- F. Provide spacers for glass lites where length plus width is larger than 50 inches (1270 mm) as follows:
 - 1. Locate spacers directly opposite each other on both inside and outside faces of glass. Install correct size and spacing to preserve required face clearances, unless gaskets and glazing tapes are used that have demonstrated ability to maintain required face clearances and to comply with system performance requirements.

2. Provide 1/8-inch (3-mm) minimum bite of spacers on glass and use thickness equal to sealant width. With glazing tape, use thickness slightly less than final compressed thickness of tape.
- G. Provide edge blocking where indicated or needed to prevent glass lites from moving sideways in glazing channel, as recommended in writing by glass manufacturer and according to requirements in referenced glazing publications.
- H. Set glass lites in each series with uniform pattern, draw, bow, and similar characteristics.

3.4 TAPE GLAZING

- A. Position tapes on fixed stops so that, when compressed by glass, their exposed edges are flush with or protrude slightly above sightline of stops.
- B. Install tapes continuously, but not necessarily in one continuous length. Do not stretch tapes to make them fit opening.
- C. Cover vertical framing joints by applying tapes to heads and sills first and then to jambs. Cover horizontal framing joints by applying tapes to jambs and then to heads and sills.
- D. Place joints in tapes at corners of opening with adjoining lengths butted together, not lapped. Seal joints in tapes with compatible sealant approved by tape manufacturer.
- E. Do not remove release paper from tape until just before each glazing unit is installed.
- F. Apply heel bead of elastomeric sealant.
- G. Center glass lites in openings on setting blocks and press firmly against tape by inserting dense compression gaskets formed and installed to lock in place against faces of removable stops. Start gasket applications at corners and work toward centers of openings.
- H. Apply cap bead of elastomeric sealant over exposed edge of tape.

3.5 GASKET GLAZING (DRY)

- A. Glaze openings in aluminum framed entrances and storefronts in accordance with instructions of manufacturer of such aluminum items.

3.6 CLEANING AND PROTECTION

- A. Protect exterior glass from damage immediately after installation by attaching crossed streamers to framing held away from glass. Do not apply markers to glass surface. Remove nonpermanent labels, and clean surfaces.
- B. Protect glass from contact with contaminating substances resulting from construction operations, including weld splatter. If, despite such protection, contaminating substances do come into contact with glass, remove substances immediately as recommended by glass manufacturer.

- C. Examine glass surfaces adjacent to or below exterior concrete and other masonry surfaces at frequent intervals during construction, but not less than once a month, for buildup of dirt, scum, alkaline deposits, or stains; remove as recommended in writing by glass manufacturer.
- D. Remove and replace glass that is broken, chipped, cracked, or abraded or that is damaged from natural causes, accidents, and vandalism, during construction period.
- E. Wash glass on both exposed surfaces in each area of Project not more than four days before date scheduled for inspections that establish date of Substantial Completion. Wash glass as recommended in writing by glass manufacturer.

END OF SECTION 088000

SECTION 092400 - PORTLAND CEMENT PLASTER

PART 1 - GENERAL

1.1 RELATED DOCUMENTS

- A. Drawings and general provisions of the Contract, including General and Supplementary Conditions and Division 1 Specification Sections, apply to this Section.

1.2 SUMMARY

- A. This Section includes the following:
 - 1. Exterior portland cement plasterwork (stucco) on metal lath.

1.3 SUBMITTALS

- A. Product Data: For each type of product indicated.
- B. Samples for Selection: For each type of factory-prepared finish coat indicated, provide complete range of colors and textures available for color selection and texture selection by the Architect.

1.4 QUALITY ASSURANCE

- A. Fire-Test-Response Characteristics: For portland cement plaster assemblies with fire-resistance ratings, provide materials and construction identical to those tested in assembly indicated according to ASTM E 119 by an independent testing and inspecting agency acceptable to authorities having jurisdiction.
- B. Mockups: Before plastering, install mockups of at least 16 sq. ft. in surface area to demonstrate aesthetic effects and set quality standards for materials and execution.
 - 1. Install mockups for each type of finish indicated.

1.5 DELIVERY, STORAGE, AND HANDLING

- A. Store materials inside under cover and keep them dry and protected against damage from weather, direct sunlight, surface contamination, corrosion, construction traffic, and other causes.

1.6 PROJECT CONDITIONS

- A. Comply with ASTM C 926 requirements.

- B. Exterior Plasterwork:
 - 1. Apply and cure plaster to prevent plaster drying out during curing period. Use procedures required by climatic conditions, including moist curing, providing coverings, and providing barriers to deflect sunlight and wind.
 - 2. Apply plaster when ambient temperature is greater than 40 deg F.
 - 3. Protect plaster coats from freezing for not less than 48 hours after set of plaster coat has occurred.
- C. Factory-Prepared Finishes: Comply with manufacturer's written recommendations for environmental conditions for applying finishes.

PART 2 - PRODUCTS

2.1 MANUFACTURERS

- A. In other Part 2 articles where titles below introduce lists, the following requirements apply to product selection:
 - 1. Products: Subject to compliance with requirements, provide one of the products specified.
 - 2. Equal products by other manufacturers are subject to approval prior to bidding.

2.2 METAL LATH

- A. Expanded-Metal Lath: ASTM C 847 with ASTM A 653/A 653M, G60, hot-dip galvanized zinc coating.
 - 1. Manufacturers:
 - a. Alabama Metal Industries Corporation (AMICO).
 - b. California Expanded Metal Products Company (CEMCO).
 - c. Dale/Incor.
 - d. Marino/Ware; Division of Ware Industries, Inc.
 - e. Phillips Manufacturing Co.
 - f. Unimast, Inc.
 - g. Western Metal Lath & Steel Framing Systems.
 - 2. Diamond-Mesh Lath: Self-furring.
 - a. Weight: 3.4 lb/sq. yd.
 - 3. 3/8 Diamond – Mesh Rib Lath.
 - a. Weight: 3.4 lb/sq.yd.

2.3 ACCESSORIES

- A. General: Comply with ASTM C 1063 and coordinate depth of trim and accessories with thicknesses and number of plaster coats required.
- B. Zinc and Zinc-Coated (Galvanized) Accessories:
 - 1. Manufacturers:
 - a. Alabama Metal Industries Corporation (AMICO).
 - b. California Expanded Metal Products Company (CEMCO).
 - c. Dale/Incor.
 - d. Dietrich Industries, Inc.
 - e. Phillips Manufacturing Co.
 - f. Unimast, Inc.
 - g. Western Metal Lath & Steel Framing Systems.
 - 2. G60, hot-dip galvanized zinc coating.
 - 3. Cornerbeads: Fabricated from zinc-coated (galvanized) steel.
 - a. WesCorner 2 ½" x 2 ½" or equivalent.
 - 4. Casing Beads: Fabricated from zinc-coated (galvanized) steel; square-edged style; with expanded flanges.
 - 5. Control Joints: Fabricated from zinc-coated (galvanized) steel; one-piece-type, folded pair of unperforated screeds in M-shaped configuration; with perforated flanges and removable protective tape on plaster face of control joint.

2.4 MISCELLANEOUS MATERIALS

- A. Water for Mixing: Potable and free of substances capable of affecting plaster set or of damaging plaster, lath, or accessories.
- B. Fiber for Base Coat: Alkaline-resistant glass or polypropylene fibers, 1/2 inch long, free of contaminants, manufactured for use in portland cement plaster.
- C. Bonding Compound: ASTM C 932.
- D. Fasteners for Attaching Metal Lath to Substrates: Complying with ASTM C 1063. Attach lath to wood framing, not sheathing, at no less than 16" o.c. each way with approved nails or staples.

2.5 PLASTER MATERIALS

- A. Pre-Mixed Base Coat Product, Fiber Reinforced, for Scratch and Brown Coats:
 - 1. Dryvit Commercial Cement Plaster Base – Sanded, DS817, or
 - 2. Quikrete Commercial Grade Base Coat Stucco.
- B. Fiber Reinforcing: Alkali resistant fibers.

- C. Bag Size: 80 pound sacks.
- D. Ready-Mixed 100% Acrylic Finish-Coat: Shop mixed 100% acrylic finish coating consisting of base, aggregates, coloring agents, and proprietary ingredients.
 - 1. Products:
 - a. Dryvit Standard DPR, or
 - b. Dryvit Elastomeric E DPR.
 - 2. Colors and Texture:
 - a. Dryvit Sandpebble texture with color to match existing building stucco color as selected by Architect from manufacturer's standard colors.
 - b. Other finish coat products are subject to the approval by Architect prior to Bid.

PART 3 - EXECUTION

3.1 EXAMINATION

- A. Examine areas and substrates, with Installer present, and including structural framing, for compliance with requirements and other conditions affecting performance.
 - 1. Proceed with installation only after unsatisfactory conditions have been corrected.

3.2 PREPARATION

- A. Protect adjacent work from soiling, spattering, moisture deterioration, and other harmful effects caused by plastering.

3.3 INSTALLING METAL LATH

- A. Expanded-Metal Lath: Install in strict accordance with ASTM C 1063.
 - 1. Walls and Vertical Framing: Install self-furring diamond-mesh lath.
 - 2. Ceilings and Horizontal Framing: Install self-furring 3/8 diamond-mesh rib lath.

3.4 INSTALLING ACCESSORIES

- A. Install according to ASTM C 1063 and at locations indicated on Drawings.
- B. Reinforcement for External Corners:
 - 1. Install corner reinforcement at all 270 degree corners and edges.

- C. Control Joints and Casing Beads. Install per details on Drawings. Diamond mesh lath shall be installed over control joint and casing bead attachment flanges.

3.5 PLASTER APPLICATION

- A. General: Comply with ASTM C 926.
 - 1. Total plaster thickness shall be 7/8".
 - 2. Total plaster system shall consist of:
 - a. Scratch coat (Portland or Plastic Cement based)
 - b. Brown coat (Portland or Plastic Cement based)
 - c. Finish coat
 - 3. Do not deviate more than plus or minus 1/8 inch in 10 feet from a true plane in finished plaster surfaces, as measured by a 10-foot straightedge placed on surface.
 - 4. Finish plaster flush with built-in metal items that act as a plaster ground, unless otherwise indicated. Where casing bead does not terminate plaster at metal frame, cut base coat free from metal frame before plaster sets and groove finish coat at junctures with metal.
 - 5. Apply 100% acrylic finish coat over approved base coats in strict compliance with manufacturer's recommendations and requirements.
- B. Plaster Finish Coats: Apply to provide smooth, uniform, sand finish to match Architect's sample.

3.6 CUTTING AND PATCHING

- A. Cut, patch, replace, and repair plaster as necessary to accommodate other work and to restore cracks, dents, and imperfections. Repair or replace work to eliminate blisters, buckles, crazing and check cracking, dry outs, efflorescence, sweat outs, and similar defects.

3.7 CLEANING AND PROTECTION

- A. Remove temporary protection and enclosure of other work. Promptly remove plaster from doorframes, windows, and other surfaces not indicated to be plastered. Repair floors, walls, and other surfaces stained, marred, or otherwise damaged during plastering.

END OF SECTION 092400

THIS PAGE INTENTIONALLY BLANK

SECTION 092900 - GYPSUM BOARD

PART 1 - GENERAL

1.1 RELATED DOCUMENTS

- A. Drawings and general provisions of the Contract, including General and Supplementary Conditions and Division 01 Specification Sections, apply to this Section.

1.2 SUMMARY

- A. This Section includes the following:
 - 1. Interior gypsum board.
 - 2. Water resistant gypsum board.
 - 3. Abuse resistant gypsum board.
 - 4. Gypsum board accessories.
- B. See Section 061600 for incidental exterior gypsum sheathing, Section 075423 for roof and parapet substrate board products, and Section 093013 for cementitious backer units behind ceramic tile.

1.3 SUBMITTALS

- A. Product Data: For each type of product indicated.
- B. Samples: For the following products:

1.4 QUALITY ASSURANCE

- A. Fire-Resistance-Rated Assemblies: For fire-resistance-rated assemblies, provide materials and construction identical to those tested in assembly indicated according to ASTM E 119 by an independent testing agency.
- B. Mockups: Before beginning gypsum board installation, install mockups of at least 100 sq. ft. (9 sq. m) in surface area to demonstrate aesthetic effects and set quality standards for materials and execution.
 - 1. Install mockups for the following:
 - a. Each level of gypsum board finish indicated for use in exposed locations.
 - 2. Simulate finished lighting conditions for review of mockups.
 - 3. Approved mockups may become part of the completed Work if undisturbed at time of Substantial Completion.

1.5 STORAGE AND HANDLING

- A. Store materials inside under cover and keep them dry and protected against damage from weather, condensation, direct sunlight, construction traffic, and other causes. Stack panels flat to prevent sagging.

1.6 PROJECT CONDITIONS

- A. Environmental Limitations: Comply with ASTM C 840 requirements or gypsum board manufacturer's written recommendations, whichever are more stringent.
- B. Do not install interior products until installation areas are enclosed and conditioned.
- C. Do not install panels that are wet, those that are moisture damaged, and those that are mold damaged.
 - 1. Indications that panels are wet or moisture damaged include, but are not limited to, discoloration, sagging, or irregular shape.
 - 2. Indications that panels are mold damaged include, but are not limited to, fuzzy or splotchy surface contamination and discoloration.

PART 2 - PRODUCTS

2.1 PANELS, GENERAL

- A. Size: Provide in maximum lengths and widths available that will minimize joints in each area and that correspond with support system indicated.

2.2 GYPSUM BOARD AND SHEATHING

- A. General: Complying with ASTM C 36/C 36M or ASTM C 1396/C 1396M, as applicable to type of gypsum board indicated and whichever is more stringent.
 - 1. Manufacturers: Subject to compliance with requirements, provide products by one of the following:
 - a. G-P Gypsum. (except abuse resistant)
 - b. National Gypsum Company. (except abuse resistant)
 - c. USG Corporation.
- B. Products by other manufacturers are subject to approval by Architect prior to bidding.
- C. Gypsum Wallboard (and Backing Board at Multi-Layer Applications): ASTM C 36 and as follows:
 - 1. Type: Type X.
 - 2. Edges: Tapered (Square at Backing Board).
 - 3. Thickness: 5/8 inch. (Double 1/2 inch at digitally printed mural location)

D. Water-Resistant Gypsum Backing Board: ASTM C 630 and as follows:

1. Type: Type X.
2. Edges: Square.
3. Thickness: 5/8 inch.

E. Abuse-Resistant Gypsum Board:

1. Type: Type X, USG Fiberock Abuse – Resistant Gypsum Panel.
2. Edges: Tapered.
3. Thickness: 5/8 inch.

2.3 TRIM ACCESSORIES

A. Interior Trim: ASTM C 1047.

1. Material: Galvanized or aluminum-coated steel sheet.
2. Shapes:
 - a. Cornerbead.
 - b. LC-Bead: J-shaped; exposed long flange receives joint compound.
 - c. L-Bead: L-shaped; exposed long flange receives joint compound.

2.4 JOINT TREATMENT MATERIALS

A. General: Comply with ASTM C 475/C 475M.

B. Joint Tape:

1. Interior Gypsum Wallboard: Paper.

C. Joint Compound for Interior Gypsum Wallboard: For each coat use formulation that is compatible with other compounds applied on previous or for successive coats.

1. Prefilling: At open joints and damaged surface areas, use setting-type taping compound.
2. Embedding and First Coat: For embedding tape and first coat on joints, fasteners, and trim flanges, use setting-type, heavy-weight compound.
 - a. Use setting-type compound for installing paper-faced metal trim accessories.
3. Fill Coat: For second coat, use drying-type, all-purpose compound.
4. Finish Coat: For third coat, use drying-type, all-purpose compound.

2.5 AUXILIARY MATERIALS

A. General: Provide auxiliary materials that comply with referenced installation standards and manufacturer's written recommendations.

- B. Laminating Adhesive: Adhesive or joint compound recommended for directly adhering gypsum panels to continuous substrate.
 - 1. Use adhesives that have a VOC content of 50 g/L or less when calculated according to 40 CFR 59, Subpart D (EPA Method 24).
- C. Steel Drill Screws: ASTM C 1002, unless otherwise indicated.
 - 1. Use screws complying with ASTM C 954 for fastening panels to steel members from 0.033 to 0.112 inch (0.84 to 2.84 mm) thick.
 - 2. For fastening cementitious backer units, use screws of type and size recommended by panel manufacturer.

PART 3 - EXECUTION

3.1 EXAMINATION

- A. Examine areas and substrates, with Installer present, and including welded hollow-metal frames and framing, for compliance with requirements and other conditions affecting performance.
- B. Examine panels before installation. Reject panels that are wet, moisture damaged, and mold damaged.
- C. Proceed with installation only after unsatisfactory conditions have been corrected.

3.2 APPLYING AND FINISHING PANELS, GENERAL

- A. Comply with ASTM C 840.
- B. Install panels with face side out. Butt panels together for a light contact at edges and ends with not more than 1/16 inch (1.5 mm) of open space between panels. Do not force into place.
- C. Locate edge and end joints over supports, except in ceiling applications where intermediate supports or gypsum board back-blocking is provided behind end joints. Do not place tapered edges against cut edges or ends. Stagger vertical joints on opposite sides of partitions. Do not make joints other than control joints at corners of framed openings.
- D. Cover both faces of support framing with gypsum panels in concealed spaces (above ceilings, etc.), except in chases braced internally.
 - 1. Unless concealed application is indicated or required for sound, fire, air, or smoke ratings, coverage may be accomplished with scraps of not less than 8 sq. ft. (0.7 sq. m) in area.
 - 2. Fit gypsum panels around ducts, pipes, and conduits.
 - 3. Where partitions intersect structural members projecting below underside of floor/roof slabs and decks, cut gypsum panels to fit profile formed by structural members; allow 1/4- to 3/8-inch- (6.4- to 9.5-mm-) wide joints to install sealant.

- E. Isolate perimeter of gypsum board applied to non-load-bearing partitions at structural abutments, except floors. Provide 1/4- to 1/2-inch- (6.4- to 12.7-mm-) wide spaces at these locations, and trim edges with edge trim where edges of panels are exposed. Seal joints between edges and abutting structural surfaces with acoustical sealant. Isolation joints are required between gypsum board and masonry walls whether or not masonry is structural.
- F. Attachment to Steel Framing: Attach panels so leading edge or end of each panel is attached to open (unsupported) edges of stud flanges first.

3.3 APPLYING INTERIOR GYPSUM BOARD

- A. Install interior gypsum board in the following locations:
 - 1. Type X: As indicated on Drawings.
- B. Single-Layer Application:
 - 1. On partitions/walls, apply gypsum panels horizontally (perpendicular to framing), unless otherwise indicated or required by fire-resistance-rated assembly, and minimize end joints.
 - a. Stagger abutting end joints not less than one framing member in alternate courses of panels.
 - b. At stairwells and high walls, install panels horizontally, unless otherwise indicated or required by fire-resistance-rated assembly.
 - 2. Attach gypsum board to framing with screws at 6 inches o.c. at perimeter and 8 inches o.c. in field.
 - 3. Fastening Methods: Apply gypsum panels to supports with steel drill screws.
- C. Single and Double Layer Fastening Methods: Apply gypsum panels to supports as follows:
 - 1. Fasten with screws of lengths indicated to studs and ceiling framing. Spacing per single layer requirements.
 - a. Minimum 1" long screws at first layer 1/2" and 5/8" board.
 - b. Minimum 1 5/8" long screws at second layer 1/2" and 5/8" board.
 - 2. Offset joints in second layer minimum four feet horizontally and two feet vertically from first layer.
- D. Laminating to Substrate: Where gypsum panels are indicated as directly adhered to a substrate (other than studs, joists, furring members, or base layer of gypsum board), comply with gypsum board manufacturer's written recommendations and temporarily brace or fasten gypsum panels until fastening adhesive has set.
- E. Abuse Resistant Board Application: Attach boards to stud framing full height at restroom walls not receiving ceramic tile, and at other specified locations. Stagger end joints where applicable.

Attach to wall framing with minimum 1 inch long screws at 12 inches o.c. and 3/8 inch from ends and edges of panel.

3.4 APPLYING EXTERIOR GYPSUM SHEAR WALL BOARD SHEATHING AND SUBSTRATE BOARD

- A. Gypsum Shear Wall Sheathing: Install over light gauge metal framing at all shear wall locations and as specified on the documents.
- B. Substrate Board: Install over light gauge metal framing at interior face of parapet walls per details on Drawings.
- C. Substrate Board Fasteners: Fasteners shall be minimum 1 inch screws spaced 8 inches o.c. along framing members.
- D. Shear Wall Board Fasteners: Install per manufacturer's recommendation and as directed by the Structural Engineering Documents. Structural notes and details to take precedence.

3.5 INSTALLING TRIM ACCESSORIES

- A. General: For trim with back flanges intended for fasteners, attach to framing with same fasteners used for panels. Otherwise, attach trim according to manufacturer's written instructions.
- B. Interior Trim: Install in the following locations:
 - 1. Cornerbead: Use at outside corners.
 - 2. LC-Bead: Use at exposed panel edges.
 - 3. L-Bead: Use only where indicated.

3.6 FINISHING GYPSUM BOARD

- A. General: Treat gypsum board joints, interior angles, edge trim, control joints, penetrations, fastener heads, surface defects, and elsewhere as required to prepare gypsum board surfaces for decoration. Promptly remove residual joint compound from adjacent surfaces.
- B. Prefill open joints and damaged surface areas.
- C. Apply joint tape over gypsum board joints, except those with trim having flanges not intended for tape.
- D. Gypsum Board Finish Levels: Finish panels to levels indicated below and according to ASTM C 840:
 - 1. Level 1: Ceiling plenum areas, concealed areas, and where indicated.
 - 2. Level 2: Panels that are substrate for fiberglass reinforced panels.
 - 3. Level 4: Panel surfaces that will be exposed to view and are substrate for non-graphic wall coverings. Apply very light orange peel texture at surfaces to be painted unless in

close proximity to surfaces with either no texture or heavier texture. Consult with Architect regarding specific conditions.

- a. Primer and its application to surfaces are specified in other Division 09 Sections. Gypsum board shall be pre-primed prior to applying texture.

4. Level 5: At surfaces to receive graphic vinyl wall covering applications.

3.7 PROTECTION

- A. Protect installed products from damage from weather, condensation, direct sunlight, construction, and other causes during remainder of the construction period.
- B. Remove and replace panels that are wet, moisture damaged, and mold damaged.
 1. Indications that panels are wet or moisture damaged include, but are not limited to, discoloration, sagging, or irregular shape.
 2. Indications that panels are mold damaged include, but are not limited to, fuzzy or splotchy surface contamination and discoloration.

- 3.8 Abuse Resistant Gypsum Board Finishing: Apply joint compound in strict accordance with manufacturer recommendations to Level 4 requirements. At restrooms, apply Sheetrock Brand "Tuff-Hide" primer – surfacer to wet film thickness of 15 mils. At all other locations, pre-prime by painting contractor. Spray very light orange peel texture over primer-surfacer / pre-prime coat per Paragraph 3.6.

END OF SECTION 092900

THIS PAGE INTENTIONALLY BLANK

SECTION 093013 – TILING

PART 1 - GENERAL

1.1 RELATED DOCUMENTS

- A. Drawings and general provisions of the Contract, including General and Supplementary Conditions and Division 01 Specification Sections, apply to this Section.

1.2 SUMMARY

- A. This Section includes the following:
 - 1. Glazed wall tile.
 - 2. Unglazed porcelain floor tile.
 - 3. Tile backing panels.
 - 4. Mortar and grout.
 - 5. Liquid waterproofing.

1.3 SUBMITTALS

- A. Product Data: For each type of product indicated.
- B. Samples for Selection: For each type of tile and grout indicated.
- C. Samples for Verification:
 - 1. Full-size units of each type and composition of tile and for each color and finish required.

1.4 QUALITY ASSURANCE

- A. Source Limitations for Tile: Obtain all tile of same type and color or finish from one source or producer.
 - 1. Obtain tile from same production run and of consistent quality in appearance and physical properties for each contiguous area.
- B. Source Limitations for Setting and Grouting Materials: Obtain ingredients of a uniform quality for each mortar, adhesive, and grout component from a single manufacturer and each aggregate from one source or producer.

1.5 DELIVERY, STORAGE, AND HANDLING

- A. Deliver and store packaged materials in original containers with seals unbroken and labels intact until time of use. Comply with requirement in ANSI A137.1 for labeling sealed tile packages.
- B. Store tile and cementitious materials on elevated platforms, under cover, and in a dry location.
- C. Store aggregates where grading and other required characteristics can be maintained and contamination avoided.
- D. Store liquid latexes and emulsion adhesives in unopened containers and protected from freezing.
- E. Handle tile that has temporary protective coating on exposed surfaces to prevent coated surfaces from contacting backs or edges of other units. If coating does contact bonding surfaces of tile, remove coating from bonding surfaces before setting tile.

1.6 PROJECT CONDITIONS

- A. Environmental Limitations: Do not install tile until construction in spaces is complete and ambient temperature and humidity conditions are maintained at the levels indicated in referenced standards and manufacturer's written instructions.

PART 2 - PRODUCTS

2.1 MANUFACTURERS

- A. In other Part 2 articles where titles below introduce lists, the following requirements apply for product selection:
 - 1. Manufacturers / Products: Subject to compliance with requirements, provide one of the manufacturers / products specified.

2.2 PRODUCTS, GENERAL

- A. ANSI Ceramic Tile Standard: Provide tile that complies with ANSI A137.1, "Specifications for Ceramic Tile," for types, compositions, and other characteristics indicated.
- B. ANSI Standards for Tile Installation Materials: Provide materials complying with ANSI standards referenced in "Setting and Grouting Materials" Article.
- C. Factory Blending: For tile exhibiting color variations within ranges, blend tile in factory and package so tile units taken from one package show same range in colors as those taken from other packages and match approved Samples.
- D. Mounting: For factory-mounted tile, provide back- or edge-mounted tile assemblies as standard with manufacturer, unless otherwise indicated.

1. Where tile is indicated for installation in wet areas, do not use back- or edge-mounted tile assemblies unless tile manufacturer specifies in writing that this type of mounting is suitable for installation indicated and has a record of successful in-service performance.
- E. Factory-Applied Temporary Protective Coating: Where indicated under tile type, protect exposed surfaces of tile against adherence of mortar and grout by precoating with continuous film of petroleum paraffin wax, applied hot. Do not coat unexposed tile surfaces.

2.3 TILE PRODUCTS

A. Glazed Wall Tile: Flat tile as follows:

1. Module Size: 6 by 6 inches.
2. Thickness: 5/16 inch (8 mm).
3. Face: Plain with cushion edges.
4. Finish: glaze, as selected by the Architect.
5. Manufacturer / Product:
 - a. Daltile: Maximum of 3 total standard colors and 3 total premium priced colors.
 - b. American Olean: Maximum of 3 total standard colors and 3 total premium priced colors.
 - c. Maximum of 1 standard color and 1 premium priced color shall be used in any given room. Amount of premium priced tile shall not exceed 20% of the tile in any given room or location.

B. Unglazed Porcelain Floor Tile: Flat tile as follows:

1. Module size 2 x 2 inches.
2. Thickness: 5/16 inch (8mm)
3. Face: Plain with cushion edges.
4. Manufacturer / Product:
 - a. Daltile: Maximum of 2 total colors.
 - b. American Olean: Maximum of 2 total colors.
 - c. Maximum of 1 color shall be used in any given room or location.

2.4 SETTING AND GROUTING MATERIALS

A. Manufacturers:

1. Bonsal, W. R., Company.
2. LATICRETE International Inc.
3. MAPEI Corporation.
4. Southern Grouts & Mortars, Inc.
5. Summitville Tiles, Inc.

B. Latex-Portland Cement Mortar (Thin Set): ANSI A118.4, consisting of the following:

1. Prepackaged dry-mortar mix combined with acrylic resin liquid-latex additive.
 - a. For wall applications, provide non-sagging mortar.
- C. Polymer-Modified Tile Grout: ANSI A118.7, color as selected by Architect. Colored gout shall be utilized.
 1. Polymer Type: Acrylic resin in liquid-latex form for addition to prepackaged dry-grout mix.
 - a. Unsanded grout mixture for joints 1/8 inch (3.2 mm) and narrower.
 - b. Sanded grout mixture for joints 1/8 inch (3.2 mm) and wider.

2.5 TILE BACKING PANELS

- A. Cementitious Backer Units: 5/8" thick panels per ASTM C1325 or ANSI A118.9. USG Durock or equivalent.

2.6 MISCELLANEOUS MATERIALS

- A. Trowelable Underlayments and Patching Compounds: Latex-modified, portland cement-based formulation provided or approved by manufacturer of tile-setting materials for installations indicated.
- B. Temporary Protective Coating: Coating that is formulated to protect exposed surfaces of tile against adherence of mortar and grout; compatible with tile, mortar, and grout products; and easily removable after grouting is completed without damaging grout or tile.
 1. Grout release in form of manufacturer's standard proprietary liquid coating that is specially formulated and recommended for use as temporary protective coating for tile.
- C. Tile Cleaner: A neutral cleaner capable of removing soil and residue without harming tile and grout surfaces, specifically approved for materials and installations indicated by tile and grout manufacturers.
- D. Grout Sealer: Manufacturer's standard product for sealing grout joints that does not change color or appearance of grout.
 1. Manufacturers / Products:
 - a. Bonsal, W. R., Company; Grout Sealer.
 - b. Southern Grouts & Mortars, Inc.; Silicone Grout Sealer.
 - c. Summitville Tiles, Inc.; SL-15, Invisible Seal Penetrating Grout and Tile Sealer.
- E. Liquid Waterproofing Membrane: Product to comply with ASNI A118.10.

- F. Metal Edge Strips: Angle or L-shaped, height to match tile and setting bed thickness, metallic or combination of metal and PVC or neoprene base designed for specific flooring applications; stainless steel, ASTM A666, 300 Series exposed edge material.
 - 1. Products: Subject to compliance with requirements, available products that may be incorporated into the Work include, but are not limited to the following:
 - a. Schluter Systems:
 - 1. RENO-U: Floor tile to concrete or resilient flooring.
 - 2. RENO-TK: Floor tile to carpet.
 - b. Finish: Stainless steel.

2.7 MIXING MORTARS AND GROUT

- A. Mix mortars and grouts to comply with referenced standards and mortar and grout manufacturers' written instructions.
- B. Add materials, water, and additives in accurate proportions.
- C. Obtain and use type of mixing equipment, mixer speeds, mixing containers, mixing time, and other procedures to produce mortars and grouts of uniform quality with optimum performance characteristics for installations indicated.

PART 3 - EXECUTION

3.1 EXAMINATION

- A. Examine substrates, areas, and conditions where tile will be installed, with Installer present, for compliance with requirements for installation tolerances and other conditions affecting performance of installed tile.
 - 1. Verify that substrates for setting tile are firm; dry; clean; free of oil, waxy films, and curing compounds; and within flatness tolerances required by referenced ANSI A108 Series of tile installation standards for installations indicated.
 - 2. Verify that installation of grounds, anchors, recessed frames, electrical and mechanical units of work, and similar items located in or behind tile has been completed before installing tile.
 - 3. Verify that joints and cracks in tile substrates are coordinated with tile joint locations; if not coordinated, adjust joint locations in consultation with Architect.
- B. Proceed with installation only after unsatisfactory conditions have been corrected.

3.2 PREPARATION

- A. Remove coatings, including curing compounds and other substances that contain soap, wax, oil, or silicone, that are incompatible with tile-setting materials.

- B. Provide concrete substrates for tile floors installed with thin-set mortar that comply with flatness tolerances specified in referenced ANSI A108 Series of tile installation standards.
 - 1. Fill cracks, holes, and depressions with trowelable leveling and patching compound according to tile-setting material manufacturer's written instructions. Use product specifically recommended by tile-setting material manufacturer.
 - 2. Remove protrusions, bumps, and ridges by sanding or grinding.
- C. Blending: For tile exhibiting color variations within ranges selected during Sample submittals, verify that tile has been factory blended and packaged so tile units taken from one package show same range of colors as those taken from other packages and match approved Samples. If not factory blended, either return to manufacturer or blend tiles at Project site before installing.
- D. Field-Applied Temporary Protective Coating: Where indicated under tile type or needed to prevent grout from staining or adhering to exposed tile surfaces, precoat them with continuous film of temporary protective coating, taking care not to coat unexposed tile surfaces.

3.3 INSTALLATION, GENERAL

- A. ANSI Tile Installation Standards: Comply with parts of ANSI A108 Series "Specifications for Installation of Ceramic Tile" that apply to types of setting and grouting materials and to methods indicated in ceramic tile installation schedules.
- B. TCA Installation Guidelines: Tile Council of America (TCA) "Handbook for Ceramic Tile Installation." Comply with TCA installation methods indicated in ceramic tile installation schedules.
- C. Extend tile work into recesses and under or behind equipment and fixtures to form complete covering without interruptions, unless otherwise indicated. Terminate work neatly at obstructions, edges, and corners without disrupting pattern or joint alignments.
- D. Accurately form intersections and returns. Perform cutting and drilling of tile without marring visible surfaces. Carefully grind cut edges of tile abutting trim, finish, or built-in items for straight aligned joints. Fit tile closely to electrical outlets, piping, fixtures, and other penetrations so plates, collars, or covers overlap tile.
- E. Jointing Pattern: Lay tile in grid pattern, unless otherwise indicated. Align joints when adjoining tiles on floor, base, walls, and trim are same size. Lay out tile work and center tile fields in both directions in each space or on each wall area. Adjust to minimize tile cutting. Provide uniform joint widths, unless otherwise indicated.
 - 1. For tile mounted in sheets, make joints between tile sheets same width as joints within tile sheets so joints between sheets are not apparent in finished work.
- F. Lay out tile wainscots to next full tile beyond dimensions indicated.
- G. Grout tile to comply with requirements of the following tile installation standards:
 - 1. For ceramic tile grouts (sand-portland cement; dry-set, commercial portland cement; and latex-portland cement grouts), comply with ANSI A108.10.

- H. Install waterproofing membrane to comply with ANSI A108.13 and waterproofing manufacturer's written instructions to produce waterproof membrane of uniform thickness bonded securely to concrete floor substrate and backer units.

3.4 FLOOR TILE INSTALLATION

- A. General: Install tile to comply with requirements in the Floor Tile Installation Schedule, including those referencing TCA installation methods and ANSI A108.6 Series of tile installation standards.
 - 1. For installations indicated below, follow procedures in ANSI A108 Series tile installation standards for providing 95 percent mortar coverage.
 - a. Unglazed porcelain tile in restrooms, install per TCA F122.
- B. Metal Edge Strips: Install at locations indicated or where exposed edge of tile flooring meets carpet, wood, or other flooring that finishes flush with top of tile.
- C. Grout Sealer: Apply grout sealer to grout joints according to grout-sealer manufacturer's written instructions. As soon as grout sealer has penetrated grout joints, remove excess sealer and sealer that has gotten on tile faces by wiping with soft cloth.

3.5 WALL TILE INSTALLATION

- A. Install types of tile designated for wall installations to comply with requirements in the Wall Tile Installation Schedule, including those referencing TCA installation methods and ANSI setting-bed standards. Install per TCA W244C at wood stud walls and TCA W202 at concrete masonry unit walls.

3.6 CLEANING AND PROTECTING

- A. Cleaning: On completion of placement and grouting, clean all ceramic tile surfaces so they are free of foreign matter.
 - 1. Remove latex-portland cement grout residue from tile as soon as possible.
 - 2. Clean grout smears and haze from tile according to tile and grout manufacturer's written instructions, but no sooner than 10 days after installation. Use only cleaners recommended by tile and grout manufacturers and only after determining that cleaners are safe to use by testing on samples of tile and other surfaces to be cleaned. Protect metal surfaces and plumbing fixtures from effects of cleaning. Flush surfaces with clean water before and after cleaning.
 - 3. Remove temporary protective coating by method recommended by coating manufacturer that is acceptable to tile and grout manufacturer. Trap and remove coating to prevent it from clogging drains.

- B. When recommended by tile manufacturer, apply coat of neutral protective cleaner to completed tile walls and floors. Protect installed tile work with kraft paper or other heavy covering during construction period to prevent staining, damage, and wear.
- C. Prohibit foot and wheel traffic from tiled floors for at least seven days after grouting is completed.
- D. Before final inspection, remove protective coverings and rinse neutral cleaner from tile surfaces.

3.7 FLOOR TILE INSTALLATION SCHEDULE

- A. Tile installation at restroom floors: Interior floor installation over concrete and liquid waterproofing membrane with thin-set mortar per TCA F122.
 - 1. Tile Type: Unglazed porcelain floor tile.
 - 2. Thin-Set Mortar: Latex-Portland cement mortar.
 - 3. Grout: Latex-Portland cement grout.
 - 4. Pattern: Single color.

3.8 WALL TILE INSTALLATION SCHEDULE

- A. Tile installation at restrooms and drinking fountain alcove over wood stud and CMU walls: Interior wall installation over cementitious backing panels with thin-set mortar per TCA W244C / TCA W202 as applicable.
 - 1. Tile Type: Glazed wall tile.
 - 2. Thin-Set Mortar: Latex- portland cement mortar.
 - 3. Grout: Polymer-modified grout.
 - 4. Pattern: Single accent color pattern(20% of wall area) to be provided by Architect.

END OF SECTION 093013

SECTION 095113 - ACOUSTICAL PANEL CEILINGS

PART 1 - GENERAL

1.1 RELATED DOCUMENTS

- A. Drawings and general provisions of the Contract, including General and Supplementary Conditions and Division 01 Specification Sections, apply to this Section.

1.2 SUMMARY

- A. This Section includes acoustical panels and exposed suspension systems for ceilings.
- B. This Section also includes removal and reinstallation of existing panels as required to provide access for work by other trades, and replacement of grid and panels damaged during construction.

1.3 DEFINITIONS

- A. AC: Articulation Class.
- B. CAC: Ceiling Attenuation Class.
- C. LR: Light Reflectance coefficient.
- D. NRC: Noise Reduction Coefficient.

1.4 SUBMITTALS

- A. Product Data: For each type of product indicated. Ceiling system engineering and/or certification that ceiling suspension system complies with locally applicable provisions of the International Building Code and referenced ASTM standards is required per IBC Sections 803.9.1.1 and 1613.1.
- B. Fasteners and Anchors: Submit proposed fasteners for attachment of wall trim to steel studs and masonry, and attachment of wire hangers to concrete slab on deck.

1.5 QUALITY ASSURANCE

- A. Source Limitations:
 - 1. Acoustical Ceiling Panel: Obtain each type through one source from a single manufacturer.
 - 2. Suspension System: Obtain each type through one source from a single manufacturer.

- B. Fire-Test-Response Characteristics: Provide acoustical panel ceilings that comply with the following requirements:
 - 1. Fire-Resistance Characteristics: Where indicated, provide acoustical panel ceilings identical to those of assemblies tested for fire resistance per ASTM E 119 by UL or another testing and inspecting agency acceptable to authorities having jurisdiction.
 - 2. Surface-Burning Characteristics: Provide acoustical panels with the following surface-burning characteristics complying with ASTM E 1264 for Class A materials as determined by testing identical products per ASTM E 84:
 - a. Smoke-Developed Index: 450 or less.
- C. Seismic Standard: Provide acoustical panel ceilings designed and installed to withstand the effects of earthquake motions according to the following:
 - 1. Suspended acoustical ceiling systems shall be installed in accordance with the provisions of ASTM C 635, ASTM C 636 and the structural requirements in IBC Chapter 16 and ASCE 7 Section 13.5.6. Ceiling engineering done by the manufacturer and incorporated into its installation instructions is acceptable.

1.6 DELIVERY, STORAGE, AND HANDLING

- A. Deliver acoustical panels, suspension system components, and accessories to Project site in original, unopened packages and store them in a fully enclosed, conditioned space where they will be protected against damage from moisture, humidity, temperature extremes, direct sunlight, surface contamination, and other causes.
- B. Before installing acoustical panels, permit them to reach room temperature and a stabilized moisture content.
- C. Handle acoustical panels carefully to avoid chipping edges or damaging units in any way.

1.7 PROJECT CONDITIONS

- A. Environmental Limitations: Do not install acoustical panel ceilings until spaces are enclosed and weatherproof, wet work in spaces is complete and dry, work above ceilings is complete, and ambient temperature and humidity conditions are maintained at the levels indicated for Project when occupied for its intended use.

1.8 COORDINATION

- A. Coordinate layout and installation of acoustical panels and suspension system with other construction that penetrates ceilings or is supported by them, including light fixtures, HVAC equipment, fire-suppression system, and partition assemblies.

1.9 EXTRA MATERIALS

- A. Furnish extra materials described below that match products installed and that are packaged with protective covering for storage and identified with labels describing contents.
 - 1. Acoustical Ceiling Panels: Full-size panels equal to 2.0 percent of quantity installed.
 - 2. Suspension System Components: Quantity of each exposed component equal to 2.0 percent of quantity installed.

PART 2 - PRODUCTS

2.1 ACOUSTICAL PANELS, GENERAL

- A. Acoustical Panel Standard: Provide manufacturer's standard panels of configuration indicated that comply with ASTM E 1264 classifications as designated by types, patterns, acoustical ratings, and light reflectance, unless otherwise indicated.
 - 1. Mounting Method for Measuring NRC: Type E-400; plenum mounting in which face of test specimen is 15-3/4 inches (400 mm) away from test surface per ASTM E 795.
- B. Acoustical Panel Colors and Patterns: Match appearance characteristics indicated for each product type.
 - 1. Where appearance characteristics of acoustical panels are indicated by referencing pattern designations in ASTM E 1264 and not manufacturers' proprietary product designations, provide products selected by Architect from each manufacturer's full range that comply with requirements indicated for type, pattern, color, light reflectance, acoustical performance, edge detail, and size.
- C. Broad Spectrum Antimicrobial Fungicide and Bactericide Treatment: Provide acoustical panels treated with manufacturer's standard antimicrobial formulation that inhibits fungus, mold, mildew, and gram-positive and gram-negative bacteria and showing no mold, mildew, or bacterial growth when tested according to ASTM D 3273 and evaluated according to ASTM D 3274 or ASTM G 21.

2.2 ACOUSTICAL PANELS FOR ACOUSTICAL PANEL CEILING

- A. Manufacturers: Subject to compliance with requirements, provide products by one of the following:
 - 1. Armstrong World Industries, Inc.;
 - 2. USG Interiors, Inc.;
 - 3. CertainTeed
- B. Products by other manufacturers are subject to approval by the Architect prior to bidding.
- C. General Use Panels: Provide panels complying with ASTM E 1264 for type, form, and pattern as follows:

1. Equal to Armstrong "School Zone Fine Fissured".
2. Type and Form: Type III, mineral base with painted finish; wet formed.
3. Pattern: D (fissured).
4. Color: White.
5. LR: Not less than 0.85.
6. NRC: Not less than 0.55.
7. CAC: Not less than 35.
8. Edge/Joint Detail: Square.
9. Thickness: 5/8 inch (15 mm).
10. Modular Size: 24 by 48 inches (610 by 1220 mm).
11. Antimicrobial Treatment: broad spectrum fungicide and bactericide fungicide based.

- D. Washable, Vinyl Faced Panels: Panels shall be USG Sheetrock "ClimaPlus", ½". Color: White. Location: Kitchen areas per Drawings.
- E. Aluminum Pan Panels: Panels shall be USG "Panz" smooth panel with square edge. Color: White. Location: Perimeter of kitchen hood where non-combustible panels are required.
- F. Impact Resistant Panels: Panels shall be Armstrong School Zone fine fissured "High Durability", or equivalent product by USG. Color: White. Location: Gymnasium direct- attached acoustical sound panel detail.

2.3 METAL SUSPENSION SYSTEMS, GENERAL

- A. Metal Suspension System Standard: Provide manufacturer's standard direct-hung metal suspension systems of types, structural classifications, and finishes indicated that comply with applicable requirements in ASTM C 635.
- B. Finishes and Colors, General: Comply with NAAMM's "Metal Finishes Manual for Architectural and Metal Products" for recommendations for applying and designating finishes. Provide manufacturer's standard factory-applied finish for type of system indicated.
- C. Attachment Devices: Size for five times the design load indicated in ASTM C 635, Table 1, "Direct Hung," unless otherwise indicated. Comply with seismic design requirements.
- D. Wire Hangers, Braces, and Ties: Provide wires complying with the following requirements:
1. Zinc-Coated, Carbon-Steel Wire: ASTM A 641/A 641M, Class 1 zinc coating, soft temper.
- E. Seismic Struts: Manufacturer's standard compression struts designed to accommodate seismic forces.
- F. Seismic Clips: Manufacturer's standard seismic clips designed and spaced to secure acoustical panels in-place.

2.4 METAL SUSPENSION SYSTEM FOR ACOUSTICAL PANEL CEILINGS

- A. Manufacturers: Subject to compliance with requirements, provide products by one of the following:
1. Armstrong World Industries, Inc.;
 2. Chicago Metallic Corporation;
 3. USG Interiors, Inc.;
 4. CertainTeed.
- B. Products by other manufacturers are subject to approval by Architect prior to bidding.
- C. Wide-Face, Capped, Double-Web, Steel Suspension System: Main and cross runners roll formed from cold-rolled steel sheet, prepainted, electrolytically zinc coated, or hot-dip galvanized according to ASTM A 653/A 653M, not less than G30 (Z90) coating designation, with prefinished 15/16-inch- (24-mm-) wide metal caps on flanges.
1. Structural Classification: Intermediate-duty system.
 2. End Condition of Cross Runners: Override (stepped) or butt-edge type.
 3. Face Design: Flat, flush.
 4. Cap Material: Steel cold-rolled sheet.
 5. Cap Finish: Painted white.
- D. Roll-Formed, Sheet-Metal Edge Moldings and Trim: Type and profile indicated or, if not indicated, manufacturer's standard moldings for edges and penetrations that comply with seismic design requirements; formed from sheet metal of same material, finish, and color as that used for exposed flanges of suspension system runners.
1. Provide manufacturer's standard edge moldings that fit acoustical panel edge details and suspension systems indicated and that match width and configuration of exposed runners, unless otherwise indicated.
 2. For lay-in panels with reveal edge details, provide stepped edge molding that forms reveal of same depth and width as that formed between edge of panel and flange at exposed suspension member.
 3. For circular penetrations of ceiling, provide edge moldings fabricated to diameter required to fit penetration exactly.

PART 3 - EXECUTION

3.1 EXAMINATION

- A. Examine substrates, areas, and conditions, including structural framing to which acoustical panel ceilings attach or abut, with Installer present, for compliance with requirements specified in this and other Sections that affect ceiling installation and anchorage and with requirements for installation tolerances and other conditions affecting performance of acoustical panel ceilings.
1. Proceed with installation only after unsatisfactory conditions have been corrected.

3.2 PREPARATION

- A. Measure each ceiling area and establish layout of acoustical panels to balance border widths at opposite edges of each ceiling. Avoid using less-than-half-width panels at borders, and comply with layout shown on reflected ceiling plans.
- B. Remove panels as directed by General Contractor to permit work by other trades. Reinstall panels upon completion of work. Replace damaged panels and grid, matching existing where possible.

3.3 INSTALLATION

- A. General: Install acoustical panel ceilings to comply with ASTM C636, ASTM C635, structural requirements of IBC Chapter 16, and ASCE 7, Section 13.5.6, for seismic design requirements. Installation shall also comply with manufacturer's written instructions and CISCA's "Ceiling Systems Handbook."
- B. Suspend ceiling hangers from building's structural members and as follows:
 - 1. Install hangers plumb and free from contact with insulation or other objects within ceiling plenum that are not part of supporting structure or of ceiling suspension system.
 - 2. Splay hangers only where required to miss obstructions; offset resulting horizontal forces by bracing, countersplaying, or other equally effective means.
 - 3. Splay hangers only where required due to spacing of structural members. Offset by bracing, counter splaying, or other equally effective means.
 - 4. Where width of ducts and other construction within ceiling plenum produces hanger spacings that interfere with location of hangers at spacings required to support standard suspension system members, install supplemental suspension members and hangers in form of trapezes or equivalent devices.
 - 5. Secure wire hangers to ceiling suspension members and to supports above with a minimum of three tight turns. Connect hangers directly to structural members.
 - 6. When roof framing does not permit installation of hanger wires at spacing required, install carrying channels or other supplemental support for attachment of hanger wires.
 - 7. Do not attach hangers to roof deck. Attach hangers to structural members, such as trusses joists, beams, etc, and concrete on metal deck.
 - 8. Space hangers not more than 48 inches (1200 mm) o.c. along each member supported directly from hangers, unless otherwise indicated; provide hangers not more than 8 inches (200 mm) from ends of each member.
 - 9. Size supplemental suspension members and hangers to support ceiling loads within performance limits established by referenced standards and publications.
 - 10. Install gymnasium direct-attached ceiling panels in fixed frames directly attached to roof deck per details on Drawings.
- C. Secure bracing wires to ceiling suspension members and to supports with a minimum of four tight turns. Suspend bracing from building's structural members as required for hangers, without attaching to permanent metal forms, steel deck, or steel deck tabs.
- D. Install edge moldings and trim of type indicated at perimeter of acoustical ceiling area and where necessary to conceal edges of acoustical panels.

1. Screw attach moldings to substrate at intervals not more than 16 inches (400 mm) o.c. and not more than 3 inches (75 mm) from ends, leveling with ceiling suspension system to a tolerance of 1/8 inch in 12 feet (3.2 mm in 3.6 m). Miter corners accurately and connect securely.
- E. Install suspension system runners so they are square and securely interlocked with one another. Remove and replace dented, bent, or kinked members.
- F. Install acoustical panels with undamaged edges and fit accurately into suspension system runners and edge moldings. Scribe and cut panels at borders and penetrations to provide a neat, precise fit.
1. For square-edged panels, install panels with edges fully hidden from view by flanges of suspension system runners and moldings.
 2. For reveal-edged panels on suspension system runners, install panels with bottom of reveal in firm contact with top surface of runner flanges.
 3. Install hold-down clips in all vestibules and in areas required by authorities having jurisdiction. Space as recommended by panel manufacturer's written instructions, unless otherwise indicated.
 - a. Install metal pan panels with hold-down clips.

3.4 CLEANING

- A. Clean exposed surfaces of acoustical panel ceilings, including trim, edge moldings, and suspension system members. Comply with manufacturer's written instructions for cleaning and touchup of minor finish damage. Remove and replace ceiling components that cannot be successfully cleaned and repaired to permanently eliminate evidence of damage.

END OF SECTION 095113

THIS PAGE INTENTIONALLY BLANK

SECTION 096466 – WOOD ATHLETIC FLOORING

PART 1 - GENERAL

1.1. RELATED DOCUMENTS

- A. Drawings and general provisions of the Contract, including General and Supplementary Conditions and Division 1 Specification Sections, apply to this Section.

1.2. SUMMARY

- A. This Section includes the following types of interior wood flooring:
 - 1. Wood strip flooring on double plywood substrate supported by resilient pads at the gymnasium floor and at the stage in front of the stage curtain line.
 - 2. Triple plywood system supported by resilient pads at the stage floor starting at the stage curtain line and extending to the back stage wall.

1.3. SUBMITTALS

- A. General: Submit the following according to Conditions of Contract and Division 1 Specification Sections.
- B. Product data including manufacturer's detailed technical product data and installation instructions for each type of wood flooring. Include instructions for handling, storage, installation, dimensions of individual components, profiles, edge detail, finishing, protection, and maintenance.
- C. Shop Drawings: For each type of floor assembly and accessory. Include plans, elevations, sections, details, and attachments to other work. Include the following:
 - 1. Expansion provisions and trim details.
 - 2. Layout, colors, widths, and dimensions of game lines and markers.
 - 3. Location of floor inserts for athletic equipment installed through flooring assembly.

1.4. QUALITY ASSURANCE

- A. Installer Qualifications: Engage an experienced installer who has specialized in installing types of wood flooring similar to those required for this Project.
- B. Source Quality Control: Obtain flooring of each type from a single manufacturer or source to ensure a match of quality, color, pattern, and texture.

1.5. DELIVERY, STORAGE, AND HANDLING

- A. Protect wood flooring from exposure to moisture in shipment, storage, and handling. Deliver in unopened cartons or bundles and store in a dry place with adequate air circulation. Do not deliver material to building until concrete, plaster, masonry, ceramic tile, and other wet work is complete and cured to a condition of equilibrium and temperature and humidity are maintained at or near occupancy levels.

1.6. PROJECT CONDITIONS

- A. Moisture Content: At time of delivery, average moisture content of wood flooring to be 6 to 9 percent, with a maximum of 12 percent for any one piece and not more than 5 percent outside of given average range.
- B. Conditioning: Do not install wood flooring until spaces are enclosed and at approximate humidity condition planned for occupancy. Condition wood for 10 days before start of installation by placing in spaces to receive flooring and maintaining ambient temperature between 65 deg F and 75 deg F (18 deg C and 24 deg C) before, during, and after installation. Open sealed packages of wood flooring to permit natural adjustment of moisture content and allow flooring to acclimate to the room conditions.

1.7. WARRANTY

- A. Warranty: Submit a written warranty executed by Manufacturer, Installer, and Contractor, agreeing to repair or replace wood flooring that fails in materials or workmanship within the specified warranty period. Failures include, but are not limited to:
 - 1. Buckling, warping, squeaking, and loosening.
 - 2. Excessive open joints or cracks.
 - 3. Deterioration of finishes beyond normal wear.
- B. Warranty Period: 1 year from date of Substantial Completion.
- C. The warranty shall not deprive the Owner of other rights the Owner may have under other provisions of the Contract Documents and will be in addition to and run concurrent with other warranties made by the Contractor under requirements of the Contract Documents.

1.8. EXTRA MATERIAL

- A. Deliver extra material to Owner. Before installation begins, furnish not less than 0.50 percent of the quantity of each type wood flooring installed on the Project, packaged with protective covering for storage and identified with labels clearly describing contents.

PART 2 - PRODUCTS

2.1. MANUFACTURERS/SYSTEMS/PRODUCTS

- A. Manufacturers/Systems/Products: Subject to compliance with requirements, provide of the following:

1. Athletic Floor for Gymnasium:
 - a. Action Floor Systems, "Action Cush I", 7/16" Airtech II pads.
 - b. Conner, "Rezill Panel", 7/16" Multi Flex pads.
 - c. Acer, "Acer Cush II" with 7/16" EcoDin pads.
 2. Base:
 - a. Johnson molded, vented base.
 3. Vapor Retarder:
 - a. Fortifiber, "Moistop Ultra 15"
 4. Floor Sealer:
 - a. Hillyard, "Penetrating Seal #21", or as recommended by manufacturer, (2) coats.
 5. Floor Finish:
 - a. Hillyard urethane oil finish, or as recommended by manufacturer, (2) coats.
- B. Systems and/or products by other manufacturers are subject to approval prior to bidding.

2.2. WOOD STRIP/PLANK FLOORING

- A. Solid Wood Flooring: Strip solid wood flooring:
1. Species: Hard maple (acer saccharum).
 2. Grade: Maple Flooring Manufacturers Association graded "Second and Better".
 3. Matching: Tongued-and-grooved and end-matched.
 4. Back Channeling: Provide manufacturer's standard channeling on back face of each strip.
 5. Thickness: 25/32 inch.
 6. Face Width: 2-1/4 inches.
 7. Lengths: Provide system manufacturer's standard random length strips, complying with applicable grading rules.

2.3. SUBFLOORING

- A. Plywood subflooring at the gymnasium floor shall be two layers of 4' x 8' x 15/32" thick C-D Exposure 1 plywood, panel index 32/16.
- B. Plywood subflooring at the stage floor shall be two base layers of 4' x 8' x 15/32" thick C-D Exposure 1 plywood, panel index 32/16 (with one top finish layer of 4' x 8' x 3/4" thick A-C Exposure 1 plywood, panel index 32/16.)

2.4. RESILIENT PADS

- A. Resilient pads shall be manufacturer's proprietary 7/16" minimum thickness pads as required for specific floor system specified at the Gymnasium wood flooring installation.
- B. Resilient pads shall be manufacturer's proprietary 7/16" minimum thickness pads as required for specific floor system specified at the stage floor.

2.5. ACCESSORY MATERIALS

- A. Base: 3" x 4" rubber base, vented, color back.
- B. Vapor Retarder: 15 mil polyolefin sheet with manufacturer provided or recommended tape for sealing seams.
 - 1. Perm Rating: 0.02 per ASTM E-154
- C. Fasteners: Fasteners shall be as required by and as furnished by the flooring manufacturer to install the specific floor system for the specific area indicated. Minimum 2" barbed cleats or coated staples at flooring and minimum 1" staples at subflooring spaced per manufacturer's requirements.
- D. Hardwood Trim: Clear White Oak for stage front. Sizes as noted on Drawings.

PART 3 - EXECUTION

3.1. INSPECTION

- A. Examine substrates where wood flooring will be installed and conditions under which work will be performed. Do not proceed with work until unsatisfactory conditions have been corrected in manner acceptable to Installer. Slab flatness, moisture content, and ambient temperature and humidity in room shall comply with manufacturer's requirements.

3.2. PREPARATION

- A. Thoroughly clean all concrete slabs to receive wood flooring systems prior to installing vapor retarder.

3.3. INSTALLATION

- A. General: Comply with flooring manufacturer's printed instructions and recommendations, (as approved by Architect) for each specific flooring system to be installed.

- B. Vapor Retarder: Install vapor retarder over entire area to receive wood flooring. Do not install until tested moisture content in concrete slab meets requirements of flooring manufacturer. Lap joints 6" minimum at sides and 1'-0" minimum at ends. Seal all joints with pressure sensitive tape of type recommended by vapor retarder manufacturer.
- C. Install resilient pads and plywood subfloor in strict accordance with flooring manufacturer's printed instructions for each specific type of flooring system.
- D. Pattern: Lay wood flooring as follows:
 1. Gymnasium: With finish flooring strips parallel with long dimension of court.
 2. First layer of plywood subflooring perpendicular to finish flooring.
 3. Second layer of plywood subflooring at 45 degree angle to first layer.
- E. Expansion Space: Provide expansion space at walls and other obstructions and terminations of flooring of not less than 1 ½" inch unless otherwise indicated on drawings. Install vented base over expansion space.
- F. Solid Wood Flooring Installation: Blind-nail flooring to substrate in accordance with flooring manufacturer's instructions using barbed cleats.

3.4. SANDING AND FINISHING

- A. Machine sand installed unfinished flooring to remove offsets and non-level conditions, ridges, cups, and sanding machine marks which would be visually noticeable after finishing. Use 3 grades of sandpaper, ending with 00 grade. Vacuum clean and immediately apply finish. Do not permit traffic on floor after sanding and until finish is completed. Cover sanded floor with building paper to provide access for application of first finish coats.
- B. Apply floor sealer (2 coats) and apply floor finish (2 coats) to gymnasium floor in accordance with manufacturer's instructions. Machine buff with steel wool between coats, in-the-wet where recommended by manufacturer.
- C. Game-Line and Marker Paint: Apply game-line and marker paint between final seal coat and first finish coat according to paint manufacturer's written instructions.
 1. Mask flooring at game lines and markers, and apply paint to produce lines and markers with sharp edges.
 2. Excessive wear of finishes can result in areas where game-line and marker paint buildup is heavy. Game lines should not overlap. Where game lines cross, minor game line should break at intersection.
 3. Where game lines cross, break minor game line at intersection; do not overlap lines.
 4. Apply game lines and markers in widths and colors according to requirements indicated on Drawings
 5. Apply finish coats after game-line and marker paint is fully cured.

3.5. BASE INSTALLATION

- A. Install vent cove base anchored to walls with base cement.
- B. Use pre-molded outside corners and mitered inside corners.

3.6. PROTECTION

- A. Protect installed unfinished and prefinished wood flooring during remainder of construction period with heavy kraft paper or other suitable covering to prevent damage or deterioration. Do not use plastic sheet or film that could cause condensation.
- B. Do not cover site-finished floors with kraft paper, rugs or any other material until finish reaches full cure, minimum ten (10) days.

END OF SECTION 096466

SECTION 096513 - RESILIENT BASE AND ACCESSORIES

PART 1 - GENERAL

1.1 RELATED DOCUMENTS

- A. Drawings and general provisions of the Contract, including General and Supplementary Conditions and Division 01 Specification Sections, apply to this Section.

1.2 SUMMARY

- A. Section Includes:
 - 1. Resilient base.
 - 2. Resilient stair accessories.
 - 3. Resilient molding accessories.

1.3 SUBMITTALS

- A. Product Data: For each type of product indicated.
- B. Samples for Color Selection: For each type of product indicated.

1.4 QUALITY ASSURANCE

- A. Fire-Test-Response Characteristics: As determined by testing identical products according to ASTM E 648 or NFPA 253 by a qualified testing agency.
 - 1. Critical Radiant Flux Classification: Class I, not less than 0.45 W/sq. cm.

1.5 DELIVERY, STORAGE, AND HANDLING

- A. Store resilient products and installation materials in dry spaces protected from the weather, with ambient temperatures maintained within range recommended by manufacturer, but not less than 50 deg F (10 deg C) or more than 90 deg F (32 deg C).

1.6 PROJECT CONDITIONS

- A. Maintain ambient temperatures within range recommended by manufacturer, but not less than 70 deg F (21 deg C) or more than 95 deg F (35 deg C), in spaces to receive resilient products during the following time periods:
 - 1. 48 hours before installation.
 - 2. During installation.
 - 3. 48 hours after installation.

- B. Until Substantial Completion, maintain ambient temperatures within range recommended by manufacturer, but not less than 55 deg F (13 deg C) or more than 95 deg F (35 deg C).
- C. Install resilient products after other finishing operations, including painting, have been completed.

1.7 EXTRA MATERIALS

- A. Furnish extra materials that match products installed and that are packaged with protective covering for storage and identified with labels describing contents.
 - 1. Furnish not less than 10 linear feet (3 linear m) for every 500 linear feet (150 linear m) or fraction thereof, of each type, color, pattern, and size of resilient product installed.

PART 2 - PRODUCTS

2.1 RESILIENT BASE

- A. Resilient Base:
 - 1. Manufacturers: Subject to compliance with requirements, provide products by one of the following:
 - a. Burke Mercer Flooring Products; Division of Burke Industries, Inc.
 - b. Flexco, Inc.
 - c. Johnsonite.
 - d. Roppe Corporation, USA.
 - 2. Products by other Manufacturers are subject to approval by Architect prior to bidding.
- B. Resilient Base Standard: ASTM F 1861.
 - 1. Material Requirement: Type TS (rubber, vulcanized thermoset).
 - 2. Manufacturing Method: Group I (solid, homogeneous).
 - 3. Style: Standard Cove (base with toe).
- C. Minimum Thickness: 0.125 inch (3.2 mm).
- D. Height: As indicated on Drawings.
- E. Lengths: Cut lengths 48 inches (1219 mm) long or coils in manufacturer's standard length.
- F. Outside Corners: Job formed.
- G. Inside Corners: Job formed.
- H. Finish: As selected by Architect from manufacturer's full range.

- I. Colors and Patterns: As selected by Architect from manufacturer's full range. A maximum of four colors will be selected.

2.2 RESILIENT STAIR ACCESSORIES

A. Resilient Stair Treads:

- 1. Manufacturers: Subject to compliance with requirements, provide products by one of the following:
 - a. Burke Mercer Flooring Products; Division of Burke Industries, Inc.
 - b. Flexco, Inc.
 - c. Johnsonite.
 - d. Roppe Corporation, USA.
- 2. Products by other Manufacturers are subject to approval by Architect prior to bidding.

B. Resilient Stair Treads Standard: ASTM F 2169.

- 1. Material Requirement: Type TS (rubber, vulcanized thermoset).
- 2. Surface Design:
 - a. Class 2, Pattern: Raised-square design.
- 3. Manufacturing Method: Group 2, tread with contrasting color for the visually impaired.

C. Nosing Style: Square, adjustable to cover angles between 60 and 90 degrees.

D. Nosing Height: 1-1/2 inches (38 mm) minimum.

E. Thickness: 1/4 inch (6 mm) and tapered to back edge.

F. Size: Lengths and depths to fit each stair tread in one piece.

G. Risers: Smooth, flat, toeless, height and length to cover risers; produced by same manufacturer as treads and recommended by manufacturer for installation with treads.

- 1. Thickness: 0.125 inch (3.2 mm).

H. Wall Skirting: Smooth, flat, and toeless with height as required to extend from tread and clear tread nosings by not less than 3 inches.

I. Colors and Patterns: As selected by Architect from manufacturer's full range. One color only will be selected.

2.3 RESILIENT MOLDING ACCESSORY

A. Resilient Molding Accessory:

- 1. Manufacturers: Subject to compliance with requirements, provide products by one of the following:

- a. Burke Mercer Flooring Products; Division of Burke Industries, Inc.
- b. Flexco, Inc.
- c. Johnsonite.
- d. Roppe Corporation, USA.

2. Products by other Manufacturers are subject to approval by Architect prior to bidding.

- B. Description: Carpet Edge for glue-down applications, Nosing for carpet, Nosing for resilient floor covering, Reducer strip for resilient floor covering, Joiner for tile and carpet, Transition strips, etc.
- C. Material: Rubber.
- D. Profile and Dimensions: As indicated.
- E. Colors and Patterns: As selected by Architect from manufacturer's full range.

2.4 INSTALLATION MATERIALS

- A. Trowelable Leveling and Patching Compounds: Latex-modified, portland cement based or blended hydraulic-cement-based formulation provided or approved by manufacturer for applications indicated.
- B. Adhesives: Water-resistant type recommended by manufacturer to suit resilient products and substrate conditions indicated.
 - 1. Use adhesives that comply with the following limits for VOC content when calculated according to 40 CFR 59, Subpart D (EPA Method 24):
 - a. Cove Base Adhesives: Not more than 50 g/L.
 - b. Rubber Floor Adhesives: Not more than 60 g/L.
- C. Metal Edge Strips: Extruded aluminum with mill finish of width shown, of height required to protect exposed edges of tiles, and in maximum available lengths to minimize running joints.
- D. Floor Polish: Provide protective liquid floor polish products as recommended by resilient stair tread manufacturer.
- E. Stair-Tread-Nose Filler: Two-part epoxy compound recommended by resilient tread manufacturer to fill nosing substrates that do not conform to tread contours.

PART 3 - EXECUTION

3.1 EXAMINATION

- A. Examine substrates, with Installer present, for compliance with requirements for maximum moisture content and other conditions affecting performance of the Work.

- B. Verify that finishes of substrates comply with tolerances and other requirements specified in other Sections and that substrates are free of cracks, ridges, depressions, scale, and foreign deposits that might interfere with adhesion of resilient products.
- C. Proceed with installation only after unsatisfactory conditions have been corrected.

3.2 PREPARATION

- A. Prepare substrates according to manufacturer's written instructions to ensure adhesion of resilient products.
- B. Concrete Substrates for Resilient Base and Accessories: Prepare according to ASTM F 710.
 - 1. Verify that substrates are dry and free of curing compounds, sealers, and hardeners.
 - 2. Remove substrate coatings and other substances that are incompatible with adhesives and that contain soap, wax, oil, or silicone, using mechanical methods recommended by manufacturer. Do not use solvents.
 - 3. Alkalinity and Adhesion Testing: Perform tests recommended by manufacturer.
 - 4. Moisture Testing: Perform tests recommended by manufacturer and as follows. Proceed with installation only after substrates pass testing.
 - a. Perform anhydrous calcium chloride test, ASTM F 1869. Proceed with installation only after substrates have maximum moisture-vapor-emission rate of 3 lb of water/1000 sq. ft. (1.36 kg of water/92.9 sq. m) in 24 hours.
 - b. Perform relative humidity test using in situ probes, ASTM F 2170. Proceed with installation only after substrates have maximum 75 percent relative humidity level measurement.
- C. Fill cracks, holes, and depressions in substrates with trowelable leveling and patching compound and remove bumps and ridges to produce a uniform and smooth substrate.
- D. Do not install resilient products until they are same temperature as the space where they are to be installed.
 - 1. Move resilient products and installation materials into spaces where they will be installed at least 48 hours in advance of installation.
- E. Sweep and vacuum clean substrates to be covered by resilient products immediately before installation.

3.3 RESILIENT BASE INSTALLATION

- A. Comply with manufacturer's written instructions for installing resilient base.
- B. Apply resilient base to walls, columns, pilasters, casework and cabinets in toe spaces, and other permanent fixtures in rooms and areas where base is required.
- C. Install resilient base in lengths as long as practicable without gaps at seams and with tops of adjacent pieces aligned.

- D. Tightly adhere resilient base to substrate throughout length of each piece, with base in continuous contact with horizontal and vertical substrates.
- E. Do not stretch resilient base during installation.
- F. On masonry surfaces or other similar irregular substrates, fill voids along top edge of resilient base with manufacturer's recommended adhesive filler material.
- G. Job-Formed Corners:
 - 1. Outside Corners: Use straight pieces of maximum lengths possible. Form without producing discoloration (whitening) at bends.
 - 2. Inside Corners: Use straight pieces of maximum lengths possible.

3.4 RESILIENT ACCESSORY INSTALLATION

- A. Comply with manufacturer's written instructions for installing resilient accessories.
- B. Resilient Stair Accessories:
 - 1. Use stair-tread-nose filler to fill nosing substrates that do not conform to tread contours.
 - 2. Tightly adhere to substrates throughout length of each piece.
 - 3. For treads installed as separate, equal-length units, install to produce a flush joint between units.
- C. Resilient Molding Accessories: Butt to adjacent materials and tightly adhere to substrates throughout length of each piece. Install reducer strips at edges of carpet and resilient floor covering that would otherwise be exposed, and joiners between dis-similar materials whether or not specifically indicated on plans.

3.5 CLEANING AND PROTECTION

- A. Comply with manufacturer's written instructions for cleaning and protection of resilient products.
- B. Perform the following operations immediately after completing resilient product installation:
 - 1. Remove adhesive and other blemishes from exposed surfaces.
 - 2. Sweep and vacuum surfaces thoroughly.
 - 3. Damp-mop surfaces to remove marks and soil.
- C. Protect resilient products from mars, marks, indentations, and other damage from construction operations and placement of equipment and fixtures during remainder of construction period.
- D. Floor Polish: Remove soil, visible adhesive, and surface blemishes from resilient stair treads before applying liquid floor polish.
 - 1. Apply one coat.
- E. Cover resilient products until Substantial Completion.

END OF SECTION 096513

THIS PAGE INTENTIONALLY BLANK

SECTION 096516 - RESILIENT SHEET FLOORING

PART 1 - GENERAL

1.1 RELATED DOCUMENTS

- A. Drawings and general provisions of the Contract, including General and Supplementary Conditions and Division 01 Specification Sections, apply to this Section.

1.2 SUMMARY

- A. Section Includes:
 - 1. Resilient rigid vinyl sheet kitchen flooring.
 - 2. Unbacked sheet vinyl flooring.

1.3 SUBMITTALS

- A. Product Data: For each type of product indicated.
- B. Samples for Color Selection: For each type of floor covering indicated.
- C. Qualification Data: For qualified Installer.

1.4 QUALITY ASSURANCE

- A. Installer Qualifications: A qualified installer who employs workers for this Project who are competent in techniques required by manufacturer for floor covering installation and seaming methods indicated.
- B. Fire-Test-Response Characteristics: As determined by testing identical products according to ASTM E 648 or NFPA 253 by a qualified testing agency.
 - 1. Critical Radiant Flux Classification: Class I, not less than 0.45 W/sq. cm.

1.5 DELIVERY, STORAGE, AND HANDLING

- A. Store floor coverings and installation materials in dry spaces protected from the weather, with ambient temperatures maintained within range recommended by manufacturer, but not less than 50 deg F (10 deg C) or more than 90 deg F (32 deg C). Store rolls upright.

1.6 PROJECT CONDITIONS

- A. Maintain ambient temperatures within range recommended by manufacturer, but not less than 70 deg F (21 deg C) or more than 85 deg F (29 deg C), in spaces to receive floor coverings during the following time periods:
 - 1. 48 hours before installation.
 - 2. During installation.
 - 3. 48 hours after installation.
- B. Until Substantial Completion, maintain ambient temperatures within range recommended by manufacturer, but not less than 55 deg F (13 deg C) or more than 95 deg F (35 deg C).
- C. Close spaces to traffic during floor covering installation.
- D. Close spaces to traffic for 48 hours after floor covering installation.
- E. Install floor coverings after other finishing operations, including painting, have been completed.

1.7 EXTRA MATERIALS

- A. Furnish extra materials that match products installed and that are packaged with protective covering for storage and identified with labels describing contents.
 - 1. Floor Covering: Furnish quantity not less than 10 linear feet (3 linear m) for every 500 linear feet (150 linear m) or fraction thereof, in roll form and in full roll width, and in full sheet size, for each color, pattern, and type of floor covering installed.

PART 2 - PRODUCTS

2.1 RESILIENT RIGID VINYL SHEET KITCHEN FLOORING.

- A. Manufacturers: Subject to compliance with requirements, provide products by:
 - 1. Oscoda Plastics, Inc. Protect-All Commercial Flooring
- B. Products by other manufacturers are subject to approval by architect prior to bidding.
- C. Resilient rigid vinyl sheet.
 - 1. Description: Resilient Rigid Vinyl Sheet Flooring.
 - 2. Width: 60 inches
 - 3. Length: 96 inches
 - 4. Thickness: 1/4 inch.
 - 5. Pattern and Color: As selected by Architect from manufacturer's standard patterns and colors, (1) color maximum.
 - 6. Adhesive: Manufacturer's 2-part epoxy flooring adhesive.
 - 7. Heat Welding Rod: Manufacturer's rapid weld in matching floor color.
 - 8. Finish: Protect All E-6100 sealant.

9. Extend resilient sheet cove base 6 inches up wall.
10. Integral-Flash-Cove-Base Accessories:
 - a. Cove Strip: 1-inch (25-mm) radius or flooring manufacturer's standard.
 - b. Cap Strip: Stainless steel or aluminum cove base cap by manufacturer.
 - c. Corners: Metal inside and outside corners and end stops provided or approved by manufacturer.
11. Manufacturer provided stainless steel drain rings, corner guards, and transition strips.

2.2 UNBACKED SHEET VINYL FLOORING

- A. Manufacturer / Product: Mannington Mills, Inc., Assurance II (Slip-resistant)
- B. Product Standard: ASTM F 1913
- C. Thickness: 0.080 inch.
- D. Wearing Surface: Non-slip.
- E. Sheet Width: 6 feet.
- F. Seamless Installation Method: Heat welded.
- G. Colors and Patterns: As selected by Architect from manufacturer's full range. (2) colors maximum.

2.3 INSTALLATION MATERIALS

- B. Trowelable Leveling and Patching Compounds: Latex-modified, portland cement based or blended hydraulic-cement-based formulation provided or approved by manufacturer for applications indicated.
- C. Adhesives: Water-resistant type recommended by manufacturer to suit floor covering and substrate conditions indicated.
- D. Seamless-Installation Accessories:
 1. Heat-Welding Bead: Manufacturer's solid-strand product for heat welding seams.
 - a. Color: Match floor covering.
- E. Floor Polish: Provide protective liquid floor polish products as recommended by manufacturer.

PART 3 - EXECUTION

3.1 EXAMINATION

- A. Examine substrates, with Installer present, for compliance with requirements for maximum moisture content and other conditions affecting performance of the Work.
- B. Verify that finishes of substrates comply with tolerances and other requirements specified in other Sections and that substrates are free of cracks, ridges, depressions, scale, and foreign deposits that might interfere with adhesion of floor coverings.

- C. Proceed with installation only after unsatisfactory conditions have been corrected.

3.2 PREPARATION

- A. Prepare substrates according to manufacturer's written instructions to ensure adhesion of floor coverings.
- B. Concrete Substrates: Prepare according to ASTM F 710.
 - 1. Verify that substrates are dry and free of curing compounds, sealers, and hardeners.
 - 2. Remove substrate coatings and other substances that are incompatible with adhesives and that contain soap, wax, oil, or silicone, using mechanical methods recommended by manufacturer. Do not use solvents.
 - 3. Alkalinity and Adhesion Testing: Perform tests recommended by manufacturer. Proceed with installation only after substrates pass testing.
 - 4. Moisture Testing: Perform tests recommended by manufacturer and as follows. Proceed with installation only after substrates pass testing.
 - a. Perform anhydrous calcium chloride test, ASTM F 1869. Proceed with installation only after substrates have maximum moisture-vapor-emission rate of 3 lb of water/1000 sq. ft. (1.36 kg of water/92.9 sq. m) in 24 hours.
 - b. Perform relative humidity test using in situ probes, ASTM F 2170. Proceed with installation only after substrates have a maximum 75 percent relative humidity level measurement.
- C. Fill cracks, holes, and depressions in substrates with trowelable leveling and patching compound and remove bumps and ridges to produce a uniform and smooth substrate.
- D. Do not install floor coverings until they are same temperature as space where they are to be installed.
 - 1. Move floor coverings and installation materials into spaces where they will be installed at least 48 hours in advance of installation.
- E. Sweep and vacuum clean substrates to be covered by floor coverings immediately before installation.

3.3 FLOOR COVERING INSTALLATION

- A. Comply with manufacturer's written instructions for installing floor coverings.
- B. Unroll floor coverings and allow them to stabilize before cutting and fitting.
- C. Lay out floor coverings as follows:
 - 1. Maintain uniformity of floor covering direction.
 - 2. Minimize number of seams; place seams in inconspicuous and low-traffic areas, at least 6 inches (152 mm) away from parallel joints in floor covering substrates.
 - 3. Match edges of floor coverings for color shading at seams.
 - 4. Avoid cross seams.

- D. Scribe and cut floor coverings to butt neatly and tightly to vertical surfaces, permanent fixtures, and built-in furniture including cabinets, pipes, outlets, and door frames.
- E. Extend floor coverings into toe spaces, door reveals, closets, and similar openings.
- F. Maintain reference markers, holes, or openings that are in place or marked for future cutting by repeating on floor coverings as marked on substrates. Use chalk or other nonpermanent marking device.
- G. Install floor coverings on covers for telephone and electrical ducts and similar items in installation areas. Maintain overall continuity of color and pattern between pieces of floor coverings installed on covers and adjoining floor covering. Tightly adhere floor covering edges to substrates that abut covers and to cover perimeters.
- H. Adhere floor coverings to substrates using a full spread of adhesive applied to substrate to produce a completed installation without open cracks, voids, raising and puckering at joints, telegraphing of adhesive spreader marks, and other surface imperfections.
- I. Seamless Installation:
 - 1. Heat-Welded Seams: Comply with ASTM F 1516. Rout joints and use welding bead to permanently fuse sections into a seamless floor covering. Prepare, weld, and finish seams to produce surfaces flush with adjoining floor covering surfaces.
- J. Integral Cove Base:
 - 1. At rigid kitchen flooring, install integral cove base per manufacturer's instructions.

3.4 CLEANING AND PROTECTION

- A. Comply with manufacturer's written instructions for cleaning and protection of floor coverings.
- B. Perform the following operations immediately after completing floor covering installation:
 - 1. Remove adhesive and other blemishes from floor covering surfaces.
 - 2. Sweep and vacuum floor coverings thoroughly.
 - 3. Damp-mop floor coverings to remove marks and soil.
- C. Protect floor coverings from mars, marks, indentations, and other damage from construction operations and placement of equipment and fixtures during remainder of construction period.
- D. Floor Polish: Remove soil, visible adhesive, and surface blemishes from floor covering before applying liquid floor polish per manufacturer's recommendations at products where required.
- E. Cover floor coverings until Substantial Completion.

END OF SECTION 096516

THIS PAGE INTENTIONALLY BLANK

SECTION 096519 - RESILIENT TILE FLOORING

PART 1 - GENERAL

1.1 RELATED DOCUMENTS

- A. Drawings and general provisions of the Contract, including General and Supplementary Conditions and Division 01 Specification Sections, apply to this Section.

1.2 SUMMARY

- A. Section Includes:
 - 1. VCT, vinyl composition floor tile.

1.3 SUBMITTALS

- A. Product Data: For each type of product indicated.
- B. Samples for Color Selection: For each type of floor tile indicated.
- C. Qualification Data: For qualified Installer.
- D. Description of proposed moisture content testing procedure.

1.4 QUALITY ASSURANCE

- A. Installer Qualifications: A qualified installer who employs workers for this Project who are competent in techniques required by manufacturer for floor tile installation indicated.
- B. Fire-Test-Response Characteristics: As determined by testing identical products according to ASTM E 648 or NFPA 253 by a qualified testing agency.
 - 1. Critical Radiant Flux Classification: Class I, not less than 0.45 W/sq. cm.
- C. Perform concrete slab moisture testing per Paragraph 3.2.B.

1.5 DELIVERY, STORAGE, AND HANDLING

- A. Store floor tile and installation materials in dry spaces protected from the weather, with ambient temperatures maintained within range recommended by manufacturer, but not less than 50 deg F (10 deg C) or more than 90 deg F (32 deg C). Store floor tiles on flat surfaces.

1.6 PROJECT CONDITIONS

- A. Maintain ambient temperatures within range recommended by manufacturer, but not less than 70 deg F (21 deg C) or more than 95 deg F (35 deg C) in spaces to receive floor tile during the following time periods:
 - 1. 48 hours before installation.
 - 2. During installation.
 - 3. 48 hours after installation.
- B. Until Substantial Completion, maintain ambient temperatures within range recommended by manufacturer, but not less than 55 deg F (13 deg C) or more than 95 deg F (35 deg C).
- C. Close spaces to traffic during floor tile installation.
- D. Close spaces to traffic for 48 hours after floor tile installation.
- E. Install floor tile after other finishing operations, including painting, have been completed.

1.7 EXTRA MATERIALS

- A. Furnish extra materials that match products installed and that are packaged with protective covering for storage and identified with labels describing contents.
 - 1. Floor Tile: Furnish 1 box of each type, color, and pattern of floor tile installed.

PART 2 - PRODUCTS

2.1 VINYL COMPOSITION FLOOR TILE

- A. Manufacturers: Subject to compliance with requirements, provide products by one of the following:
 - 1. Armstrong World Industries, Inc.
 - 2. Mannington Mills, Inc.
 - 3. Tarkett, Inc.
- B. Tile Standard: ASTM F 1066, Class 2, through-pattern tile.
- C. Wearing Surface: Smooth.
- D. Thickness: 0.125 inch (3.2 mm).
- E. Size: 12 by 12 inches (305 by 305 mm).
- F. Colors and Patterns: As selected by Architect from manufacturer's full range including up to 20 percent premium price colors and patterns. A maximum of (2) premium price colors / patterns will be selected.

2.2 INSTALLATION MATERIALS

- A. Trowelable Leveling and Patching Compounds: Latex-modified, portland cement based or blended hydraulic-cement-based formulation provided or approved by manufacturer for applications indicated.
- B. Adhesives: Water-resistant type recommended by manufacturer to suit floor tile and substrate conditions indicated.
- C. Floor Polish: Provide protective liquid floor polish products as recommended by manufacturer and / or of type requested by Owner.

PART 3 - EXECUTION

3.1 EXAMINATION

- A. Examine substrates, with Installer present, for compliance with requirements for maximum moisture content and other conditions affecting performance of the Work.
- B. Verify that finishes of substrates comply with tolerances and other requirements specified in other Sections and that substrates are free of cracks, ridges, depressions, scale, and foreign deposits that might interfere with adhesion of floor tile.
- C. Proceed with installation only after unsatisfactory conditions have been corrected.

3.2 PREPARATION

- A. Prepare substrates according to manufacturer's written instructions to ensure adhesion of resilient products.
- B. Concrete Substrates: Prepare according to ASTM F 710.
 - 1. Verify that substrates are dry and free of curing compounds, sealers, and hardeners.
 - 2. Remove substrate coatings and other substances that are incompatible with adhesives and that contain soap, wax, oil, or silicone, using mechanical methods recommended by manufacturer. Do not use solvents.
 - 3. Alkalinity and Adhesion Testing: Perform tests recommended by manufacturer. Proceed with installation only after substrates pass testing.
 - 4. Moisture Testing: Perform tests recommended by manufacturer and as follows. Proceed with installation only after substrates pass testing.
 - a. Perform anhydrous calcium chloride test, ASTM F 1869. Proceed with installation only after substrates have maximum moisture-vapor-emission rate of 3 lb of water/1000 sq. ft. (1.36 kg of water/92.9 sq. m) in 24 hours.
 - b. Perform relative humidity test using in situ probes, ASTM F 2170. Proceed with installation only after substrates have a maximum 75 percent relative humidity level measurement.
 - c. Alternative moisture testing procedures are subject to review and approval of the Architect.

- C. Fill cracks, holes, and depressions in substrates with trowelable leveling and patching compound and remove bumps and ridges to produce a uniform and smooth substrate.
- D. Do not install floor tiles until they are same temperature as space where they are to be installed.
 - 1. Move resilient products and installation materials into spaces where they will be installed at least 48 hours in advance of installation.
- E. Sweep and vacuum clean substrates to be covered by resilient products immediately before installation.

3.3 FLOOR TILE INSTALLATION

- A. Comply with manufacturer's written instructions for installing floor tile.
- B. Lay out floor tiles from center marks established with principal walls, discounting minor offsets, so tiles at opposite edges of room are of equal width. Adjust as necessary to avoid using cut widths that equal less than one-half tile at perimeter.
 - 1. Lay tiles square with room axis and in pattern indicated, where applicable.
- C. Match floor tiles for color and pattern by selecting tiles from cartons in the same sequence as manufactured and packaged, if so numbered. Discard broken, cracked, chipped, or deformed tiles.
 - 1. Lay VCT tiles with grain direction alternating in adjacent tiles (basket-weave pattern) and in pattern of colors and sizes indicated, where applicable.
- D. Scribe, cut, and fit floor tiles to butt neatly and tightly to vertical surfaces and permanent fixtures including built-in furniture, cabinets, pipes, outlets, and door frames.
- E. Extend floor tiles into toe spaces, knee spaces, door reveals, closets, and similar openings. Extend floor tiles to center of door openings.
- F. Maintain reference markers, holes, and openings that are in place or marked for future cutting by repeating on floor tiles as marked on substrates. Use chalk or other nonpermanent, nonstaining marking device.
- G. Install floor tiles on covers for telephone and electrical ducts, building expansion-joint covers, and similar items in finished floor areas. Maintain overall continuity of color and pattern between pieces of tile installed on covers and adjoining tiles. Tightly adhere tile edges to substrates that abut covers and to cover perimeters.
- H. Adhere floor tiles to flooring substrates using a full spread of adhesive applied to substrate to produce a completed installation without open cracks, voids, raising and puckering at joints, telegraphing of adhesive spreader marks, and other surface imperfections.

3.4 CLEANING AND PROTECTION

- A. Comply with manufacturer's written instructions for cleaning and protection of floor tile.

- B. Perform the following operations immediately after completing floor tile installation:
 - 1. Remove adhesive and other blemishes from exposed surfaces.
 - 2. Sweep and vacuum surfaces thoroughly.
 - 3. Damp-mop surfaces to remove marks and soil.
- C. Protect floor tile products from mars, marks, indentations, and other damage from construction operations and placement of equipment and fixtures during remainder of construction period.
- D. Floor Polish: Remove soil, visible adhesive, and surface blemishes from floor tile surfaces before applying liquid floor polish.
 - 1. Apply four coats. Coordinate floor polish product and polishing procedures with Owner.
- E. Cover floor tile until Substantial Completion.

END OF SECTION 096519

THIS PAGE INTENTIONALLY BLANK

SECTION 096816 – CARPETING

PART 1 – GENERAL

1.1. RELATED DOCUMENTS

- A. Drawings and general provisions of Contract, including General and Supplementary Conditions and Division 1 Specification Sections, apply to this Section.

1.2. SUMMARY

- A. This Section includes carpet tiles, accessories, and installation.

1.3. SUBMITTALS

- A. General: Submit the following in accordance with Conditions of Contract and Division 1 Specification Sections.
- B. Product data for each type of carpet material and installation accessory required. Submit written data on physical characteristics, durability, resistance to fading, and flame resistance characteristics.
- C. Samples for selection purposes in manufacturer's standard size, showing full range of color, texture, and pattern variations expected. Prepare samples from same material to be used for the Work. Submit the following:
 - 1. Sample book/binder showing each type of carpet material color and pattern available.
 - 2. 12-inch long samples of each type exposed edge stripping and accessory item.

1.4. WARRANTY

- A. Contractor shall submit the carpet manufacturer's standard warranty which is signed by a corporate officer as an official document, covering the following specific items:
 - 1. Lifetime Commercial Limited
 - 2. Wear - 10 years minimum
 - 3. Stain – lifetime

1.5. QUALITY ASSURANCE

- A. Carpet Surface Burning Characteristics: Provide carpet identical to that tested for the following fire performance characteristics, per test method indicated below, by UL or other testing and inspecting organizations acceptable to authorities having jurisdiction. Identify carpet with appropriate markings of applicable testing and inspecting organization.

1. Flooring radiant panel test – ASRM E-648-78 and /or NFPA 253. Carpet shall have a minimum critical radiant flux of (0.22) watts per square centimeter.
2. Methenamine tablet test “Standards for the surface flammability of carpets.”

1.6. DELIVERY, STORAGE, AND HANDLING

- A. Deliver materials to project site in original factory wrappings and containers, labeled with identification of manufacturer, brand name, and lot number.
- B. Store materials in original undamaged packages and containers, inside well-ventilated area protected from weather, moisture, soilage, extreme temperatures, and humidity. Lay flat, blocked off ground. Maintain minimum temperature of 68 deg F (20 deg C) at least three days prior to and during installation in area where materials are stored.

1.7. PROJECT CONDITIONS

- A. Substrate Conditions: No condensation within 48 hours on underside of 4-foot by 4-foot polyethylene sheet, fully taped at perimeter to substrate.
- B. Substrate Conditions: pH or 9 or less when substrate wetted with potable water and pHDrion paper applied.

1.8. EXTRA MATERIALS

- A. Deliver extra materials to Owner. Furnish extra materials matching products installed as described below, packaged with protective covering for storage and identified with labels describing contents.
 1. Carpet Tiles: Before installation begins, furnish quantity of each carpet tile material/color/pattern equal to 5 percent of amount installed.

1.9. COLORS

- A. A maximum of two different colors from the manufacturer's standard color selections will be used, and a maximum of three different accent colors from the manufacturer's full range will be selected for this project.

PART 2 - PRODUCTS

2.1. CARPET MANUFACTURERS / PRODUCTS

- A. Manufacturers/Products: Subject to compliance with requirements, provide the following product and manufacturer.
 1. Carpet Tile / Field Tile: (90% of specified carpet quantity)
 - a. Shaw, Diffuse and Disperse Tile 59575.

- b. Mannington “Mainboard” – Infinity Modular.
- c. Mohawk, Venturesome BT356 QS Tile.

1. Color Selections and Installation Pattern:

- a. Up to (2) field tile colors shall be selected for field carpet throughout the building. Only (1) color shall be utilized in each room. A minimum of 90% of the carpet per room will be the field carpet. The remaining 10% shall be the accent carpet, up to (3) colors selected and installed in a random fashion per direction of the Architect.

2. Carpet Tile / Accent Tile: (10% of specified carpet quantity)

- a. Shaw “Color Frame” 5T081
- b. Mannington “Color Anchor”
- c. Mohawk “Color Beat” GT160

1. Color Selections and Installation Pattern:

- a. Up to (3) accent tile colors shall be selected and installed for accent carpet throughout the building. Up to 10% of tile in each room shall be accent carpet installed in a random fashion per direction of the Architect.

3. Entry/Walk-Off Carpet Tile:

- a. Shaw, Bon Jour II Tile 5T032, Steppin Out.
- b. Equivalent products by Patcraft and Mohawk are also approved.

4. Other products and other manufacturers are subject to approval prior to bidding.

B. Carpet Tile Specifications: Carpet Tile shall conform to the following minimum specifications:

- 1. Construction – Multi-level pattern loop, tufted pattern loop
- 2. Stitches per inch – 9 minimum
- 3. Dye Method – Solution dyed Nylon, Eco Solution Q Nylon, Colorstrand SD Nylon
- 4. Density – 6,200 minimum
- 5. Flammability – ASTM E – 648 Class I
- 6. Smoke density - Less than 450
- 7. Size – 24” x 24”
- 8. Protective Treatments – soil inhibitor
- 9. Primary Backing – Synthetic
- 10. Secondary Backing – EcoWorx Tile, EcoFlex ICT

C. Walk-Off Carpet Tile Specifications:

- 1. Construction – Needlebond rib or equivalent
- 2. Fiber – Polyester
- 3. Dye Method – Solution Dyed

4. Size – 24” x 24”
5. Backing - EcoWorx

2.2. ACCESSORIES

- A. Carpet Edge Guard: Extruded or molded heavy-duty vinyl or rubber of size and profile indicated; minimum 2-inch-wide anchorage flange; manufacturer's standard colors. A maximum of one color will be selected.
- B. Carpet Adhesive: Water resistant and non-staining as recommended by carpet tile manufacturer to comply with flammability requirements for installed carpet.

PART 3 - EXECUTION

3.1. PREPARATION

- A. Clear away debris and scrape up cementitious deposits from concrete surfaces to receive carpet; apply sealer to prevent dusting.
- B. Patch holes and level concrete slabs to a smooth surface.

3.2. INSTALLATION

- A. Comply with manufacturer's requirements and instructions for carpet tile installation and tile layout within a room or space.
- B. Install carpet tile after installation of fixed cabinets and shelving, cutting carpet around such items. Do not extend carpet under fixed cabinets, etc.
- C. Extend carpet tile under removable flanges and furnishings and into alcoves and closets of each space.
- D. Provide cutouts where required, and bind cut edges where not concealed by protective edge guards or overlapping flanges.
- E. Install carpet edge guard where edge of carpet is exposed; anchor guards to substrate.
- F. Install carpet tile in 1/4 turn pattern.
- G. Install carpet tile by trimming edges and butting cuts tight to adjacent tiles and surfaces.
- H. Fit sections of carpet tile prior to application of adhesive. Trim edges and butt cuts with seaming cement.
- I. Apply adhesive uniformly to substrate in accordance with manufacturer's instructions. Butt edges tight to form seams without gaps. Roll entire area lightly to eliminate air pockets and ensure uniform bond.

J. Fill recesses in floor electrical / data outlet covers with carpet tile cut to fit.

3.3. CLEANING

A. Remove adhesive from carpet surface with manufacturer's recommended cleaning agent.

B. Remove and dispose of debris and unusable scraps. Vacuum with commercial machine with face-beater element. Remove soil. Replace carpet where soil cannot be removed. Remove protruding face yarn.

C. Vacuum carpet.

3.4. PROTECTION

A. Provide final protection and maintain conditions, in a manner acceptable to manufacturer and installer, to ensure carpet tile is not damaged or deteriorated at time of Substantial Completion.

END OF SECTION 096816

THIS PAGE INTENTIONALLY BLANK

SECTION 097200 – DIGITALLY PRINTED VINYL WALLCOVERING MURALS

PART 1 – GENERAL

1.1. RELATED DOCUMENTS

- A. Drawings and general provisions of Contract, including General and Supplementary Conditions and Division 1 Specification Sections, apply to this Section.

1.2. SUMMARY

- A. Creation and installation of digitally printed vinyl wallcovering.
- B. Related Sections
 - 1. Section 092900 Gypsum Board: Wall Substrates.
 - 2. Section 099123 Painting: Preparation and priming of substrate surfaces.

1.3. REFERENCES

- A. American Society for Testing and Materials (ASTM):
 - 1. E84, Test Method for Surface Burning Characteristics of Building Materials.
- B. Wallcovering Association (WA):
 - 1. WA-1-1-2011, Quality Standard for Polymer Coated Fabric Wallcovering.
- C. Federal Specification (FedSpec):
 - 1. CCC-W-408A, Wallcovering, Vinyl Coated.
- D. Underwriters Laboratory, Inc. (UL):
 - 1. UL 723, Test for Surface Burning Characteristics of Building Materials.
- E. National Fire Protection Agency (NFPA)
 - 1. NFPA 101, Life Safety Code
 - 2. NFPA 286, Standard Methods of Fire Tests for Evaluating Contribution of Wall and ceiling Interior Finish to Room Fire Growth.
 - 3. CAN/ULC-S102, Test for Surface Burning Characteristics of Building Materials and Assemblies.

1.4. SUBMITTALS

- A. Submit one Color Proof for approval prior to manufacture of a full size miniature mural.
- B. Submit one full size miniature strike-off for approval prior to the manufacture of full size mural.

- C. Submit manufacturers' product data and installation instructions for each digitally printed wallcovering mural, adhesive and accessory required.
 - 1. Include data on physical properties, fire hazard classification and fire detection characteristics of wallcovering.
 - 2. Include manufacturer's recommendations for maximum permissible moisture content of substrate.
- D. Submit full-size samples, 54 inches wide by 36 inches long, cut from current production of each ground wallcovering selected to demonstrate quality, weight, color and embossing.
- E. Submit manufacturer's written product certification that all furnished wallcovering ground meets or exceeds the specification requirements. Include certified copies of tests specified.
- F. Submit wallcovering ground manufacturer's written instructions for recommended maintenance of each type of wallcovering required.

1.5. QUALITY ASSURANCE

- A. Manufacturer: Provide each type of digitally printed vinyl wallcovering mural required produced by one manufacturer whose published product literature clearly indicates compliance of wallcovering ground with specified requirements.
- B. Applicator: Installation by skilled commercial wallcovering applicators with no less than three years of documented experience installing wallcovering murals of the types and extent specified for the project.
- C. Material Standards: Provide materials that meet or exceed Federal Specification CCC-W-408A and WA-101 Quality Standard for Polymer Coated Fabric Wallcovering for Type I and Type II wallcovering.
- D. Physical Properties: Provide wallcovering with the following physical properties when tested in accordance with ASTM D751.
 - 1. Total weight: 20 oz./lin. yd
 - 2. Tensile Strength: 50x55 Minimum (WxF)
 - 3. Tear Strength: 25x25 Minimum (WxF)
- E. Fire Hazard Classification: Provide materials that comply with Class A fire rating when tested in accordance with ASTM E84.
- F. Underwriters Laboratories approval: Provide materials that have been tested and approved by Underwriters Laboratories.
- G. Fire Detection Characteristics: Provide materials that have been laboratory tested for the Early Warning Effect® in accordance with ASTM E603. Submit test results certifying that when one square foot section of the materials is heated to 300 degrees F, the wallcovering emits an odorless, colorless non-toxic vapor that will activate an ionization smoke detector.

1.6. PRODUCT DELIVERY, STORAGE AND HANDLING

- A. Deliver digitally printed vinyl wallcovering mural to the project site in unbroken and undamaged wrappings and clearly labeled with the manufacturer's identification label, quality or grade, UL label and sidemark.
- B. Store materials in a clean, dry storage area with temperature maintained above 55 degrees with normal humidity.
- C. Store material in a flat position to prevent damage to roll-ends. Do not cross stack material. Support material off the floor in a manner to prevent sagging and warping.

1.7. PROJECT CONDITIONS

- A. Do not apply digitally printed wallcovering mural when surface and ambient temperatures are outside the temperature ranges required by the wallcovering manufacturer.
- B. Provide continuous ventilation and heating facilities to maintain substrate surface and ambient temperatures above 60 degrees F unless required otherwise by manufacturer's instructions.
- C. Apply adhesive only when substrate surface temperature or ambient temperature is above 60 degrees, F, or relative humidity is below 40 percent.
- D. Maintain constant recommended temperature and humidity for at least 72 hours prior to, throughout the installation period and for 72 hours after wallcovering installation completion.
- E. Provide not less than an 80 foot candles per square foot lighting level minimum measured mid height at substrate surfaces.

1.8. WARRANTY

- A. Submit manufacturer's 5 year written warranty against manufacturing defects.

PART 2 - PRODUCTS

2.1. APPROVED MANUFACTURERS

- A. Digitally Printed Wallcovering Mural: Koroseal Digitally Printed Wallcovering Murals manufactured by Koroseal Interior Products, LLC.
- B. Digitally Printed Wallcovering Mural: TRI-KES digitally printed wallcovering murals manufactured by TRI-KES. Contact Sales representative: Joe Brown, 801-200-8120.
- C. Digitally Printed Wallcovering Mural: Subject to compliance with specified requirements, vinyl type, ink, etc., digitally printed murals produced by Capitol Copy and Print, DBA Blueprint Specialties, Boise, Idaho.

2.2 MATERIALS

- A. Wallcoverings: Type II conforming to Federal Specification CCC-W-408A using test methods given in Federal Specification CCC-T-191 b accepted as otherwise specified.
 - 1. Total Weight: 20 ounces per linear yard.
 - 2. Backing Weight: 3.1 ounces per linear yard.
 - 3. Vinyl Weight: 17.9 ounces per linear yard.
 - 4. Thickness: 0.018 to 0.026 inches.
 - 5. Fabric backing and content: Poly-Cotton Woven.
 - 6. Panel Width: 54" wide, max print width 52".
- B. Digital Image: Manufacturer/supplier to include 12 hours of design time and set up fee to furnish and customize digital image obtained utilizing stock image site. Image and associated text and/or artwork shall then be digitally printed with UV inks on digital surface Type II wallcovering. Owner/Architect will be involved in the selection and customizing of the digital image and any customizing artwork or text.
- C. Scope: Wallcovering mural location and nominal width is indicated on Drawings. Mural height shall be floor to ceiling.

2.3. ACCESSORIES

- A. Adhesives: Heavy-Duty Premixed vinyl adhesive.
- B. Substrate Primer/Sealer: White pigmented alkyd or acrylic/latex base primer specifically formulated for use with vinyl wallcoverings.
- C. Metal Moldings: Extruded aluminum, alloy 6063-T5, long lengths, with fine satin mechanical finish and class 2 clear architectural anodic coating conforming to AA M21A31 designed for use with vinyl wallcoverings. Heavy duty plastic subject to Architect approval. See Drawings.
- D. Topcoat Sealer: Equal to "Dreamscape" Dreamguard Protex 3, topcoat to protect wall art from marks, scuffs, scraps and stains.

PART 3 - EXECUTION

3.1. EXAMINATION

- A. Examine substrates and installation conditions.
- B. Test substrates with a suitable moisture meter and verify that moisture content does not exceed 4 percent.
- C. Verify substrate surfaces are clean, dry, smooth, structurally sound and free from surface defects and imperfections that would show through the finished surface. Substrate shall be primed gypsum board with a minimum Level 4 finish.
- D. Evaluate all painted surfaces for the possibility of pigment bleed-through.

- E. Notify the Contractor and Architect in writing of any conditions detrimental to the proper and timely completion of the installation. Beginning of installation means acceptance of surface conditions.

3.2. INSTALLATION

- A. Allow digitally printed vinyl wallcovering mural to acclimatize to the area of installation a minimum of 24 hours before installation.
- B. Before cutting, examine image and color and determine that they are the correct image and color as specified for the correct location.
- C. Read and follow the instructions in the manufacturer's installation sheet contained in each roll of the digitally printed vinyl wallcovering mural.
- D. Use adhesive recommended by the wallcovering manufacturer.
- E. Install each panel in sequence as indicated on the drawings.
- F. If there are variations in color or image that are considered to be excessive, notify the manufacturer's representative for an inspection before any further wallcovering is installed.
- G. Smooth wallcovering to the hanging surface using a stiff bristled sweep brush to eliminate air bubbles, wrinkles, gaps and overlaps.
- H. Remove excess adhesive along finished seams immediately after each wallcovering strip applied. Use clean warm water, a natural sponge and clean towels. Change water often to maintain water cleanliness.

3.3. CLEAN-UP COMPLETION

- A. Upon completion of the work, remove surplus materials, rubbish and debris resulting from the wallcovering installation. Leave areas in neat clean and orderly condition.

END OF SECTION 097200

THIS PAGE INTENTIONALLY BLANK

SECTION 098413 - FIXED SOUND-ABSORPTIVE PANELS

PART 1 - GENERAL

1.1 RELATED DOCUMENTS

- A. Drawings and general provisions of the Contract, including General and Supplementary Conditions and Division 01 Specification Sections, apply to this Section.

1.2 SUMMARY

- A. This Section includes field fabricated acoustical wall panels.
- B. Related Specification Sections
 - 1. Specification Section 099123 – Painting for painting of panels.
- C. Acoustical wall panels as specified herein are field fabricated panels consisting of components as specified and components as shown on details of the Drawings, including the following:
 - 1. “Tectum” Finale Panels.
 - 2. Anchors and attachments.

1.3 SUBMITTALS

- A. Product Data: For each type of product indicated.
- B. Painting Instructions: Provide specifications for painting by others to assure that acoustic performance of panels is not jeopardized.

1.4 QUALITY ASSURANCE

- A. Fabricator Qualifications: Shop that employs skilled workers who custom-fabricate products similar to those required for this Project and whose products have a record of successful in-service performance.
- B. Source Limitations: Obtain acoustical surface panels through one source from a single manufacturer.
- C. Fire-Test-Response Characteristics: Provide acoustical wall panels with the following surface-burning characteristics as determined by testing identical products per ASTM E 84 by UL or another testing and inspecting agency acceptable to authorities having jurisdiction:
 - 1. Flame-Spread Index: 25 or less.
 - 2. Smoke-Developed Index: 450 or less.

1.5 DELIVERY, STORAGE, AND HANDLING

- A. Deliver materials and panels in unopened bundles and store in a temperature-controlled dry place with adequate air circulation.
- B. Protect panel edges from crushing and impact.

1.6 PROJECT CONDITIONS

- A. Environmental Limitations: Do not install acoustical wall panels until spaces are enclosed and weatherproof, wet work in spaces is complete and dry, work above ceilings is complete, and ambient temperature and humidity conditions are maintained at the levels indicated for Project when occupied for its intended use.

1.7 EXTRA MATERIALS

- A. Furnish extra materials described below, before installation begins, that match products installed and that are packaged with protective covering for storage and identified with labels describing contents.
 - 1. Tectum: (2) extra panels in each specified size.

PART 2 - PRODUCTS

2.1 MANUFACTURERS / PRODUCTS

- A. Tectum Wall Panels
 - 1. Tectum products as manufacturer by Tectum, Inc., Newark, Ohio.
 - a. "Finale Wall Panels", 1 inch Tectum with integral 1" fiber core, 2" total thickness. Primed for field painting. Sizes as noted on Drawings.
- B. Beveled Edges
 - 1. Provide beveled edge on all sides of each panel.
- C. Painting of Panels: All panels shall be painted per the manufacturer's recommendations. Colors to be selected by Architect. (2) colors maximum. One color per panel.

PART 3 - EXECUTION

3.1 EXAMINATION

- A. Examine substrates, and conditions for compliance with requirements, installation tolerances, and other conditions affecting performance of acoustical wall panels.

1. Proceed with installation only after unsatisfactory conditions have been corrected.

3.2 FABRICATION AND MOUNTING

- A. Mount acoustic wall panels directly on concrete masonry unit walls per manufacturer requirements but not less than minimum 3/8 inch x 4 inch counter sunk, self-tapping, threaded masonry anchors, (6) per 4x8 panel and (4) per 4x4 panel. Caulk screw heads prior to painting, or if panels are painted prior to installation, touch-up paint caulked screw heads. Refer to Drawings for additional details.
- B. Mount acoustical wall panels in locations indicated with vertical surfaces and edges plumb, top edges level and in alignment with other panels, faces flush, and scribed to fit adjoining work accurately at borders and at penetrations.

3.3 PROTECTION

- A. Provide final protection and maintain conditions, in a manner acceptable to manufacturer and Installer, to ensure that acoustical wall panels are without damage or deterioration at time of Substantial Completion.
- B. Replace acoustical wall panels that cannot be cleaned and repaired, in a manner approved by Architect, before time of Substantial Completion.

END OF SECTION 098413

THIS PAGE INTENTIONALLY BLANK

SECTION 099113 - EXTERIOR PAINTING

PART 1 - GENERAL

1.1 RELATED DOCUMENTS

- A. Drawings, Division 01 Specifications Sections, and provisions of Agreement between Andersen Construction Company, hereinafter referred to as "Contractor", and Subcontractor apply to this Section.

1.2 SUMMARY

- A. Section includes surface preparation and the application of paint systems on the following exterior substrates:
 - 1. Steel.
 - a. Includes steel and hollow metal doors and frames.
 - b. Includes exposed exterior steel lintels.
 - c. Includes miscellaneous railings and existing fence post sleeves.
- B. Related Requirements:
 - 1. Division 09 Section "Interior Painting" for surface preparation and the application of paint systems on interior substrates.

1.3 DEFINITIONS

- A. Gloss Level 1: Not more than 5 units at 60 degrees and 10 units at 85 degrees, according to ASTM D 523.
- B. Gloss Level 3: 10 to 25 units at 60 degrees and 10 to 35 units at 85 degrees, according to ASTM D 523.
- C. Gloss Level 4: 20 to 35 units at 60 degrees and not less than 35 units at 85 degrees, according to ASTM D 523.
- D. Gloss Level 5: 35 to 70 units at 60 degrees, according to ASTM D 523.
- E. Gloss Level 6: 70 to 85 units at 60 degrees, according to ASTM D 523.
- F. Gloss Level 7: More than 85 units at 60 degrees, according to ASTM D 523.

1.4 ACTION SUBMITTALS

- A. Product Data: For each type of product. Include preparation requirements and application instructions. Include MSDS Sheets.
- B. Samples for Initial Selection: For each type of topcoat product.
- C. Samples for Verification: For each topcoat product color and gloss indicated.

1.5 QUALITY ASSURANCE

- A. MPI Standards:
 - 1. Products: Complying with Master Painters Institute (MPI) standards indicated and listed in “MPI Approved Products List.”
 - 2. Preparation and Workmanship: Comply with requirements in “MPI Architectural Painting Specification Manual” for products and paint systems indicated.

1.6 DELIVERY, STORAGE, AND HANDLING

- A. Store materials not in use in tightly covered containers in well-ventilated areas with ambient temperatures continuously maintained at not less than 45 deg F (7 deg C).
 - 1. Maintain containers in clean condition, free of foreign materials and residue.
 - 2. Remove rags and waste from storage areas daily.

1.7 FIELD CONDITIONS

- A. Apply paints only when temperature of surfaces to be painted and ambient air temperatures are between 50 and 95 deg F (10 and 35 deg C).
- B. Do not apply paints in snow, rain, fog, or mist; when relative humidity exceeds 85 percent; at temperatures less than 5 deg F (3 deg C) above the dew point; or to damp or wet surfaces.

1.8 EXTRA MATERIALS

- A. Furnish extra materials described below that are from same production run (batch mix) as materials applied and that are packaged for storage and identified with labels describing contents.
 - 1. Quantity: Furnish and additional 5 percent, but not less than 1 gal. (3.8 L) of each material and color applied.

PART 2 - PRODUCTS

2.1 MANUFACTURERS

- A. Manufacturers: Subject to compliance with requirements, manufacturers offering products that may be incorporated into the Work are set forth below.
 - 1. Benjamin Moore & Co.
 - 2. PPG Architectural Finishes, Inc.
 - 3. Sherwin-Williams Company.
 - 4. Rodda Paint Co.

2.2 PAINT, GENERAL

- A. MPI Standards: Provide products that comply with MPI standards indicated and that are listed in its "MPI Approved Products List."
- B. Material Compatibility:
 - 1. Provide materials for use within each paint system that are compatible with one another and substrates indicated, under conditions of service and application as demonstrated by manufacturer, based on testing and field experience.
 - 2. For each coat in a paint system, provide products recommended in writing by manufacturers of topcoat for use in paint system and on substrate indicated.
- C. VOC Content: Provide materials that comply with VOC limits of authorities having jurisdiction.
- D. Colors: A maximum of three steel colors will be selected by Architect from manufacturer's full range.

2.3 METAL PRIMERS

- A. Primer, Acrylic, rust inhibitive, water based MPI #107
- B. Primer, Galvanized, Water Based: MPI #134.

2.4 LATEX PAINTS

- A. High Performance Architectural Latex, Light industrial coating, exterior Semi-Gloss (Gloss Level 5): MPI #163.

2.5 SOURCE QUALITY CONTROL

- A. Testing of Paint Materials: Owner and Contractor reserve the right to invoke the following procedure:

1. Owner or Contractor may engage the services of a qualified testing agency to sample paint materials. Contractor will be notified in advance and may be present when samples are taken. If paint materials have already been delivered to Project site, samples may be taken at Project site. Samples will be identified, sealed, and certified by testing agency.
2. Testing agency will perform tests for compliance with product requirements.
3. Contractor may direct Subcontractor to stop applying paints if test results show materials being used do not comply with product requirements. Subcontractor shall remove noncomplying paint materials from Project site, pay for testing, and repaint surfaces painted with rejected materials. Subcontractor will be required to remove rejected materials from previously painted surfaces if, on repainting with complying materials, the two paints are incompatible.

PART 3 - EXECUTION

3.1 EXAMINATION

- A. Examine substrates and conditions, with Applicator present, for compliance with requirements for maximum moisture content and other conditions affecting performance of the Work.
- B. Verify suitability of substrates, including surface conditions and compatibility with existing finishes and primers.
- C. Proceed with coating application only after unsatisfactory conditions have been corrected.
 1. Application of coating indicates acceptance of surfaces and conditions.

3.2 PREPARATION

- A. Comply with manufacturer's written instructions and recommendations in "MPI Manual" applicable to substrates and paint systems indicated.
- B. Remove hardware, covers, plates, and similar items already in place that are removable and are not to be painted. If removal is impractical or impossible because of size or weight of item, provide surface-applied protection before surface preparation and painting.
 1. After completing painting operations, use workers skilled in the trades involved to reinstall items that were removed. Remove surface-applied protection.
- C. Clean substrates of substances that could impair bond of paints, including dust, dirt, oil, grease, and incompatible paints and encapsulants.
 1. Remove incompatible primers and reprime substrate with compatible primers or apply tie coat as required to produce paint systems indicated.
- D. Steel Substrates: Remove rust, loose mill scale, and shop primer if any. Clean using methods recommended in writing by paint manufacturer but not less than the following:
 1. SSPC-SP 2, "Hand Tool Cleaning."
 2. SSPC-SP 3, "Power Tool Cleaning."

3. SSPC-SP 7/NACE No. 4, "Brush-off Blast Cleaning."
 4. SSPC-SP 11, "Power Tool Cleaning to Bare Metal."
- E. Shop-Primed Steel Substrates: Clean field welds, bolted connections, and abraded areas of shop paint, and paint exposed areas with the same material as used for shop priming to comply with SSPC-PA 1 for touching up shop-primed surfaces. Clean using methods recommended in writing by paint manufacturer.
- F. Galvanized-Metal Substrates: Remove grease and oil residue from galvanized sheet metal by mechanical methods to produce clean, lightly etched surfaces that promote adhesion of subsequently applied paints.

3.3 APPLICATION

- A. Apply paints according to manufacturer's written instructions and recommendations in "MPI Manual."
1. Use applicators and techniques suited for paint and substrate indicated.
 2. Paint surfaces behind movable items same as similar exposed surfaces. Before final installation, paint surfaces behind permanently fixed items with prime coat only.
 3. Paint both sides and edges of exterior doors and entire exposed surface of exterior door frames.
 4. Do not paint over labels of independent testing agencies or equipment name, identification, performance rating, or nomenclature plates.
 5. Primers specified in painting schedules may be omitted on items that are factory primed or factory finished if acceptable to topcoat manufacturers.
- B. Tint undercoats same color as topcoat, but tint each undercoat a lighter shade to facilitate identification of each coat if multiple coats of same material are to be applied. Provide sufficient difference in shade of undercoats to distinguish each separate coat.
- C. If undercoats or other conditions show through topcoat, apply additional coats until cured film has a uniform paint finish, color, and appearance.
- D. Apply paints to produce surface films without cloudiness, spotting, holidays, laps, brush marks, roller tracking, runs, sags, ropiness, or other surface imperfections. Cut in sharp lines and color breaks.
- E. Do not paint Electrical, Communication, and Electronic Safety and Security work.

3.4 FIELD QUALITY CONTROL

- A. Dry Film Thickness Testing: Owner or Contractor may engage the services of a qualified testing and inspecting agency to inspect and test paint for dry film thickness.
1. Contractor shall touch up and restore painted surfaces damaged by testing.
 2. If test results show that dry film thickness of applied paint does not comply with paint manufacturer's written recommendations, Subcontractor shall pay for testing and apply

additional coats as needed to provide dry film thickness that complies with paint manufacturer's written recommendations.

3.5 CLEANING AND PROTECTION

- A. At end of each workday, remove rubbish, empty cans, rags, and other discarded materials from Project site.
- B. After completing paint application, clean spattered surfaces. Remove spattered paints by washing, scraping, or other methods. Do not scratch or damage adjacent finished surfaces.
- C. Protect work of other trades against damage from paint application. Correct damage to work of other trades by cleaning, repairing, replacing, and refinishing, as approved by Architect, and leave in an undamaged condition.
- D. At completion of construction activities of other trades, touch up and restore damaged or defaced painted surfaces.

3.6 EXTERIOR PAINTING SCHEDULE

- A. Steel Substrates:
 - 1. Water-Based Light Industrial Coating System:
 - a. Prime Coat: Primer, acrylic, rust inhibitive for metal, MPI #107.
 - b. Prime Coat: Shop primer specified in Division 05 Section where substrate is specified.
 - c. Intermediate Coat: Light industrial coating, exterior, water based, matching topcoat.
 - d. Topcoat: Light industrial coating, exterior, water based, semi-gloss (Gloss Level 5), MPI #163.
 - 2. Galvanized Metal Substrates
 - a. Prime Coat: Primer, acrylic, galvanized, water based, MPI #134.
 - b. Prime Coat: Shop primer specified in Division 05 Section where substrate is specified.
 - c. Intermediate Coat: Light industrial coating, exterior, water based, matching topcoat.
 - d. Topcoat: Light industrial coating, exterior, water based, semi-gloss (Gloss Level 5), MPI #163.

END OF SECTION 099113

SECTION 099123 - INTERIOR PAINTING

PART 1 - GENERAL

1.1 RELATED DOCUMENTS

- A. Drawings and general provisions of the Contract, including General and Supplementary Conditions and Division 01 Specification Sections, apply to this Section.

1.2 SUMMARY

- A. This Section includes surface preparation and the application of paint systems on the following interior substrates:
 - 1. Gypsum board and plaster.
 - 2. Concrete and concrete masonry.
 - 3. Steel, including overhead steel.
 - 4. Concrete floor sealing.
 - 5. Tectum sound panels.
 - 6. Wood flooring.

1.3 SUBMITTALS

- A. Product Data: For each type of product indicated.
- B. Samples for Color Selections: For each type of topcoat product indicated.

1.4 QUALITY ASSURANCE

- A. MPI Standards:
 - 1. Products: Complying with Master Painters Institute (MPI) standards indicated and listed in "MPI Approved Products List."
 - 2. Preparation and Workmanship: Comply with requirements in "MPI Architectural Painting Specification Manual" for products and paint systems indicated.

1.5 DELIVERY, STORAGE, AND HANDLING

- A. Store materials not in use in tightly covered containers in well-ventilated areas with ambient temperatures continuously maintained at not less than 45 deg F (7 deg C).
 - 1. Maintain containers in clean condition, free of foreign materials and residue.
 - 2. Remove rags and waste from storage areas daily.

1.6 PROJECT CONDITIONS

- A. Apply paints only when temperature of surfaces to be painted and ambient air temperatures are between 50 and 95 deg F (10 and 35 deg C).
- B. Do not apply paints when relative humidity exceeds 85 percent; at temperatures less than 5 deg F (3 deg C) above the dew point; or to damp or wet surfaces.

1.7 EXTRA MATERIALS

- A. Furnish extra materials described below that are from same production run (batch mix) as materials applied and that are packaged for storage and identified with labels describing contents.
 - 1. Quantity: Furnish an additional 5 percent, but not less than 1 gal. (3.8 L) of each material and color applied.

PART 2 - PRODUCTS

2.1 MANUFACTURERS

- A. Available Manufacturers: Subject to compliance with requirements, manufacturers offering products that may be incorporated into the Work include, but are not limited to, the following:
- B. Manufacturers: Subject to compliance with requirements, provide products by one of the following:
 - 1. Benjamin Moore & Co.
 - 2. PPG Architectural Finishes, Inc.
 - 3. Sherwin-Williams Company.
 - 4. Rodda Paint Company

2.2 PAINT, GENERAL

- A. Material Compatibility:
 - 1. Provide materials for use within each paint system that are compatible with one another and substrates indicated, under conditions of service and application as demonstrated by manufacturer, based on testing and field experience.
 - 2. For each coat in a paint system, provide products recommended in writing by manufacturers of topcoat for use in paint system and on substrate indicated.
- B. Typical Paint Colors: As selected by Architect from manufacturer's full range, including colors requiring deep tone tint base. A maximum of (10) interior colors will be selected. A maximum of (2) of any of the colors selected may be selected for use on walls in any single room or space for which paint is indicated, with the exception of the Gymnasium and Cafeteria, where a maximum of (3) wall colors per room may be selected.

2.3 PRIMERS/SEALERS

- A. Interior Latex Primer/Sealer: MPI #50.
- B. Interior Latex Block Filler: MPI #4.
- C. Interior Latex Wood Primer: MPI #39

2.4 METAL STEEL PRIMER

- A. Quick Dry Primer (Alkyd): MPI #76.
- B. Anti-Corrosive Primer (Alkyd): MPI #79.
- C. Interior Alkyd Primer/Sealer: MPI #45.

2.5 LATEX PAINTS

- A. Latex: MPI #60, MPI #118, MPI #133 and MPI #151.
- B. High-Performance Architectural Latex MPI # 140 and MPI # 141.
- C. High-Performance Architectural Latex (Semigloss): MPI #141 (Gloss Level 5).
- D. Light Industrial Latex, interior (Gloss Level 3): MPI #52

2.6 WOOD SUBSTRATES

- A. Interior Latex, high performance architectural, (Semigloss): MPI #141 (Gloss Level 5).

2.7 CONCRETE SEALER

- A. Interior / Exterior Water Based: MPI #99.

PART 3 - EXECUTION

3.1 EXAMINATION

- A. Examine substrates and conditions, with Applicator present, for compliance with requirements for maximum moisture content and other conditions affecting performance of work.
- B. Maximum Moisture Content of Substrates: When measured with an electronic moisture meter as follows:
 - 1. Concrete and Concrete Masonry: 12 percent.
 - 2. Wood: 15 percent.

3. Gypsum Board and Plaster: 12 percent.
- C. Verify suitability of substrates, including surface conditions and compatibility with existing finishes and primers.
- D. Begin coating application only after unsatisfactory conditions have been corrected and surfaces are dry.
 1. Beginning coating application constitutes Contractor's acceptance of substrates and conditions.

3.2 PREPARATION

- A. Comply with manufacturer's written instructions and recommendations in "MPI Architectural Painting Specification Manual" applicable to substrates indicated.
- B. Remove plates, machined surfaces, and similar items already in place that are not to be painted. If removal is impractical or impossible because of size or weight of item, provide surface-applied protection before surface preparation and painting.
 1. After completing painting operations, use workers skilled in the trades involved to reinstall items that were removed. Remove surface-applied protection if any.
 2. Do not paint over labels of independent testing agencies or equipment name, identification, performance rating, or nomenclature plates.
- C. Clean substrates of substances that could impair bond of paints, including dirt, oil, grease, and incompatible paints and encapsulants.
 1. Remove incompatible primers and reprime substrate with compatible primers as required to produce paint systems indicated.
- D. Concrete and Concrete Masonry Substrates: Remove release agents, curing compounds, efflorescence, and chalk. Do not paint surfaces if moisture content or alkalinity of surfaces to be painted exceeds that permitted in manufacturer's written instructions.
- E. Steel Substrates: Remove rust and loose mill scale. Clean using methods recommended in writing by paint manufacturer.
- F. Galvanized-Metal Substrates: Remove grease and oil residue from galvanized sheet metal fabricated from coil stock by mechanical methods to produce clean, lightly etched surfaces that promote adhesion of subsequently applied paints.
 1. Prime edges, ends, faces, undersides, and backsides of wood.
 2. After priming, fill holes and imperfections in the finish surfaces with putty or plastic wood filler. Sand smooth when dried.
- G. Gypsum Board Substrates: Do not begin paint application until finishing compound is dry and sanded smooth. Pre-prime all surfaces prior to application of spray texture.

3.3 APPLICATION

- A. Apply paints according to manufacturer's written instructions.
 - 1. Use applicators and techniques suited for paint and substrate indicated.
 - 2. Paint surfaces behind movable equipment and furniture same as similar exposed surfaces. Before final installation, paint surfaces behind permanently fixed equipment or furniture with prime coat only.
 - 3. Paint front and backsides of access panels, removable or hinged covers, and similar hinged items to match exposed surfaces.
 - 4. Minimum total prime, intermediate, and topcoat dry film thickness shall be 5.0 mils, and greater as required.
- B. Tint each undercoat a lighter shade to facilitate identification of each coat if multiple coats of same material are to be applied. Tint undercoats to match color of topcoat but provide sufficient difference in shade of undercoats to distinguish each separate coat.
- C. If undercoats or other conditions show through topcoat, apply additional coats until cured film has a uniform paint finish, color, and appearance.
- D. Apply paints to produce surface films without cloudiness, spotting, holidays, laps, brush marks, roller tracking, runs, sags, ropiness, or other surface imperfections. Cut in sharp lines and color breaks.
- E. Painting Mechanical and Electrical Work: Paint items exposed in equipment rooms and occupied spaces including, but not limited to, the following:
 - 1. Mechanical Work:
 - a. Uninsulated metal piping.
 - b. Uninsulated plastic piping.
 - c. Pipe hangers and supports.
 - d. Tanks that do not have factory-applied final finishes.
 - e. Visible portions of internal surfaces of metal ducts, without liner, behind air inlets and outlets.
 - f. Duct, equipment, and pipe insulation having cotton or canvas insulation covering or other paintable jacket material.
 - g. Mechanical equipment that is indicated to have a factory-primed finish for field painting.
 - h. Visible roof top mechanical equipment whether or not factory primed or finish coated.
 - 2. Electrical Work:
 - a. Switchgear.
 - b. Panelboards.
 - c. Electrical equipment that is indicated to have a factory-primed finish for field painting.

3.4 FIELD QUALITY CONTROL

- A. Testing of Paint Materials: Owner reserves the right to invoke the following procedure at any time and as often as Owner deems necessary during the period when paints are being applied:
 - 1. Owner will engage the services of a qualified testing agency to sample paint materials being used. Samples of material delivered to Project site will be taken, identified, sealed, and certified in presence of Contractor.
 - 2. Testing agency will perform tests for compliance with product requirements.
 - 3. Owner may direct Contractor to stop applying paints if test results show materials being used do not comply with product requirements. Contractor shall remove noncomplying-paint materials from Project site, pay for testing, and repaint surfaces painted with rejected materials. Contractor will be required to remove rejected materials from previously painted surfaces if, on repainting with complying materials, the two paints are incompatible.

3.5 CLEANING AND PROTECTION

- A. At end of each workday, remove rubbish, empty cans, rags, and other discarded materials from Project site.
- B. After completing paint application, clean spattered surfaces. Remove spattered paints by washing, scraping, or other methods. Do not scratch or damage adjacent finished surfaces.
- C. Protect work of other trades against damage from paint application. Correct damage to work of other trades by cleaning, repairing, replacing, and refinishing, as approved by Architect, and leave in an undamaged condition.
- D. At completion of construction activities of other trades, touch up and restore damaged or defaced painted surfaces.

3.6 INTERIOR PAINTING SCHEDULE

- A. CMU and Concrete Substrates:
 - 1. High-Performance Architectural Latex System:
 - a. Block Filler: Block filler, latex, interior/exterior, MPI #4.
 - b. Intermediate Coat: Latex, interior, high performance architectural, matching topcoat.
 - c. Topcoat: Latex, interior, high performance architectural, (Gloss Level 4), MPI #140 and/or
 - d. Topcoat: Latex, interior high performance architectural, semi-gloss (Gloss Level 5), MPI # 141 per Architect/Interior Designer.
- B. Steel Substrates, Overhead:
 - 1. Water-Based Dry-Fall System:

- a. Prime Coat: Primer, anti-corrosive, for metal, MPI #79 or primer quick dry, for metal, MPI # 76.
 - b. Topcoat: Dry fall, latex, flat, MPI #118.
 - c. Topcoat: Dry fall, water based, for galvanized steel, flat (Gloss Level 1), MPI #133.

- C. Steel Substrates, General:
 - 1. Water Based Light Industrial Coating System:
 - a. Prime Coat: Primer, anti-corrosive, for metal, MPI #79.
 - b. Intermediate Coat: Light industrial coating, water-based, interior, matching topcoat.
 - c. Topcoat: Light industrial coating, water-based, interior, semi-gloss (Gloss Level 5) MPI #163.

- D. Gypsum Board and Plaster Substrates:
 - 1. High-Performance Architectural Latex System:
 - a. Pre-Prime Coat: Primer sealer, latex, interior, MPI #50.
 - b. Prime Coat: Prime sealer, latex, interior MPI #50.
 - c. Intermediate Coat: Latex, interior, high performance architectural, matching topcoat.
 - d. Topcoat: Latex, interior, high performance architectural, (Gloss Level 4), MPI #140 and/or.
 - e. Topcoat: Latex, interior, high performance architectural, semi-gloss (Gloss Level 5), MPI #141 per Architect/Interior Designer.

- E. Tectum Sound Panels:
 - 1. Water-Based Dry-Fall System:
 - a. Base / Top Coat: Dry-Fall latex, flat, MPI #118. (Spray paint Tectum panels in place, 3.5-5.0 wet mils, 1.5-2.0 dry mils, per Tectum Marketing Bulletin M77.)

- F. Concrete Floor Sealing:
 - 1. Interior/Exterior Water Based:
 - a. First Coat: MPI #99
 - b. Top Coat: MPI #99

- G. Plywood Flooring (Traffic Surface):
 - 1. Latex Floor Paint System:
 - a. Prime Coat: Primer sealer, alkyd, interior, MPI #45
 - b. Intermediate Coat: Floor Paint, latex, low gloss (max gloss level 3), MPI #60.
 - c. Topcoat: Floor paint, latex, low gloss (max gloss level 3), MPI #60.

END OF SECTION 099123

THIS PAGE INTENTIONALLY BLANK

SECTION 101100 - VISUAL DISPLAY SURFACES

PART 1 - GENERAL

1.1 RELATED DOCUMENTS

- A. Drawings and general provisions of the Contract, including General and Supplementary Conditions and Division 01 Specification Sections, apply to this Section.

1.2 SUMMARY

- A. Section Includes:
 - 1. Markerboards.
 - 2. Tackboards.
 - 3. Tackstrips.
- B. Wood blocking and grounds for visual display unit attachment to walls is included in Division 6 Section, "Rough Carpentry".

1.3 DEFINITIONS

- A. Tackboard: Framed or unframed, tackable, visual display board assembly.
- B. Visual Display Board Assembly: Visual display surface that is factory fabricated into composite panel form, either with or without a perimeter frame; includes markerboards and tackboards.

1.4 SUBMITTALS

- A. Product Data: For each type of product indicated. Include construction details, material descriptions, and dimensions of individual components and profiles.
- B. Shop Drawings: For visual display surfaces. Include plans, elevations, sections, details, and attachments to other work.
 - 1. Show locations of panel joints.
 - 2. Include sections of typical trim members.
- C. Samples for Color Selection: For each type of visual display surface indicated, for units with factory-applied color finishes, and as follows:
 - 1. Actual sections of porcelain-enamel face sheet and tackboard assembly.
 - 2. Fabric swatches of vinyl-fabric-faced tack assemblies.

1.5 QUALITY ASSURANCE

- A. Source Limitations: Obtain visual display surfaces from single source from single manufacturer.
- B. Surface-Burning Characteristics: As determined by testing identical products according to ASTM E 84 by a qualified testing agency. Identify products with appropriate markings of applicable testing agency.
 - 1. Flame-Spread Index: 25 or less.
 - 2. Smoke-Developed Index: 50 or less.

1.6 DELIVERY, STORAGE, AND HANDLING

- A. Deliver factory-built visual display surfaces, including factory-applied trim where indicated, completely assembled in one piece without joints, where possible. If dimensions exceed maximum manufactured panel size, provide two or more pieces of equal length as acceptable to Architect. When overall dimensions require delivery in separate units, pre-fit components at the factory, disassemble for delivery, and make final joints at the site.
- B. Store visual display surfaces vertically with packing materials between each unit.

1.7 PROJECT CONDITIONS

- A. Environmental Limitations: Do not deliver or install visual display surfaces until spaces are enclosed and weathertight, wet work in spaces is complete and dry, work above ceilings is complete, and temporary HVAC system is operating and maintaining ambient temperature and humidity conditions at occupancy levels during the remainder of the construction period.

1.8 WARRANTY

- A. Special Warranty for Porcelain-Enamel Face Sheets: Manufacturer's standard form in which manufacturer agrees to repair or replace porcelain-enamel face sheets that fail in materials or workmanship within specified warranty period.
 - 1. Failures include, but are not limited to, the following:
 - a. Surfaces lose original writing and erasing qualities.
 - b. Surfaces exhibit crazing, cracking, or flaking.
 - 2. Warranty Period: Life of the building.

PART 2 - PRODUCTS

2.1 MATERIALS, GENERAL

- A. Porcelain-Enamel Face Sheet: Porcelain-enamel-clad, ASTM A 463/A 463M, Type 1, stretcher-leveled aluminized steel, with 0.024-inch (0.60-mm) uncoated thickness; with porcelain-enamel coating fused to steel at approximately 1000 deg F (538 deg C).
 - 1. Gloss Finish (markerboards): Low gloss; dry-erase markers wipe clean with dry cloth or standard eraser. Suitable for use as projection screen.
- B. Vinyl Fabric: Mildew resistant, washable, complying with FS CCC-W-408D, Type II, burlap weave; weighing not less than 13 oz./sq. yd. with surface-burning characteristics indicated.
- C. Hardboard: ANSI A135.4, tempered.
- D. Particleboard: ANSI A208.1, Grade M-1, made with binder containing no urea formaldehyde.
- E. Fiberboard: ASTM C 208.
- F. Extruded Aluminum: ASTM B 221 (ASTM B 221M), Alloy 6063.

2.2 MARKERBOARD ASSEMBLIES

- A. Porcelain-Enamel Markerboards: Balanced, high-pressure, factory-laminated markerboard assembly of three-ply construction consisting of backing sheet, core material, and porcelain-enamel face sheet with high-gloss finish.
 - 1. Manufacturers: Subject to compliance with requirements, provide products by one of the following:
 - a. ADP Lemco, Inc.
 - b. Platinum Visual Systems.
 - c. Claridge.
 - 2. Products by other manufacturers are subject to approval by Architect prior to bidding.
 - 3. Hardboard Core: 1/4 inch (6 mm) thick; 0.015-inch- (0.38-mm-) thick, aluminum sheet backing.
 - 4. Laminating Adhesive: Manufacturer's standard, moisture-resistant thermoplastic type.
 - 5. Surface: Claridge LCS-II or equivalent.

2.3 TACKBOARD ASSEMBLIES

- A. Manufacturers: Subject to compliance with requirements, provide products by one of the following:
 - 1. ADP Lemco, Inc.
 - 2. Platinum Visual Systems.
 - 3. Claridge

- B. Products by other manufacturers are subject to approval by Architect prior to bidding.
- C. Vinyl-Fabric-Faced Tackboard: 1/4-inch- (6-mm-) thick, vinyl-fabric-faced cork sheet factory laminated to 1/4-inch- (6-mm-) thick hardboard backing.

2.4 TACK STRIPS (DISPLAY RAILS)

- A. Tack Strips: 1 inch height, 3/8 inch thick anodized aluminum with natural cork insert. Length as shown on the drawings.
 - 1. Equivalent to Claridge Model 51EZ, 1 inch high aluminum rail with 5/8 inch cork insert, lengths per Drawings. Install in double tier fashion at 4'-6" and 6'-0" above floor level.

2.5 MARKERBOARD AND TACKBOARD ACCESSORIES

- A. Aluminum Frames and Trim: Fabricated from not less than 0.062-inch- (1.57-mm-) thick, extruded aluminum; standard size and shape.
 - 1. Factory-Applied Trim: Manufacturer's standard.
- B. Marker Tray: Manufacturer's standard, continuous.
 - 1. Solid Type: Extruded aluminum with ribbed section and smoothly curved exposed ends.
 - 2. Do not provide marker trays at the markerboard in the following locations: Gymnasium A110, Classrooms A116 and A119.
- C. Map Rail: Provide the following accessories:
 - 1. Display Rail: Continuous and integral with map rail; fabricated from cork approximately 1 to 2 inches (25 to 50 mm) wide. Do not include an integral display rail at marker boards adjacent to short throw projector locations.
 - 2. End Stops: Located at each end of map rail.
 - 3. Combination Map / Paper Holder: Metal combination map hook / paper holder device, (6) total at larger marker board at each classroom.
 - 4. Flag Holder: One for each room. No more than 60 degree angle from wall plane.

2.6 FABRICATION

- A. Porcelain-Enamel Visual Display Assemblies: Laminate porcelain-enamel face sheet and backing sheet to core material under heat and pressure with manufacturer's standard flexible, waterproof adhesive.
- B. Visual Display Boards: Factory assemble visual display boards unless otherwise indicated.
 - 1. Where factory-applied trim is indicated, trim shall be assembled and attached to visual display boards at manufacturer's factory before shipment.

- C. Factory-Assembled Visual Display Units: Coordinate factory-assembled units with trim and accessories indicated. Join parts with a neat, precision fit.
 - 1. Make joints only where total length exceeds maximum manufactured length. Fabricate with minimum number of joints, balanced around center of board, as acceptable to Architect.
 - 2. Provide manufacturer's standard vertical-joint trim system between abutting sections of markerboards.
 - 3. Where size of visual display boards or other conditions require support in addition to normal trim, provide structural supports or modify trim as indicated or as selected by Architect from manufacturer's standard structural support accessories to suit conditions indicated.

- D. Aluminum Frames and Trim: Fabricate units straight and of single lengths, keeping joints to a minimum. Miter corners to a neat, hairline closure.
 - 1. Where factory-applied trim is indicated, trim shall be assembled and attached to visual display units at manufacturer's factory before shipment.

2.7 GENERAL FINISH REQUIREMENTS

- A. Comply with National Association of Architectural Metal Manufacturers (NAAMM) "Metal Finishes Manual for Architectural and Metal Products" for recommendations for applying and designating finishes.
- B. Protect mechanical finishes on exposed surfaces from damage by applying a strippable, temporary protective covering before shipping.
- C. Appearance of Finished Work: Noticeable variations in same piece are not acceptable. Variations in appearance of adjoining components are acceptable if they are within the range of approved Samples and are assembled or installed to minimize contrast.

2.8 ALUMINUM FINISHES

- A. Clear Anodic Finish: American Architectural Manufacturers Association (AAMA) AAMA 611, AA-M12C22A31, Class II, 0.010 mm or thicker.

2.9 COLORS AND SIZES:

- A. Visual Display Board colors and sizes:
 - 1. Markerboards: White, sizes as indicated on Drawings.
 - 2. Tackboards: A maximum of 4 colors as selected from manufacturer's full range, sizes as indicated on Drawings.

PART 3 - EXECUTION

3.1 EXAMINATION

- A. Examine substrates and conditions, with Installer present, for compliance with requirements for installation tolerances, surface conditions of wall, and other conditions affecting performance of the Work.
- B. Examine walls and partitions for proper preparation and backing for visual display surfaces.
- C. Proceed with installation only after unsatisfactory conditions have been corrected.

3.2 PREPARATION

- A. Comply with manufacturer's written instructions for surface preparation.
- B. Clean substrates of substances that could impair the performance of and affect the smooth, finished surfaces of visual display boards, including dirt, mold, and mildew.

3.3 INSTALLATION, GENERAL

- A. General: Install visual display surfaces in locations and at mounting heights indicated on Drawings, or if not indicated, at heights indicated below. Keep perimeter lines straight, level, and plumb. Provide grounds, clips, backing materials, adhesives, brackets, anchors, trim, and accessories necessary for complete installation.
 - 1. Mounting Heights: As indicated on Drawings.

3.4 INSTALLATION OF FACTORY-FABRICATED VISUAL DISPLAY BOARDS AND ASSEMBLIES

- A. Visual Display Boards: Attach concealed clips, hangers, and grounds to wall surfaces and to visual display boards with fasteners at not more than 16 inches (400 mm) o.c. Secure both top and bottom of boards to walls.
 - 1. Field-Applied Aluminum Trim: Attach trim over edges of visual display boards and conceal grounds and clips. Attach trim to boards with fasteners at not more than 24 inches (610 mm) o.c.
 - a. Attach marker trays to boards with fasteners at not more than 12 inches (300 mm) o.c.
 - b. In grade-level classrooms, install marker board accessories on boards at front of room as follows:
 - 1. Map hooks and flag holder on board on left.
 - 2. Paper holder on board on right.

3.5 CLEANING AND PROTECTION

- A. Clean visual display surfaces according to manufacturer's written instructions. Attach one cleaning label to visual display surface in each room.
- B. Touch up factory-applied finishes to restore damaged or soiled areas.
- C. Cover and protect visual display surfaces after installation and cleaning.

END OF SECTION 101100

THIS PAGE INTENTIONALLY BLANK

SECTION 101416 – SIGNAGE

PART 1 - GENERAL

1.1 RELATED DOCUMENTS

- A. Drawings and general provisions of the Contract, including Division 01 Specification Sections, apply to this Section.

1.2 SUMMARY

- A. This Section includes the following:
 - 1. Panel signs.
- B. ADA-ABA Accessibility Guidelines: U.S. Architectural & Transportation Barriers Compliance Board's "Americans with Disabilities Act (ADA) Accessibility Guidelines for Buildings and Facilities; Architectural Barriers Act (ABA) Accessibility Guidelines."

1.3 SUBMITTALS

- A. Product Data: For each type of product indicated.
- B. Shop Drawings: Show fabrication and installation details for plaques and dimensional letters.
 - 1. Show text/design, mounting heights, locations of supplementary supports to be provided by others, and accessories.
- C. Samples for Color Selection: Manufacturer's color charts consisting of actual units or sections of units showing the full range of colors available for the following:
 - 1. Decorative Panel Signs.

1.4 QUALITY ASSURANCE

- A. Source Limitations for Signs: Obtain each sign type indicated from one source from a single manufacturer.
- B. Regulatory Requirements: Comply with applicable provisions in ADA-ABA Accessibility Guidelines.

PART 2 - PRODUCTS

2.1 PANEL SIGNS

- A. Manufacturers: Subject to compliance with requirements, provide products by one of the following:
1. Best Sign Systems, Inc. – Lucent Series (Basis of Design).
 2. APCO Graphics, Inc.
 3. Supersine Company (The)
- B. Products by other manufacturers are subject to approval by Architect prior to bidding and shall be equal to Best Sign Systems, Inc. – Lucent Series.
- C. Interior Panel Signs: Provide smooth sign panel surfaces constructed to remain flat under installed conditions within a tolerance of plus or minus 1/16 inch (1.5 mm) measured diagonally from corner to corner, complying with the following requirements:
1. Clear Acrylic with colored back and text, 1/8 inch thick.
 2. Edge Condition: Square cut.
 3. Corner Condition: Square.
 4. Mounting: Unframed, at interior walls.
 - a. Wall mounted with two-face tape.
 5. Color: As selected by Architect from manufacturer's full range.
 6. Tactile Characters: Characters and Grade 2 Braille raised 1/32 inch (0.8 mm) above surface with contrasting colors.
- D. Panel Sign Schedule:
1. Sign Type: Laminate Panel Signs.
 - a. Panels: Acrylic, color as selected from manufacturer's standards. 3" high strips, minimum, with square corners.
 - b. Letters/Numbers: Raised letters/numbers complying with Americans with Disability Act (ADA), 1" high, white letters / numbers.
 - c. Braille: Grade 2 braille located on same background panel as, and located below letters/numbers, with same text as letters/numbers, ADA compliant.
 - d. Special Signs: At all toilet rooms, provide 6" x 6" standard accessibility symbol plaque in conjunction with "Men", "Women", "Boys", "Girls", and "Toilet Room" text and corresponding pictographs. Furnish and install "Maximum Occupant Load _____" sign at Cafeteria and Gymnasium. Furnish and install tactile "Exit" sign at all exit discharge doors identified as "Exit" on Drawing Sheet A-1.1."
 - e. Quantity: (100) standard size signs, (10) oversize signs, plus special signs noted above.
 - f. Average letters / characters per sign: (12) on standard signs, (30) on oversize signs.

Note: "Average letters per sign" shall be limited only by: Total letters of all signs of given type (standard or oversize) ÷ total number of signs of that type is less than or equal to quantity specified.

2.2 ACCESSORIES

- A. Anchors and Inserts: Provide nonferrous-metal or hot-dip galvanized anchors and inserts for any exterior panel sign installations, and elsewhere as required for corrosion resistance. Use toothed steel or lead expansion-bolt devices for drilled-in-place anchors. Furnish inserts, as required, to be set into concrete or masonry work.

PART 3 - EXECUTION

3.1 EXAMINATION

- A. Examine substrates, areas, and conditions, with Installer present, for compliance with requirements for installation tolerances and other conditions affecting performance of work.
- B. Verify that items, including anchor inserts, are sized and located to accommodate signs.
- C. Proceed with installation only after unsatisfactory conditions have been corrected.

3.2 INSTALLATION

- A. Locate signs and accessories where indicated, using mounting methods of types described and complying with manufacturer's written instructions.
 - 1. Install signs level, plumb, and at heights indicated, with sign surfaces free of distortion and other defects in appearance.
 - 2. Interior Wall Signs: Install per A.D.A. requirements and detail on Drawings. Install signs on walls adjacent to latch side of door where applicable. Where not indicated or possible, such as double doors, install signs on nearest adjacent walls. Locate to allow approach within 3 inches (75 mm) of sign without encountering protruding objects or standing within swing of door. Height shall be 5'-0" to top of panel.
- B. Wall-Mounted Panel Signs: Comply with sign manufacturer's written instructions except where more stringent requirements apply.
 - 1. Two-Face Tape: Mount signs to smooth, nonporous surfaces. Do not use this method for vinyl-covered or rough surfaces.
 - 2. Silicone-Adhesive Mounting: Attach signs to irregular, porous, or vinyl-covered surfaces.
 - 3. Signs Mounted on Glass: Provide matching opaque plate on opposite side of glass to conceal mounting materials.

3.3 CLEANING AND PROTECTION

- A. After installation, clean soiled sign surfaces according to manufacturer's written instructions. Protect signs from damage until acceptance by Owner.

END OF SECTION 101416

SECTION 102113 - TOILET COMPARTMENTS

PART 1 - GENERAL

1.1 RELATED DOCUMENTS

- A. Drawings and general provisions of the Contract, including General and Supplementary Conditions and Division 01 Specification Sections, apply to this Section.

1.2 SUMMARY

- A. Section Includes:
 - 1. Phenolic-core toilet compartments configured as toilet enclosures and urinal screens.

1.3 SUBMITTALS

- A. Product Data: For each type of product indicated. Include construction details, material descriptions, dimensions of individual components and profiles, and finishes.
- B. Shop Drawings: For toilet compartments. Include plans, elevations, sections, details, and attachments to other work.
 - 1. Show locations of centerlines of toilet fixtures.
- C. Samples for Color Selection: For each type of unit indicated. Include samples of hardware and accessories involving material and color selection.

1.4 QUALITY ASSURANCE

- A. Surface-Burning Characteristics: As determined by testing identical products according to ASTM E 84, or another standard acceptable to authorities having jurisdiction, by a qualified testing agency. Identify products with appropriate markings of applicable testing agency.
 - 1. Flame-Spread Index: 45.
 - 2. Smoke-Developed Index: 110.
- B. Regulatory Requirements: Comply with applicable provisions in ICC/ANSI A117.1 for toilet compartments designated as accessible.

1.5 PROJECT CONDITIONS

- A. Field Measurements: Verify actual locations of toilet fixtures, walls, columns, ceilings, and other construction contiguous with toilet compartments by field measurements before fabrication.

PART 2 - PRODUCTS

2.1 MATERIALS

- A. Stainless-Steel Sheet: ASTM A 666, Type 304, stretcher-leveled standard of flatness.
- B. Stainless-Steel Castings: ASTM A 743/A 743M.

2.2 PHENOLIC-CORE UNITS

- A. Manufacturers: Subject to compliance with requirements, provide products by one of the following:
 - 1. Accurate Partitions Corporation.
 - 2. American Sanitary Partition Corporation.
 - 3. Ampco, Inc.
 - 4. Bobrick Washroom Equipment, Inc.
 - 5. Flush Metal Partition Corp.
 - 6. General Partitions Mfg. Corp.
 - 7. Global Steel Products Corp.
 - 8. Knickerbocker Partition Corporation.
 - 9. Metpar Corp.
- B. Products by other manufacturers are subject to approval by Architect prior to bidding.
- C. Toilet-Enclosure Style:
 - a. Overhead braced, floor anchored, with standard 12" floor clearance.
 - b. Overhead braced, floor anchored, with 1" floor clearance for additional privacy. This partition will occur at one privacy stall location of all public restrooms. Refer to plans for location.
- D. Urinal-Screen Style: Wall hung.
- E. Door, Panel, Screen, and Pilaster Construction: Solid phenolic-core panel material with melamine facing on both sides fused to substrate during panel manufacture (not separately laminated), and with eased and polished edges. Provide minimum 3/4-inch- (19-mm-) thick doors and pilasters and minimum 3/4-inch- (13-mm-) thick panels. 1" floor clearance shall be provided at privacy stall doors.
- F. Pilaster Shoes and Sleeves (Caps): Fabricated from stainless-steel sheet, not less than 0.031-inch (0.79-mm) nominal thickness and 3 inches (76 mm) high, finished to match hardware.
- G. Brackets (Fittings):
 - 1. Full-Height (Continuous) Type: Manufacturer's standard design; stainless steel.
- H. Phenolic-Panel Finish:

1. Facing Sheet Finish: One color and pattern in each room.
2. Colors and Patterns: As selected by Architect from manufacturer's full range, with manufacturer's standard through-color core matching face sheet.
3. A maximum of 2 colors will be selected.

2.3 ACCESSORIES

- A. Hardware and Accessories: Manufacturer's standard design, heavy-duty operating hardware and accessories.
1. Material: Stainless steel.
 2. Hinges: Manufacturer's full-length piano type that swings to a closed or partially open position.
 3. Latch and Keeper: Manufacturer's standard surface-mounted latch unit designed for emergency access and with combination rubber-faced door strike and keeper. Provide units that comply with regulatory requirements for accessibility at compartments designated as accessible.
 4. Coat Hook: Manufacturer's standard combination hook and rubber-tipped bumper, sized to prevent in-swinging door from hitting compartment-mounted accessories.
 5. Door Bumper: Manufacturer's standard rubber-tipped bumper at out-swinging doors.
 6. Door Pull: Manufacturer's standard unit at out-swinging doors that complies with regulatory requirements for accessibility. Provide units on both sides of doors at compartments designated as accessible.
 7. Reduced sightlines at all partition connections and door locations.
- B. Overhead Bracing: Manufacturer's standard continuous, extruded-aluminum head rail with anti-grip profile and in manufacturer's standard finish.
- C. Anchorages and Fasteners: Manufacturer's standard exposed fasteners of stainless steel finished to match the items they are securing, with theft-resistant-type heads. Provide sex-type bolts for through-bolt applications. For concealed anchors, use stainless steel.

2.4 FABRICATION

- A. Overhead-Braced Units: Provide manufacturer's standard corrosion-resistant supports, leveling mechanism, and anchors at pilasters to suit floor conditions. Provide shoes at pilasters to conceal supports and leveling mechanism.
- B. Floor-Anchored Units: Provide manufacturer's standard corrosion-resistant anchoring assemblies with leveling adjustment nuts at pilasters for structural connection to floor. Provide shoes at pilasters to conceal anchorage.
- C. Door Size and Swings: Unless otherwise indicated, provide 24-inch- (610-mm-) wide, in-swinging doors for standard toilet compartments and 36-inch- (914-mm-) wide, out-swinging doors with a minimum 32-inch- (813-mm-) wide, clear opening for compartments designated as accessible.

PART 3 - EXECUTION

3.1 INSTALLATION

- A. General: Comply with manufacturer's written installation instructions. Install units rigid, straight, level, and plumb. Secure units in position with manufacturer's recommended anchoring devices.
 - 1. Maximum Clearances:
 - a. Pilasters and Panels: 1/2 inch (13 mm).
 - b. Panels and Walls: 1 inch (25 mm).
- B. Overhead-Braced Units: Secure pilasters to floor and level, plumb, and tighten. Set pilasters with anchors penetrating not less than 1-3/4 inches (44 mm) into structural floor unless otherwise indicated in manufacturer's written instructions. Secure continuous head rail to each pilaster with no fewer than two fasteners. Hang doors to align tops of doors with tops of panels, and adjust so tops of doors are parallel with overhead brace when doors are in closed position.
- C. Floor-Anchored Units: Set pilasters with anchors penetrating not less than 2 inches (51 mm) into structural floor unless otherwise indicated in manufacturer's written instructions. Level, plumb, and tighten pilasters. Hang doors and adjust so tops of doors are level with tops of pilasters when doors are in closed position.
- D. Urinal Screens: Attach with anchoring devices to suit supporting structure. Set units level and plumb, rigid, and secured to resist lateral impact.

3.2 ADJUSTING

- A. Hardware Adjustment: Adjust and lubricate hardware according to hardware manufacturer's written instructions for proper operation. Set hinges on in-swinging doors to hold doors open approximately 30 degrees from closed position when unlatched. Set hinges on out-swinging doors to return doors to fully closed position.

END OF SECTION 102113

SECTION 102600 - WALL AND DOOR PROTECTION

PART 1 – GENERAL

1.1. RELATED DOCUMENTS

- A. Drawings and general provisions of the Contract, including Division 1 Specification Sections, apply to this Section.

1.2. SUMMARY

- A. This Section includes the following types of wall surface protection systems:

Wall protection systems, including:

- 1. Wall corner guards.
- B. Wood blocking and grounds for surface-mounted corner guards are included in Division 6 Section "Rough Carpentry".

1.3. SUBMITTALS

- A. General: Submit the following in accordance with Conditions of the Contract and Division 1 Specification Sections.
- B. Product data for each wall surface protection system component and installation accessory required, including installation methods for each type of substrate. Provide written data on each required component including physical characteristics, such as durability, resistance to fading, and flame resistance.
- C. Shop drawings showing locations, extent, and installation details of wall and corner guards and other protection systems. Show methods of attachment to adjoining construction.
- D. Samples for Initial Selection: For initial selection of color, pattern and surface texture, provide the manufacturer's standard color chips consisting of actual sections of each vinyl / plastic material required showing the full range of materials, colors, and textures available.
- E. Samples for Verification Purposes: Submit the following samples, prepared from the same material to be used in the Work.
 - 1. 12-inch long samples of each type of wall corner guard product required. Include examples of joinery, corners, and field splices.

1.4. QUALITY ASSURANCE

- A. Installer Qualifications: Engage an experienced installer who has previously installed wall surface protection systems similar in material, design, and extent to the systems indicated for this Project.
- B. Fire Performance Characteristics: Provide wall surface protection system components that are identical to those tested in accordance with ASTM E 84 for the fire performance characteristics indicated below. Identify wall surface protection system components with appropriate markings from the testing and inspection organization.
 - a. Flame Spread: 25 or less.
 - b. Smoke Developed: 450 or less.
- C. Single Source Responsibility: Obtain each color, grade, finish, and type of wall surface protection system component from a single source with resources to provided products of consistent quality in appearance and physical properties without delaying progress of the Work.

1.5. DELIVERY, STORAGE, AND HANDLING

- A. Deliver: Materials to Project site in original factory wrappings and containers, clearly labeled with identification of manufacturer, brand name, quality or grade, and fire hazard classification.
- B. Store: Wall surface protection materials in original undamaged packages and containers inside a well-ventilated area protected from weather, moisture, soiling, extreme temperatures, and humidity.
 - 1. Maintain room temperature within the storage area at not less than 70 deg. F (21 deg. C) during the period plastic materials are stored. Keep sheet material out of direct sunlight to avoid surface distortion.
 - 2. Store rigid plastic corner guard covers in a vertical position, and rigid plastic wall guard covers in a horizontal position for a minimum of 72 hours, or until the plastic material attains the minimum room temperature of 70 deg. F (21 deg C).

1.6. PROJECT CONDITIONS

- A. Environmental Conditions: Do not install wall surface protection system components until the space is enclosed and weatherproof and until the ambient temperature within the building is maintained at not less than 70 deg. F (21 deg. C) for not less than 72 hours prior to beginning of the installation. Do not install rigid plastic wall surface protection systems until that temperature has been attained and is stabilized.

1.7. MAINTENANCE

- A. Maintenance Instructions: Provide the manufacturer's instructions for maintenance of installed work. Include recommended methods and frequency for maintaining optimum condition under anticipated traffic and use conditions. Include precautions against cleaning materials and methods that may be detrimental to finishes and performance.

- B. Replacement Materials: After completion of work, deliver (2) additional corner guard units of each style specified to serve as Owner spare. Include all necessary attachment components as required.

PART 2 - PRODUCTS

2.1. MANUFACTURERS

- A. Manufacturers: Subject to compliance with requirements, provide products by the following:
 - a. Acrovyn by Construction Specialties, Inc.

2.2. MATERIALS

- A. Rigid Plastic Material: Extruded, textured, chemical and stain resistant, high impact, acrylic modified vinyl plastic, thickness as indicated. Comply with specified requirements of ASTM D 256 for impact resistance and ASTM E 84 for flame spread and smoke developed characteristics.
- B. Colors and Textures of Plastic Material: Provide extruded Acrovyn with pebble texture. Single color to be selected by Architect from manufacturer's standards.
- C. Aluminum Extrusions: Provide alloy and temper recommended by the manufacturer for the type of use and finish indicated, but with not less than the strength and durability properties specified in ASTM B 221 for 6063-T5.
- D. Fasteners: Provide aluminum nonmagnetic stainless steel, or other noncorrosive metal screws, bolts, and other fasteners compatible with aluminum components, hardware, anchors, and other items being fastened.

2.3. CORNER GUARDS

- A. Surface Mounted Plastic Corner Guards: Provide manufacturer's standard, embossed, resilient plastic polyvinyl chloride (PVC) or acrylic modified vinyl sheet corner guards, height as indicated on Drawings. Provide 90-degree turns, and formed edges.
 - 1. Model: Acrovyn Models SSM-20AN with 2" wings and 48" height. Shorter lengths at partial height walls. Longer lengths where noted on Drawings.

PART 3 EXECUTION

3.1. EXAMINATION

- A. Examine: Areas and Conditions in which wall surface protection components and wall protection systems will be installed.

- a. Complete all finishing operations, including painting, before beginning installation of wall surface protection system materials.

3.2. PREPARATION

- A. General: Prior to installation, clean substrate to remove dust, debris, and loose particles.

3.3. INSTALLATION

- A. General: Install wall surface protection units plumb, level, and true to line without distortions.
 - a. Do not use materials with chips, cracks, voids, stains, or other defects that might be visible in the finished work.
- B. Install: Aluminum retainers, mounting brackets, and other accessories in strict accordance with the manufacturer's instructions. Install with bottom at top of floor base.

3.4. CLEANING

- A. General: Immediately upon completion of installation, clean plastic covers and accessories using a standard ammonia based household cleaning agent. Clean metal components in accordance with the manufacturer's recommendations.
- B. Remove: Excess adhesive using methods and materials recommended by manufacturer.
- C. Remove surplus materials, rubbish, and debris resulting from installation upon completion of work and leave areas of installation in neat, clean condition.

END OF SECTION 102600

SECTION 102800 - TOILET AND BATH ACCESSORIES

PART 1 - GENERAL

1.1. RELATED DOCUMENTS

- A. Drawings and general provisions of Contract, including Division-1 Specification Sections, apply to this Section.

1.2. SUMMARY

- A. This Section includes the following Contractor furnished and installed stainless steel toilet accessory items:
 - 1. Grab Bars.
 - 2. Framed Mirrors.
 - 3. Stainless Steel Shelf / Mop Holder.
 - 4. Coat Hooks.

1.3. SUBMITTALS

- A. General: Submit the following in accordance with Conditions of Contract and Division 1 Specification Sections.
- B. Product data for each toilet accessory item specified, including details of construction relative to materials, dimensions, gages, profiles, method of mounting, specified options, and finishes.

1.4. QUALITY ASSURANCE

- A. Single-Source Responsibility: Provide products of same manufacturer for each type of accessory unit and for units exposed to view in same areas.

1.5. PROJECT CONDITIONS

- A. Coordination: Coordinate accessory locations, installation, and sequencing with other work to avoid interference and to assure proper installation, operation, adjustment, cleaning, and servicing of toilet accessory items.
- B. Provide backing and blocking in walls and required for mounting of all toilet and bath accessories.

PART 2 - PRODUCTS

2.1. ACCEPTABLE MANUFACTURERS

- A. Available Manufacturers: Subject to compliance with requirements, provide products by one of

the following manufacturers.

1. Bobrick Washroom Equipment, Inc.
2. Bradley Corporation

2.2. MATERIALS

- A. Stainless Steel: AISI Type 302/304, with polished No. 4 finish, 22-gage (.034-inch) minimum thickness, unless otherwise indicated.
- B. Galvanized Steel Mounting Devices: ASTM A 153, hot-dip galvanized after fabrication.
- C. Fasteners: Screws, bolts, and other devices of same material as accessory unit or of galvanized steel where concealed.

2.3. GRAB BARS

- A. Stainless Steel Type: Provide grab bars with wall thickness not less than 18 gauge (.050 inch) and as follows:
 1. Mounting: Concealed, manufacturer's standard flanges and anchorages.
 2. Mounting Height: As per Drawings.
 3. Clearance: 1-1/2 inches clearance between wall surface and inside face of bar.
 4. Gripping Surfaces: Smooth, satin finish.
 5. Heavy-Duty Size: Outside diameter of 1-1/2 inches.
 6. Lengths: See Drawings.

2.4 MIRROR UNITS

- A. Standard Stainless Steel Framed Mirror Units: Fabricate frame with channel shapes of not less than 20 gage (.040 inch.), with square corners carefully mitered to hairline joints and mechanically interlocked. Provide in Type 430 bright polished finish.
- B. Framed Mirror Unit Fabrication: Fabricate frames for glass mirror units to accommodate wood, felt, plastic, or other glass edge protection material. Provide mirror backing and support system that will permit rigid, tamperproof glass installation and prevent accumulation of moisture, as follows:
 1. Provide galvanized steel backing sheet, not less than 22 gage (.034 inch) and full mirror size, with nonabsorptive filler material. Corrugated cardboard is not an acceptable filler material.
- C. Mirror Unit Hangers: Provide system of mounting mirror units that will permit rigid, tamperproof, and theft proof installation , as follows:
 1. One –piece galvanized steel wall hanger device with spring action locking mechanism to hold mirror unit in position with no exposed screws or bolts.

D. Size and Quantities:

1. 18"x36"
2. Provide (1) above each sink in both the male and female restrooms.

2.5 STAINLESS STEEL SHELF/MOP HOLDER

- A. Stainless steel wall mounted shelf.
- B. Manufacturer/Model
 1. Bobrick B-239 x 34 or approved equal.
 2. Provide (1) at each Custodial Room.

2.6 HOOKS

- A. Coat / Towel Hooks
 1. Type 304, 22 gauge stainless steel, equal to Bobrick B-6827.

PART 3 – EXECUTION

3.1 INSTALLATION

- A. Install all toilet and bath accessories according to manufacturer's instructions and requirements.
 1. Attach grab bars and paper product dispensers to in-wall solid wood blocking by others.
- B. Secure mirrors to walls in concealed, tamperproof manner with special hangers, toggle bolts, or screws. Set units plumb, level, and square at locations indicated, in accordance with manufacturer's instructions for type of substrate involved.

END OF SECTION 102800

THIS PAGE INTENTIONALLY BLANK

SECTION 104413 - FIRE EXTINGUISHER CABINETS

PART 1 - GENERAL

1.1 RELATED DOCUMENTS

- A. Drawings and general provisions of the Contract, including General and Supplementary Conditions and Division 01 Specification Sections, apply to this Section.

1.2 SUMMARY

- A. Section Includes:

- 1. Fire protection cabinets for portable fire extinguishers.
 - a. Semi-recessed fire extinguisher cabinets as indicated on the Drawings.

1.3 SUBMITTALS

- A. Product Data: For each type of product indicated. Include construction details, material descriptions, dimensions of individual components and profiles, and finishes for fire protection cabinets.
 - 1. Fire Protection Cabinets: Include roughing-in dimensions, details showing mounting methods, relationships of box and trim to surrounding construction, door hardware, cabinet type, trim style, and panel style.
 - 2. Show location of knockouts for hose valves.

1.4 COORDINATION

- A. Coordinate size of fire protection cabinets to ensure that type and capacity of fire extinguishers indicated are accommodated.

PART 2 - PRODUCTS

2.1 FIRE EXTINGUISHER CABINETS

- A. Cabinet Type: Suitable for fire extinguisher.
 - 1. Products: Subject to compliance with requirements, provide following:
 - a. Larsen's Manufacturing Company; Architectural Series with Larsen Loc.
 - b. JELL Industries.
 - 2. Products by other manufacturers are subject to approval by Architect prior to bidding.

- B. Cabinet Construction: Narrated.
- C. Cabinet Material: Steel sheet.
 - 1. Shelf: Same metal and finish as cabinet.
- D. Semi-Recessed Cabinet: Cabinet box partially recessed in walls of sufficient depth to suit style of trim indicated; with one-piece combination trim and perimeter door frame overlapping surrounding wall surface with exposed trim face and wall return at outer edge (backbend). Provide where indicated on Drawings.
 - 1. Rolled-Edge Trim: 2-1/2-inch (64-mm) depth.
- E. Cabinet Trim Material: Steel sheet.
- F. Door Material: Steel sheet.
- G. Door Style: Vertical duo panel with frame.
- H. Door Glazing: Acrylic sheet.
 - 1. Acrylic Sheet Color: Clear transparent acrylic sheet.
- I. Door Hardware: Manufacturer's door-operating hardware of proper type for cabinet type, trim style, and door material and style indicated.
 - 1. Provide projecting door handle.
 - 2. Provide manufacturer's standard hinge permitting door to open 180 degrees.
- J. Accessories:
 - 1. Door Lock: Cam lock that allows door to be opened during emergency by pulling sharply on door handle.
- K. Finishes:
 - 1. Manufacturer's standard baked-enamel paint.
- L. Size: (Inside Dimensions):
 - 1. Semi-Recessed: 24 inches high x 9 inches wide x 6 inches deep.
 - 2. Verify required kitchen fire extinguisher size with local authorities and provide increased cabinet size at second kitchen fire extinguisher location as required.
- M. Lettering:
 - 1. Text reading "Fire Extinguisher" shall be included on glass or metal door face.

PART 3 - EXECUTION

3.1 EXAMINATION

- A. Examine walls and partitions for suitable framing depth and blocking where semi-recessed cabinets will be installed.
- B. Proceed with installation only after unsatisfactory conditions have been corrected.

3.2 PREPARATION

- A. Prepare recesses for semi recessed fire protection cabinets as required by type and size of cabinet and trim style.

3.3 INSTALLATION

- A. General: Install fire protection cabinets in locations and at mounting heights indicated below:
 - 1. Fire Extinguisher Cabinets: 52-54 inches (1372 mm) above finished floor to top of cabinet. Verify mounting height with local fire jurisdiction.
- B. Fire Extinguisher Cabinets: Fasten cabinets to structure, square and plumb.

3.4 ADJUSTING AND CLEANING

- A. Remove temporary protective coverings and strippable films, if any, as fire protection cabinets are installed unless otherwise indicated in manufacturer's written installation instructions.
- B. Adjust fire protection cabinet doors to operate easily without binding. Verify that integral locking devices operate properly.
- C. On completion of fire protection cabinet installation, clean interior and exterior surfaces as recommended by manufacturer.
- D. Touch up marred finishes or replace fire protection cabinets that cannot be restored to factory-finished appearance. Use only materials and procedures recommended or furnished by fire protection cabinet and mounting bracket manufacturers.
- E. Replace fire protection cabinets that have been damaged or have deteriorated beyond successful repair by finish touchup or similar minor repair procedures.

END OF SECTION 104413

THIS PAGE INTENTIONALLY BLANK

SECTION 104416 - FIRE EXTINGUISHERS

PART 1 - GENERAL

1.1 RELATED DOCUMENTS

- A. Drawings and general provisions of the Contract, including General and Supplementary Conditions and Division 01 Specification Sections, apply to this Section.

1.2 SUMMARY

- A. Section includes portable, hand-carried fire extinguishers.
- B. Related Sections:
 - 1. Division 10 Section "Fire Extinguisher Cabinets."
- C. Provide one fire extinguisher for each fire extinguisher cabinet indicated.
- D. Provide fire extinguishers fully charged, inspected and tagged by agency having jurisdiction, and ready for use.

1.3 SUBMITTALS

- A. Product Data: For each type of product indicated. Include rating and classification, material descriptions, dimensions of individual components and profiles, and finishes for fire extinguisher.
- B. Product Schedule: For fire extinguishers. Coordinate final fire extinguisher schedule with fire protection cabinet schedule to ensure proper fit and function.
- C. Operation and Maintenance Data: For fire extinguishers to include in maintenance manuals.
- D. Warranty: Sample of special warranty.

1.4 QUALITY ASSURANCE

- A. NFPA Compliance: Fabricate and label fire extinguishers to comply with National Fire Protection Association (NFPA) NFPA 10, "Portable Fire Extinguishers."
- B. Fire Extinguishers: Listed and labeled for type, rating, and classification by an independent testing agency acceptable to authorities having jurisdiction.
 - 1. Provide fire extinguishers approved, listed, and labeled by FM Global (FMG).

1.5 COORDINATION

- A. Coordinate type and capacity of fire extinguishers with fire protection cabinets to ensure fit and function.

1.6 WARRANTY

- A. Special Warranty: Manufacturer's standard form in which manufacturer agrees to repair or replace fire extinguishers that fail in materials or workmanship within specified warranty period.
 - 1. Failures include, but are not limited to, the following:
 - a. Failure of hydrostatic test according to NFPA 10.
 - b. Faulty operation of valves or release levers.
 - 2. Warranty Period: Six years from date of Substantial Completion.

PART 2 - PRODUCTS

2.1 PORTABLE, HAND-CARRIED FIRE EXTINGUISHERS

- A. Fire Extinguishers: Type, size, and capacity for each fire protection cabinet indicated.
 - 1. Manufacturers: Subject to compliance with requirements, provide products by one of the following:
 - a. Kidde Residential and Commercial Division: Subsidiary of Kidde plc.
 - b. Larsen's Manufacturing Company.
 - c. Potter Roemer LLC.
 - 2. Products by other manufacturers are subject to approval by Architect prior to bidding.
 - 3. Valves: Manufacturer's standard.
 - 4. Handles and Levers: Manufacturer's standard.
 - 5. Instruction Labels: Include pictorial marking system complying with NFPA 10, Appendix B.
- B. Wet-Chemical Type (for Kitchen Area): UL-rated 2-A:1-B:C:K, 10-lb (4.5-kg) nominal capacity, with potassium acetate-based chemical in stainless-steel container; with pressure-indicating gage.
- C. Multipurpose Dry-Chemical Type in Steel Container: (One of two fire extinguishers in Kitchen and at all other locations in building) UL-rated 4-A:60-B:C, 10-lb (4.5-kg) nominal capacity, with monoammonium phosphate-based dry chemical in enameled-steel container.

2.2 EXAMINATION

- A. Examine fire extinguishers for proper charging and tagging.

1. Remove and replace damaged, defective, or undercharged fire extinguishers.
- B. Proceed with installation only after unsatisfactory conditions have been corrected.

2.3 INSTALLATION

- A. General: Install fire extinguishers in locations indicated and in compliance with requirements of authorities having jurisdiction.

END OF SECTION 104416

THIS PAGE INTENTIONALLY BLANK

SECTION 113013 - RESIDENTIAL APPLIANCES

PART 1 – GENERAL

1.1. RELATED DOCUMENTS

- A. Drawings and general provisions of the Contract, including General and Supplementary Conditions and Division 1 Specification Sections, apply to this Section.

1.2. SUMMARY

- A. This Section includes the following types of residential appliances:

- 1. Dishwasher.
- 2. Refrigerator
- 4. Washer.
- 5. Dryer.

- B. Provide residential appliances in accordance with "APPLIANCE SCHEDULE" in Part 3 of this specifications section.

1.3. SUBMITTALS

- A. General: Submit the following according to Conditions of the Contract and Division-1 Specification Sections.
- B. Product data for each appliance type required indicating compliance with requirements, including installation instructions. Provide complete operating and maintenance instructions for each appliance.

1.4. QUALITY ASSURANCE

- A. Energy Ratings: Provide residential appliances that carry labels indicating energy cost analysis (estimated annual operating costs) and efficiency information as required by Federal Trade Commission.
- B. UL and NEMA Compliance: Provide electrical components required as part of residential appliances that are listed and labeled by UL and comply with applicable NEMA standards.
- C. Single-Source Responsibility: Obtain appliances from a single supplier.
 - 1. Provide products from the same manufacturer for each type of appliance required.

1.5. DELIVERY AND STORAGE

- A. Deliver appliances to the Project site in the manufacturer's undamaged protective packaging.
- B. Delay delivery of appliances until utility rough-in is complete and construction in the spaces to receive appliances is substantially complete and ready for installation.

1.6. WARRANTY

- A. Warranty: Submit written warranties executed by the manufacturer of each appliance specified agreeing to repair or replace units or components that fail in materials or workmanship within the specified warranty period.
- B. Warranty specified above shall not deprive the Owner of other rights the Owner may have under other provisions of the Contract Documents and will be in addition to and run concurrent with Contract Documents.

PART 2 - PRODUCTS

2.1 MANUFACTURERS

- A. Manufacturers: Subject to compliance with requirements, provide appliances by the manufacturer indicated in "APPLIANCE SCHEDULE" in Part 3 of this specifications section.
- B. Equivalent products by other manufacturers are subject to approval prior to bidding.

PART 3 - EXECUTION

3.1. INSTALLATION

General: Comply with manufacturer's instructions and recommendations.

- A. Freestanding Equipment: Place units in final locations after finishes have been completed in each area. Verify that clearances are adequate to properly operate equipment.
- B. Utilities: Refer to Division 26 for electrical requirements.

3.2. ADJUST AND CLEAN

- A. Testing: Test each item of residential equipment to verify proper operation. Make necessary adjustments.

3.3. APPLIANCE SCHEDULE

- A. Dishwasher: General Electric Under-Counter Built-In.
 - 1. Model: GDT226SSLSS, stainless steel finish with SaniWash cycle feature.
- B. Refrigerator: General Electric upright.
 - 1. Model: GSS23GSKSS, 22 cu. ft. stainless steel finish side by side with water and ice dispenser.
- C. Washing Machine: General Electric with stainless steel basket.
 - 1. Model: GTW465ASNWW, 4.5 DOE cu. ft. capacity with white finish.
- D. Clothes Dryer: General Electric electric dryer.
 - 1. Model: GTD42EASJWW, 7.2 cu. ft. capacity with white finish.

END OF SECTION 113013

THIS PAGE INTENTIONALLY BLANK

SECTION 114000 - FOODSERVICE EQUIPMENT

PART 1 - GENERAL

1.1 RELATED DOCUMENTS

- A. Drawings and general provisions of the Contract, including General and Supplementary Conditions and Division 01 Specification Sections, apply to this Section.
- B. Refer to additional items specified on the Drawings that are not included in this Specification.

1.2 SUMMARY

- A. Section Includes:
 - 1. Fabricated items and equipment.
 - 2. Cooking equipment.
 - 3. Walk-in refrigeration equipment.
 - 4. Powered food-preparation equipment.
 - 5. Ware washing equipment.
 - 6. Serving equipment.
 - 7. Tables, shelving, and storage racks.
- B. Refer to Drawing Sheet A-3.7 for a complete list of all equipment.
- C. Owner-Furnished Equipment: Where indicated, Owner will furnish equipment for installation by Contractor.
- D. Related Sections:
 - 1. Division 21, 22, and 23 Sections for supply and exhaust fans; exhaust ductwork; service roughing-ins; drain traps; atmospheric vents; valves, pipes, and fittings; fire-extinguishing systems; and other materials required to complete foodservice equipment installation.
 - 2. Division 23 Section "Commercial-Kitchen Hoods" for ventilation hoods.
 - 3. Division 26 Sections for connections to fire-alarm systems, wiring, disconnect switches, and other electrical materials required to complete foodservice equipment installation.

1.3 SUBMITTALS

- A. Product Data: For each type of product indicated. Include the following:
 - 1. Manufacturer's model number.
 - 2. Accessories and components that will be included for Project.
 - 3. Clearance requirements for access and maintenance.
 - 4. Utility service connections for water, drainage, power, and fuel; include roughing-in dimensions.

- B. Shop Drawings: For fabricated equipment. Include plans, elevations, sections, roughing-in dimensions, fabrication details, utility service requirements, and attachments to other work.
- C. Samples for Initial Selection: For units with factory-applied color finishes.
- D. Samples for Verification: For each factory-applied color finish required, in manufacturer's standard sizes.
- E. Coordination Drawings: For foodservice facilities.
 - 1. Indicate locations of foodservice equipment and connections to utilities.
 - 2. Key equipment using same designations as indicated on Drawings.
 - 3. Include plans and elevations; clearance requirements for equipment access and maintenance; details of equipment support; and utility service characteristics.
 - 4. Include details of seismic bracing for equipment.
- F. Operation and Maintenance Data: For foodservice equipment to include in emergency, operation, and maintenance manuals. In addition to items specified in Division 01 Section "Operation and Maintenance Data," include the following:
 - 1. Product Schedule: For each foodservice equipment item, include the following:
 - a. Designation indicated on Drawings.
 - b. Manufacturer's name and model number.
 - c. List of factory-authorized service agencies including addresses and telephone numbers.
- G. Warranty: Samples of special warranty.

1.4 QUALITY ASSURANCE

- A. NSF Standards: Provide equipment that bears NSF Certification Mark or UL Classification Mark certifying compliance with applicable NSF standards.
- B. BISSC Standards: Where applicable, provide bakery equipment that complies with BISSC/Z50.2.
 - 1. Provide BISSC-certified equipment.
- C. UL Certification: Provide electric and fuel-burning equipment and components that are evaluated by UL for fire, electric shock, and casualty hazards according to applicable safety standards, and that are UL certified for compliance and labeled for intended use.
- D. Steam Equipment: Provide steam-generating and direct-steam heating equipment that is fabricated and labeled to comply with ASME Boiler and Pressure Vessel Code.
- E. Regulatory Requirements: Install equipment to comply with the following:
 - 1. ASHRAE 15, "Safety Code for Mechanical Refrigeration."
 - 2. NFPA 54, "National Fuel Gas Code."
 - 3. NFPA 70, "National Electrical Code."

- 4. NFPA 96, "Ventilation Control and Fire Protection of Commercial Cooking Operations."
- F. Seismic Restraints: Comply with SMACNA's "Kitchen Ventilation Systems and Food Service Equipment Fabrication and Installation Guidelines," Appendix A, "Seismic Restraint Details," unless otherwise indicated.
- G. Preinstallation Conference: Conduct conference at Project site.

1.5 PROJECT CONDITIONS

- A. Field Measurements: Verify actual dimensions of construction contiguous with foodservice equipment by field measurements before fabrication. Indicate measurements on Coordination Drawings.

1.6 COORDINATION

- A. Coordinate foodservice equipment layout and installation with other work, including layout and installation of lighting fixtures, HVAC equipment, and fire-suppression system components.
- B. Coordinate locations and requirements of utility service connections.
- C. Coordinate sizes, locations, and requirements of the following:
 - 1. Overhead equipment supports.
 - 2. Equipment bases.
 - 3. Floor depressions.
 - 4. Insulated floors.
 - 5. Floor areas with positive slopes to drains.
 - 6. Floor sinks and drains serving foodservice equipment.
 - 7. Roof curbs, equipment supports, and penetrations.

1.7 WARRANTY

- A. Refrigeration Compressor Warranty: Manufacturer's standard form in which manufacturer agrees to repair or replace compressors that fail in materials or workmanship within specified warranty period.
 - 1. Failure includes, but is not limited to, inability to maintain set temperature.
 - 2. Warranty Period: Five years from date of Substantial Completion.

PART 2 - PRODUCTS

2.1 FABRICATED ITEMS AND EQUIPMENT

- A. Stainless-Steel Dish Table. Refer to Drawings. Also refer to Drawings for pre-rinse unit.

1. Description: Dish table with trough and garbage disposal sink. Fabricate unit of welded stainless steel, sound deadened, with custom guide assembly and strainer per Drawings.
 - a. Bowl / Trough: Stainless steel, Type 304, 0.078 inch (1.98 mm) (14 gage) thick.
 - b. Integral Drainboard: Stainless steel, Type 304, 0.078 inch (1.98 mm) thick.
 - c. Body: Stainless steel, Type 304, 0.078 inch (1.98 mm) thick.
 - 1) Back Splash: 13 inches (330 mm).
 - 2) Side Splash: 13 inches (330 mm).
 - 3) Bullnose front edge.
 - d. Legs and Feet: Stainless-steel tubing legs with adjustable bullet feet.
 - e. Accessories:
 - 1) Faucets and Spouts. See Drawings.
 - 2) Prerinse Faucet.
 - 3) Vacuum breaker.
 - 4) Dam strainer.
 - 5) Continuous waste.
 - 6) Scrap trough.
 - 7) Scrap hole with collar.
 2. Stainless-Steel Sheet: ASTM A 240/A 240M, austenitic stainless steel, type as indicated.
 3. Fabrication: Prepare dish table and sink for installation of the following equipment items:
 - a. Booster water heater on dish machine.
 - b. Garbage disposal.
 4. Stainless-Steel Finish: Directional satin finish, No. 4.
- B. Stainless-Steel Prep / Clean Tables (Counters): Refer to Drawings. Also refer to Drawings for faucets and pre-rinse unit.
1. Top Construction:
 - a. Material: Stainless steel, Type 304, 0.0781-inch (14 gage) specified thickness, reinforced and sound deadened.
 - b. Back Splash: Manufacturer's standard height.
 - c. Edge: Bullnose.
 2. Undershelf:
 - a. Stainless steel, Type 304, 0.0500-inch (1.3-mm) specified thickness.
 - b. Welded.
 3. Cross bracing:
 - a. Welded to legs.
 - b. Stainless-steel tubing.

4. Sinks: Stainless steel, Type 304, 0.0781-inch (2.0-mm) specified thickness, welded into table top and including the following at the two-compartment sink and three-compartment sink:
 - a. Faucet and Spout: See Drawings.
 - b. Vacuum breaker.
 - c. Lever waste.
 - d. Basket strainer.
 5. Legs: Stainless-steel tubing.
 6. Feet: Stainless-steel adjustable bullets.
- C. Stainless-Steel Restroom Shelving: 14 gauge stainless steel per details on Drawings.

2.2 COOKING EQUIPMENT

- A. (Refer to Kitchen Equipment Schedule for additional items and accessories)
- B. Ovens:
 1. Products: Subject to compliance with requirements, provide the following:
 - a. Vulcan VC44GD – Double Stack.
 2. Description: Gas Convection
 - a. Double stack.
 - b. Accessories:
 - 1) Oven Rack(s):
 - 2) Stacking kit.
 - 3) 4" Castors, front with locks.
 - c. Electrical Service: Equip unit for connection to service indicated on Drawings.
- C. Hot Food Warmer Cabinets:
 1. Products: Subject to compliance with requirements, provide the following:
 - a. Warmer: Metro C539-CDC
 2. Description: Electric warmer cabinets.
 - a. Accessories:
 - 1) 5" Castors.
 - b. Electrical Service: Equip unit for connection to service as indicated on Drawings.

D. Combi Ovens:

1. Products: Subject to compliance with requirements, provide the following:
 - a. Rational iCombi Pro 20-Half NG
2. Description: Stainless steel, Type 304.
 - a. Type: Gas
 - b. Steam Mode Output: 36kW
 - c. Convection Mode Output: 36kw
 - d. Accessories:
 1. (4) Perforated stainless steel containers per unit.
 2. (4) Solid stainless steel containers per unit.
 3. (4) Stainless steel grids per unit.
 - e. Electrical Service: Equip unit for connection to service indicated on Drawings.
3. Stainless-Steel Sheet: ASTM A 240/A240M, austenitic stainless steel, type as indicated.
4. Stainless-Steel Finish: Directional satin finish, No. 4.

E. Food Mixers:

1. Products: Subject to compliance with requirements, provide the following:
 - a. Hobart HL300-1STD, Floor model.
 - b. Hobart HL600-1STD, Floor model
2. Description: Stainless steel, Type 304.
 - a. Capacity: 30 quart and 60 quart.
 - b. Accessories:
 1. Provide standard package of manufacturer's accessories.
 2. Slicer / grater attachment.
 3. Bowl cart.
 - c. Electrical Service: Equip unit for connection to service indicated on Drawings.

F. Steam Jacketed Kettles:

1. Products: Subject to compliance with requirements, provide the following:
 - a. "Cleveland" KGT-12-T with ST-28

2. Description: Stainless steel, Type 304.
 - a. Type: Tilting.
 - b. Steam Source: Self-contained, gas powered.
 1. Operating Steam Pressure: 50 psig (345 kPA).
 - c. Capacity: 12 gal.
 - d. Accessories:
 1. Basket insert.
 2. Spring assisted Lift-off cover.
 3. Single-pantry water filler.
 4. Tangent Draw off: 2 inches (50 mm).
 5. Disc Strainer: 1/8 inch (3 mm), perforated.
 6. Interior Finish: Manufacturer's standard.
 7. Cold-water jacket cooling.
 8. Steam trap assemblies.
 9. Kettle brush kit.
 10. Hot and cold-water faucet with swing spout.
 11. 2" tangent draw off value and spring assist stainless steel cover.
 - e. Electrical Service: Equip unit for connection to service indicated on Drawings.
3. Stainless-Steel Sheet: ASTM A 240/A240M, austenitic stainless steel, type as indicated.
4. Stainless-Steel Finish: Directional satin finish, No. 4.
5. See Drawings for Pot and Kettle Filler.

2.4 REFRIGERATION EQUIPMENT

A. Walk-in Refrigeration Units:

1. Products: Subject to compliance with requirements, provide the following:
 - a. Kolpak Custom Walk-ins – Refer to Drawings for size.
2. Description: Cooler and Freezer.
 - a. Wall and Ceiling Panels: 4" interlocking insulating panels.
 - b. Floors: 4" insulated floor panels with slip resistant finish.
 - c. Doors:
 - 1) Hinges: Two per door.
 - 2) Latch: Edge-mounted, positive-type latch with cylinder lock.
 - 3) Include safety-release handle that opens door from inside when door is locked.
 - d. Door Accessories:

- 1) Pressure relief port.
 - 2) Threshold: Stainless steel, factory installed.
- e. Vaporproof Lighting Fixtures: Incandescent fixture with 100-W lamp.
- 1) Control: Neon pilot light and toggle switch located on exterior of door panel.
 - 2) Quantity: One per compartment, located on door panel.
- f. Refrigeration System: Remote system with preassembled condensing unit and evaporator assemblies.
- 1) Exterior Condensing Units: Include winter control, crankcase heater, and enclosed weatherproof housing.
 - 2) Mechanical platform for roof mounted installation provided by Mechanical. Platform to be Miro Industries Heavy Duty mechanical galvanized roof support with adjustable support legs. Support shall extend a minimum of 6" beyond equipment in each direction. Bolt equipment to mechanical support, refer to Mechanical Sheets.
- g. Temperature Monitoring System: Electronic monitoring and remote audible alarm system that warns when temperatures register 10 deg F (6 deg C) above or below set temperature.
- h. Closure Panels and Trim: Include closure panels and trim.
- i. Electrical Service: Equip unit for connection to service indicated on Drawings.
3. Finishes:
- a. Exposed Exterior Finish: Stucco-patterned aluminum with white baked-on polyester enamel finish.
 - b. Unexposed Exterior Finish: Stucco-patterned, metallic-coated steel.
 - c. Interior Finish: Stucco-patterned aluminum with slip resistant finish at floor.
 - d. Closure Panels and Trim: Matched to exposed exterior finish of panels. Extend panels to the adjacent wall and ceiling surfaces.

B. Reach-in Refrigeration Unit:

1. Products: Subject to compliance with requirements, provide the following:
 - a. Beverage Air, Model HRS2HC-1G
 - b. Double glass doors.

2.5 WARE WASHING EQUIPMENT

A. Ware washing Machines:

1. Products: Subject to compliance with requirements, provide the following:
 - a. ADS HT – 25, with Built-On Booster Heater.

- b. Electric service.
- 2. Description: Dishwashing, single tank.
 - a. Accessories: 4-Pegged Dish Racks, 4-sheet pan racks.
 - b. Electrical Service: Equip unit for connection to service indicated on Drawings.
- B. Booster Heater:
 - 1. Products: Subject to compliance with requirements, provide the following:
 - a. ADS HT-25 Built-On.
 - b. Electric service.
 - c. Make connection to the ware washing machine. Mount undercounter.
- C. Food Waste Disposer:
 - 1. Products: Subject to compliance with requirements, provide the following:
 - a. Insinkerator SS-300.
 - b. Electric service.
 - 2. Accessories:
 - a. Short body model.
 - b. CC-101 control center.

2.6 SERVING EQUIPMENT

- A. Serving Table Drop-In-Units:
 - 1. Products: Subject to compliance with requirements, provide the following:
 - a. Advance Tabco Slimline, DISLSW-2-240
 - 2. Description: Hot food drop-in set in custom stainless steel counter.
 - a. Construction: Heavy gauge, 300 series stainless steel.
 - b. Accessories:
 - 1. Stainless steel spillage pans SP-S.
 - 2. Drain plug.
 - c. Electrical Service: Equip unit for connection to service indicated on Drawings.
- B. Food Shields:
 - 1. BSI – XGUARD Food Shields. Model No. ZG3500-3 with SSU5-H.

- a. 1/4" tempered glass.
- b. Through-counter mounted. Attach to serving counter mounting plates. Provide manufacturer mounting accessories as required.
- c. Brushed aluminum finish.
- d. Refer to Drawings for quantities and lengths.

2.7 ICE MAKERS

- A. Manitowoc RNP0620A with D-420 bin and water filter.
- B. Manitowoc CNF0201A above-counter with AR10000P water filter. (Locate at Faculty Room).

2.8 FOOD SLICER

- A. Hobart HS-7, table top model.

2.9 WIRE SHELVING

- A. Metro Super Erecta epoxy-coated units with Microban protection. See Drawings for size and tier requirements, and cooler / freezer unit requirements.
- B. Metro PR48VX3-XDR mobile drying rack.

2.10 STAINLESS STEEL TABLES, SHELVING, AND RACKS

- A. See Drawings for models, sizes, and accessories.
 - 1. Duke tables with drawers, bins, and undershelves as noted on Drawings.
 - 2. John Boos wall shelves with pot hooks as noted on Drawings.
 - 3. Lakeside #335 can rack. Size per Drawings.

2.11 FINISHES, GENERAL

- A. Stainless-Steel Finishes:
 - 1. Surface preparation: Remove tool and die marks and stretch lines or blend into finish.
 - 2. Polished Finishes: Grind and polish surfaces to produce uniform finish, free of cross scratches.
 - a. Run grain of directional finishes with long dimension of each piece.
 - b. When polishing is completed, passivate and rinse surfaces. Remove embedded foreign matter and leave surfaces chemically clean.
- B. Powder-Coat Finishes: Immediately after cleaning and pretreating, electrostatically apply manufacturer's standard, baked-polymer, thermosetting powder finish. Comply with resin manufacturer's written instructions for application, baking, and minimum dry film thickness.

2.12 MISCELLANEOUS MATERIALS

- A. Installation Accessories, General: NSF certified for end-use application indicated.

- B. Elastomeric Joint Sealant: ASTM C 920; silicone. Type S (single component), Grade NS (nonsag), Class 25, Use NT (nontraffic) related to exposure, and Use M, G, A, or O as applicable to joint substrates indicated.
 - 1. Public Health and Safety Requirements:
 - a. Sealant is certified for compliance with NSF standards for end-use application indicated.
 - b. Washed and cured sealant complies with the FDA's regulations for use in areas that come in contact with food.
 - 2. Cylindrical Sealant Backing: ASTM C 1330, Type C, closed-cell polyethylene, in diameter greater than joint width.

PART 3 - EXECUTION

3.1 INSTALLATION

- A. Install foodservice equipment level and plumb, according to manufacturer's written instructions.
 - 1. Connect equipment to utilities.
 - 2. Provide cutouts in equipment, neatly formed, where required to run service lines through equipment to make final connections.
- B. Complete equipment assembly where field assembly is required.
 - 1. Provide closed butt and contact joints that do not require a filler.
 - 2. Grind field welds on stainless-steel equipment until smooth and polish to match adjacent finish.
- C. Install equipment with access and maintenance clearances that comply with manufacturer's written installation instructions and with requirements of authorities having jurisdiction.
- D. Install cabinets and similar equipment on bases in a bed of sealant.
- E. Install closure-trim strips and similar items requiring fasteners in a bed of sealant.
- F. Install joint sealant in joints between equipment and abutting surfaces with continuous joint backing unless otherwise indicated. Produce airtight, watertight, vermin-proof, sanitary joints.

3.2 CLEANING AND PROTECTING

- A. After completing installation of equipment, repair damaged finishes.
- B. Clean and adjust equipment as required to produce ready-for-use condition.
- C. Protect equipment from damage during remainder of the construction period.

3.3 DEMONSTRATION

- A. Engage a factory-authorized service representative to train Owner's maintenance personnel to adjust, operate, and maintain foodservice equipment.

END OF SECTION 11400

SECTION 115213 - PROJECTION SCREENS

PART 1 – GENERAL

1.1. RELATED DOCUMENTS

- A. Drawings and general provisions of Contract, including General and Supplementary Conditions and Division 1 Specification Sections, apply to this Section.

1.2. SUMMARY

- A. This section includes the following:
 - 1. Electrically operated front projection screen.

1.3. SUBMITTALS

- A. General: Submit the following in accordance with Conditions of Contract and Division 1 Specification Sections.
- B. Product data for each type of screen specified. Show the following:
 - 1. Anchorage details.
 - 2. Accessories.
- C. Wiring diagram for electrically operated units.
- D. Shop drawings showing layout and types of projection screens. Show the following:
 - 1. Location of screen centerline.
 - 2. Location of wiring connections.
 - 3. Anchorage details.
 - 4. Accessories.

1.4. QUALITY ASSURANCE

- A. Coordination of Work: Coordinate layout and installation of projection screens with other construction supported by, or penetrating through, ceilings, including light fixtures, and fire-suppression system.

1.5. DELIVERY, STORAGE, AND HANDLING

- A. Do not deliver projection screens until building is enclosed, other construction within spaces where screens will be installed is substantially complete, and installation of screens is ready to take place.
- B. Protect screens from damage during delivery, handling, storage, and installation.

PART 2 - PRODUCTS

2.1. PROJECTION SCREEN SURFACES, GENERAL

- A. Material and Viewing Surface of Front Projection Screens: Obtain screens manufactured from mildew - and flame-resistant fabric of type indicated for each type of screen specified.
 - 1. Matte white viewing surface.
 - 2. Seamless Construction: Provide screens in sizes indicated without seams.
 - 3. Mildew Resistance: Provide mildew-resistant screen fabrics.
 - 4. Fire Performance Characteristics: Provide projection screen fabrics identical to those materials that have undergone testing and passed requirements for flame resistance as indicated below:
 - a. NFPA 701 per small-scale test.

2.2. ELECTRICALLY OPERATED FRONT PROJECTION SCREENS

- A. General: Provide manufacturer's standard UL-listed and UL-marked units consisting of case, screen, motor, controls, mounting accessories, and other components required for a complete installation and to comply with requirements indicated for screen surface and controls and for case, motor, and screen under description of operation and type. Remotely control operation of each screen to comply with the following:
 - 1. Single Station Control: Three-position, UL-listed control switch for each screen with metal device box and cover plate for flush wall mounting and for connection to 120 V a.c. power supply.
- B. End-Mounted-Motor-Operated Screens with Top, Front, and End Closure: Units designed and fabricated for wall surface installation with bottom of case entirely or partially open under screen compartment, to allow lowering and raising of screen but closed under motor compartment, and as follows:
 - 1. Screen Case: Metal sides and top with metal-lined motor compartment, **factory finished color as selected by Architect.**
 - 2. Motor: Instant reversing, gear drive motor of size and capacity recommended by screen manufacturer with permanently lubricated ball bearings, automatic thermal overload protection, preset limit switches to automatically stop screen in "up" and "down" positions, and positive stop action to prevent coasting. Locate motor in its own compartment as follows:

- a. On Right end of screen, unless otherwise indicated.
- 3. Screen: As indicated below, with top edge mounted on, and securely anchored to, rigid metal roller supported by self-aligning bearings in brackets.
 - a. Material: Supported Fiberglass, Matte White.
 - b. Size of Viewing Surface: 20'-0" wide x 11'-3" high.
 - c. Extra drop material (flat black). Bottom of viewing surface at 5'-0" AFF.

2.3. PRODUCTS

- A. Subject to compliance with requirements, provide the following:
 - B. Wall Mounted-Motor-Operated Screen.
 - 1. "Tensioned Professional Electrol," 20 feet 0 inches wide x 11 feet 3 inches, Da-Lite Screen Co., Inc.
 - 2. Provide all necessary mounting brackets and components for a wall mounted installation.
 - C. Other products are subject to approval prior to bidding.

PART 3 - EXECUTION

3.1. INSTALLATION

- A. General: Install projection screens at locations indicated in compliance with screen manufacturer's instructions.
 - 1. Test electrically operated units to verify that screen, controls, limit switches, closure and other operating components are in optimum functioning condition.

3.2. PROJECTION AND CLEANING

- A. Protect projection screens after installation from damage during construction. If despite such protection damage occurs, remove and replace damaged components or entire unit as required to provide units in their original, undamaged condition.

END OF SECTION 115213

THIS PAGE INTENTIONALLY BLANK

SECTION 116143 - PLATFORM CURTAINS

PART 1 GENERAL

1.1. RELATED DOCUMENTS:

- A. Drawings and general provisions of contract, including General and Supplementary Conditions.

1.2. RELATED WORK BY OTHERS:

- A. Sufficient structural support shall be provided by others. Support to be visible and easily accessible for suspension of curtain tracks.

1.3. DESCRIPTION OF WORK:

- A. Provide Class Act Performer, manually operated platform curtain system as indicated on the drawings.
 - 1. Types of platform curtains specified in this section include the following:
 - a) Front Setting: Valance and Front curtain.
 - b) Side Setting: Leg Curtains.
 - c) Rear Setting: Rear Curtain.

1.4. QUALITY ASSURANCE:

- A. Fabricator/Installer Qualifications:
 - 1. Firm with not less than ten years of successful experience in fabrication and installation of platform curtains similar to those required for this project.
 - 2. Approved theatre rigging contractors:
 - a) Stagecraft Industries, Inc. Portland, Oregon (503) 286-1600
- B. Flame Resistance Requirements:
 - 1. Provide platform curtains, which are certified to be flame resistant in accordance with requirements of NFPA 701.
 - 2. Permanently attach label to each curtain indicating curtain is permanently and inherently flame resistant.

1.5. SUBMITTALS:

- A. Product Data: Submit manufacturer's specifications, and general recommendations, including data which substantiates that materials comply with requirements.
- B. Certification: Submit manufacturer's certification that platform curtains comply with requirements for flame resistance.
- C. Shop Drawings: Submit shop drawings, including plans, elevations, and detail sections of typical rigging elements. Show anchors, hardware, operating equipment, and other components included in manufacturer's standard product.
- D. Submit fabric manufacturer's standard color card, together with 12" square physical sample (any color) for each fabric required.

PART 2 PRODUCTS

2.1 PRODUCTS:

A. Materials:

1. Front Setting and Valance Curtain Fabric:

- a) Woven synthetic Velour: Napped fabric of 100% IFR filament polyester; 54" width minimum; not less than 48 backing ends per inch, 51 pile ends per inch, and 46 picks per inch; 1173 pile tufts per square inch; other characteristics as follows:
- b) Heavy Weight: Fabric weighing not less than 23.5 ounces per linear yard, with pile height of approximately 120 mils.
- c) Products: Subject to compliance with requirements, provide one of the following heavy weight velour fabrics:

"Charisma", K&M Fabrics, Inc.

- d) Lining: Avora synthetic liner; 54" minimum width.
- e) Color: Match Architect's samples.

2. Side and Rear Setting Curtain Fabric:

- a) Encore: 100% polyester short-napped fabric on one side, woven on other side, weighing not less than 15 oz per running yard; 62-inch minimum width.
- b) Products: Subject to compliance with requirements, provide one of the following fabrics:

"Encore" – Milliken Fabrics, Inc.

- c) Color: Match Architect's sample.

3. Metal Products:

- a) Steel Tube: 16 gauge; 1 ½" unless otherwise indicated. Paint with a flat, rust-inhibitive primer and finish coat paint.
- b) Steel Pipe: Schedule 40 1 ½" unless otherwise indicated. Paint with a flat, rust-inhibitive primer and finish coat paint.
- c) Supports, Clamps, and Anchors: Steel in manufacturer's standard gages, of adequate size to support loads, painted after fabrication.
- d) Support Chain / Aircraft Cable: Chain or aircraft cable of adequate size to support loads. Provide means for adjustment on all suspension points.
- e) Inserts, Bolts and Fasteners: Manufacturer's standard units, unless otherwise indicated.

1.6. 2.2 FABRICATION:

A. Curtains:

1. General: Provide not less than 50% additional fullness for curtains, unless otherwise indicated. Horizontal seams and fabric less than half-width are not permitted.
 - a) Vertical Hems: Provide vertical hems not less than 2" wide, double-stitched and machine-sewn with no salvage material visible from front of curtain.

- b) Turnbacks: Where specified, provide turnbacks, formed by folding 12" of face fabric back at leading edge of panels and securing by sewing across top hem and grommeting through both layers of fabric.
 - c) Top hems: Reinforce top hems by double-stitching 3-1/2" wide heavy jute webbing to top edge with minimum 1" of face fabric turned under.
 - d) Pleats: Provide fullness in curtains by sewing 6" of additional material into box pleats spaced at 12" centers along top hem reinforcing. Provide not less than #2 brass grommets spaced at 12" and centered on box pleats, for tie lines or "S" hooks.
 - e) Bottom Hems: Except for curtains which hang to floor, provide bottom hems not less than 3" deep. For floor-length curtains, provide 5" hems with separate interior heavy canvas chain pockets equipped No. 8 jack chain. Stitch chain pocket so chain rides 2" above bottom edge of curtain.
 - f) Lining: Where specifically indicated, provide lining in same fullness as face fabric, and finished 2" shorter than face fabric. Unless otherwise specified, provide lining constructed of same fiber type as face fabric. Attach lining to face fabric along bottom line at seams with 4" long strips of heavy woven cotton tape.
 - g) Sewn-In Overlaps: As needed, sew in overlaps for entrance on /off platform in wrap around back curtain. Allow for approximately 6" overlaps. Provide 1" red webbing sewn on off platform side of overlap.
 - h) Draw Handles (paging handles): Provide on off platform side of Leading and Trailing Edges of Wrap-Around back setting, 6 inch cloth handles fabricated of 1" nylon webbing inside like fabric.
2. Front Setting:
- a) Valance: Fabricate valance of heavy weight velour. No lining.
 - b) Front Curtain: Fabricate front curtain of heavy weight velour, with 12" turnbacks at leading edge. No lining.
3. Side and Rear Setting:
- a) Borders: Fabricate using 15oz Encore fabric. No lining.
 - b) Wrap around Rear Curtain: Fabricate using 15oz Encore fabric. No lining.
4. Curtain Tracks:
- a) Front Setting: Track shall be 3-1/4" I-beam, with 1-5/8" top, intermediate, and bottom flanges, extruded from mill finish 6063-T5 aluminum. Track shall be un-spliced in lengths up to 24', rigged for manual cord operation.
 - b) Provide carriers with neoprene or rubber bumper, heavy-duty swivel eye and trim chain for attachment of curtain snap or "S" hook.
 - c) Products/Manufacturers: Provide one of the following:
 - Atlas Silk Model No. 516
 - Silent Steel Model No.500
 - Stagecraft Model No. 516
 - d) Rear Setting: I Beam track rigged for walk draw operation. Carriers with neoprene or rubber bumper, heavy-duty swivel eye and trim chain for attachment of curtain "S" hooks, with end stops.

- e) Strongback Battens: Fabricate battens from 1 ½" diameter 16 gauge or Sch. 40 pipe with minimum number of joints as necessary for required lengths. Connect pipe by means of steel pipe sleeve inserts not less than 18 inches long, and secure with four bolts, or other equally secure method. Shop paint completed pipe battens with good quality paint and primer in black color.
- f) Battens: Fabricate battens from 1 ½" diameter 16 gauge or Sch. 40 pipe with minimum number of joints as necessary for required lengths. Connect pipe by means of steel pipe sleeve inserts not less than 18 inches long, and secure with four bolts, or other equally secure method. Shop paint completed pipe battens with good quality paint and primer in black color.
- g) Product/Manufactures: Provide one of the following:
 - Atlas Silk Model No. 301-w
 - Stagecraft Model No. 300-w

PART 3 EXECUTION

3.1. EXAMINATION

- A. Examine areas and conditions for compliance with requirements for supporting members, blocking, clearances, and other conditions affecting performance of platform curtain work. Proceed with installation only after unsatisfactory conditions have been corrected.

3.2. PREPARATION

- A. Furnish layouts for inserts, clips and other supports required to be installed by other trades for support of tracks and battens.

3.3. INSTALLATION

A. General:

- 1. Install materials in accordance with manufacturer's printed instructions and recommendations, and to comply with governing regulations.

B. Battens:

- 1. Install battens by suspending at proper heights with steel chains or cables spaced at not more than recommended spacing.
- 2. Secure chains either directly to structures or to inserts, or other devices which are secure and appropriate to structure.

C. Tracks:

- 1. Overhead Mounted: Drill track at intervals not greater than manufacturer's recommended spacing and fasten either directly to structural members or other devices which are secure and appropriately attached to structure.
- 2. Wall-Mounted (if required): Install tracks by suspending from manufacturer's bracket clamps securely mounted to wall construction at recommended spacing.
- 3. Overlap: for center-parting curtains with not less than 2'- 0" overlap of track sections at center, supported by special lap clamps.

D. Curtains:

- 1. Track-Hung: Secure curtains to track carriers with track manufacturer's special heavy-duty "S" hooks or snap hooks.

2. Batten-Hung: Secure curtains to pipe battens with minimum 5/8" wide x 36" long braided soft cotton tie lines.

END OF SECTION 116143

THIS PAGE INTENTIONALLY BLANK

SECTION 116600 — WALL AND FLOOR PADDING

PART 1 - GENERAL

1.1 RELATED DOCUMENTS

- A. Drawings and general provisions of the Contract, including General and Supplementary Conditions and Division 01 Specification Sections, apply to this Section.

1.2 SUMMARY

A. Section Includes:

1. Safety Wall Protection Pads for Gymnasium and Sensory Room.
2. Floor Pads.

B. Related Requirements:

1. Section 061053 "Miscellaneous Rough Carpentry" for wood backing for wall pad installation.
2. Division 08 Door, Frame & Hardware Sections.
3. Section 092216 "Non-Structural Metal Framing" for mounting for wall pad installation.
4. Section 092900 "Gypsum Board" for mounting surface for wall pad installation.
5. Section 099123 "Interior Painting" for mounting surface for wall pad installation.

1.3 ACTION SUBMITTALS

A. Product Data: For each type of product.

B. Shop Drawings: Show location of each item, dimensioned plan and elevations, large scale details, fabrication details, method of attachment, and other components.

1. Show details full size.
2. Show locations and sizes of furring, blocking, and hanging strips, including concealed blocking and reinforcement specified in other sections.
3. Show locations and sizes of cutouts and holes for other items installed on walls.
4. Accessories.

C. Samples for Initial Selection:

1. Samples of protection pad cover fabrics, 6 by 6 inches, to match existing pads as selected by architect from full range of colors.

D. Manufacturer's installation and maintenance instructions.

1.4 CLOSEOUT SUBMITTALS

- A. Maintenance Data: For wall pad installation, maintenance and cleaning.

1.5 COORDINATION

- A. Coordinate layout and installation of wall pad equipment with adjacent construction, including ceiling suspension systems, light fixtures, HVAC equipment, fire-suppression system, and partitions.

PART 2 - PRODUCTS

2.1 MANUFACTURERS

- A. Manufacturers/Products: Manufacturer's standard vinyl covered urethane wall protection pads, consisting of backer board, pad, mounting accessories, and other components necessary for a complete installation.
- B. Wall Pad Mounting: Fully concealed mounting with z-clips and other manufacturer provided accessories. Wall pads to fully cover walls, frames and doors within room.
- C. Source Limitations for Wall Protection Accessories: Obtain each type of wall protection accessories from single manufacturer. Obtain accessories, including necessary mounting hardware, from same manufacturer as wall protection accessories.

2.2 SAFETY WALL PADS

- A. General: Manufacturer's standard vinyl covered urethane wall protection pads, consisting of backer board, pad, mounting accessories, and other components necessary for a complete installation.
 - 1. Wall Pad Mounting: Fully concealed mounting with z-clips and other manufacturer provided accessories. Wall pads to fully cover walls, frames and doors within room.
- A. Basis-of-Design - Wall Pads: Subject to compliance with requirements, provide Ecovision Fire-Rated Pads, as manufactured by Draper, Inc. or a comparable product by one of the following:
 - 1. Douglas Industries.
 - 2. Schelde North America.
- B. Wall Pads — General: Surface-Mounted, vinyl wrapped pads, with standard backer: Units designed and fabricated for surface mounting on walls, fabricated from rigid backer, 2" polyurethane foam filler, with no flanges. Provide units with concealed z-clip mounting.

- C. Description:
1. Thickness: 2 inches thick, urethane-foam cushion.
 2. Density: 6 lb.
 3. Pad Size and Shape: 2 feet x 6 feet. Custom widths as required at Sensory Room.
 - a. Provide L-shaped pad(s) as needed on Sensory Room door.
 4. Backer Board: 7/16 inch, urea-formaldehyde-free OSB.
 5. Backer At Door: 7/16 inch, urea-formaldehyde-free OSB.
 6. Cover: 14 oz. durable vinyl surface, with leather grain embossed pattern.
 7. Color: Match Draper color #08 "Gray."
 8. Flammability: Class A per ASTM E 84.
 9. Construction: Cushioning material adhered to backer and panel fully wrapped with fabric which is stapled to backer such that backer is not exposed on front or sides.
- D. Provide Z clips at bottom and top channel system for wall mounting panels.

2.3 FLOOR PADS

- A. General: Manufacturer's standard urethane foam protection mats with durable vinyl surface, consisting of pad and other components necessary for a complete installation.
- B. Basis-of-Design Floor Pads: Subject to compliance with requirements, provide Ecovision Fire-Rated Pads, as manufactured by Draper, Inc. or a comparable product by the same manufacturer as the Floor Pads.
- C. Description:
1. Thickness: 2 inches thick, open-cell neoprene foam.
 2. Density: 6 lb.
 3. Pad Size: Custom sizes as required for wall to wall installation in Sensory Room.
 4. Backer Board: 7/16 inch, urea-formaldehyde-free OSB.
 5. Cover: 14 oz. durable vinyl surface, with leather grain embossed pattern.
 6. Color: Match Draper color #08 "Gray."
 7. Flammability: Class A per ASTM E 84.
 8. Construction: Cushioning material adhered to backer and panel fully wrapped with fabric which is stapled to backer such that backer is not exposed on front or sides.

PART 3 - EXECUTION

3.1 PREPARATION

- A. Field verify dimensions prior to fabrication.
- B. Coordinate fabrication of protection pads with size and location of switches, electrical outlets, and other wall mounted items; structural framing and bracing projecting from wall surface; and door and other wall openings.

3.2 INSTALLATION

- A. Install in accordance with manufacturer's written instructions and shop drawings.
- B. Safety Wall Protection Pads:
 - 1. Secure to wall with fasteners and Z clips along top and bottom. Type, size and spacing of fasteners as recommended by manufacturer.
 - 2. Neatly make cutouts for switches, electrical outlets, and other items on wall and seal with matching vinyl fabric.
- C. Floor Pads:
 - 1. Extend floor protection pad to room-side face of door/door protection pad.

3.3 PROTECTING AND CLEANING

- A. After installation, protect wall and floor protection from damage during construction. If damage occurs despite such protection, remove and replace damaged components or entire unit as required to provide units in their original, undamaged condition.

END OF SECTION 116600

SECTION 116623 – GYMNASIUM EQUIPMENT

PART 1 – GENERAL

1.1. RELATED DOCUMENTS

- A. Drawings and general provisions of Contract, including General and Supplementary Conditions and Division 1 Specifications Sections, apply to this Section.

1.2. SUMMARY

- A. This section includes the following:
 - 1. Folding backstops (Forward Fold).
 - 2. Backboards (Glass and Fiberglass).
 - 3. Goals.
 - 4. Winches (Electric).
 - 5. Volleyball posts, net, floor sleeves and cover plates.
 - 6. Safety wall pads.

1.3. SUBMITTALS

- A. Product data for each type of equipment required, with installation instructions for each unit built-in or connected to other construction. Include methods of installation for each type of substrate.
- B. Shop drawings for each type of equipment required. Folding backstop drawings shall show entire backstop and carriage assembly; installation and attachment of all components and accessories; and complete large scale installation details for special conditions.
 - 1. Shop drawings shall carry the seal of a professional engineer licensed to practice in the State of Idaho
- C. Samples for initial selection purposes consisting of manufacturer's standard size samples showing full range of standard colors and patterns available for each type of equipment required.

1.4. SYSTEM PERFORMANCE REQUIREMENTS

- A. Structural performance: Design, engineer, fabricate, and install folding backstops to withstand all structural loads without exceeding the allowable design working stresses of the materials involved, including anchors and connections. Apply each load to produce the maximum stress in each respective component of each backstop assembly.
- B. Installation requirements: Design, engineer fabricate, and install folding backstops to conform to the conditions of the building design as shown on the Drawings.

- C. Contractor shall provide purlins, beams, or other structural roof members of sufficient strength to accommodate attachment of folding backstops and related components as indicated.

1.5. QUALITY ASSURANCE

- A. Manufacturer Qualifications: Firm (material producer) for each type of equipment with not less than 3 years of production experience, whose published literature and completed installations clearly indicates general compliance of products with requirements of this section.
- B. Single Source Responsibility: Provide materials, components, and accessories produced by a single manufacturer for each type of equipment.
- C. Engineer Qualifications: Professional engineer licensed to practice in jurisdiction where project is located and experienced in providing engineering services of the kind indicated that have resulted in the successful installation of folding backstops similar in material, design, and extent to those indicated for this project.
- D. Installer Qualifications: Engage an experienced installer to perform unit of work of this section who has specialized in the installation of types of folding backstops similar to that required for this project and who is acceptable to, or certified by, manufacturer of the backstop assembly.

1.6. DELIVERY, STORAGE AND HANDLING

- A. Deliver materials to project site in original factory wrappings and containers, clearly labeled with identification of manufacturer, brand name, and lot number. Store materials in original undamaged packages and containers, inside well-ventilated area protected from weather, moisture, soiling, extreme temperatures, humidity; laid flat, blocked off ground to prevent sagging and warping.
- B. Comply with instructions and recommendations of manufacturer for special delivery, storage and handling requirements.

1.7. SEQUENCE AND SCHEDULING

- A. Sequence accessory installation with other work to minimize possibility of damage and soiling during remainder of construction period.

1.8. PROJECT CONDITIONS

- A. Field Measurements: Check actual dimensions of construction affecting folding backstops by accurate field measurements before fabrication; show recorded measurements on final shop drawings. Coordinate fabrication schedule with construction progress to avoid delay of work.

- B. Where field measurements cannot be made without delaying the work, guarantee dimensions and proceed with fabrication of folding backstops without field measurements. Coordinate wall and floor construction to ensure that actual dimensions correspond to guaranteed dimensions.

1.9. MAINTENANCE

- A. Maintenance Instructions: Submit manufacturer's printed instructions for maintenance of installed work, including methods and frequency recommended for maintaining optimum condition under anticipated use conditions. Include precautions against materials and methods which may be detrimental to finishes and performance.

PART 2 - PRODUCTS

2.1. MANUFACTURERS

- A. Manufacturers: Subject to compliance with requirements, provide products by one of the following:

- 1. Backstops, Backboards, and Goals.

- a. ADP Lemco.
- b. Spalding
- c. Draper
- d. PSS Performance Sports Systems
- e. Arizona Courtlines, Inc.
- f. Porter Athletic

- 2. Volleyball Floor Sleeves, Covers, Posts, and Net.

- a. ADP Lemco.
- b. Spalding.
- c. Draper.
- d. PSS Performance Sports Systems / Gared Holdings LLC.
- e. Arizona Courtlines, Inc.
- f. Porter Athletic

- B. Athletic equipment by other manufacturers is subject to approval prior to bidding. Refer to Instructions to Bidders.

2.2. BACKSTOPS AND BACKBOARDS

- A. Suspended Swing-up Backstop, equal to ADP Lemco Model 1325.

- 1. Backstop shall be single mast, welded frame, front braced, forward folding design, equal to Model 1325 with 6 5/8" O.D. steel tube main mast and 2 3/8" and 1 7/8" O.D. braces.

2. Backstop shall be provided with manufacturer's standard cable and pulley folding mechanism allowing the backstop assembly to be raised to near horizontal.
 - a. Cables shall be 1/4" minimum diameter galvanized aircraft cable with minimum 7,000 lb. breaking strength.
 - b. Main court backstops to be provided with motorized winch specified in Section 2.4.A.
3. Backstop shall be provided with all fittings and accessories required for a complete and fully functional installation.

C. Glass and Fiberglass Backboards

1. Provide 42" high x 72" wide rectangular shaped backboards.
 - a. Glass backboards shall be equal to ADP Lemco Model 65. Boards shall be 1/2 inch tempered glass with white border and target mounted on aluminum frame.
 - b. Fiberglass backboards shall be equal to ADP Lemco Model 75. Boards shall be furnished with non-glare white finish with orange border and target.
 - c. Each board shall be furnished with mechanically fastened (not glue-on) edge pads.

2.3. GOALS

- A. Provide one goal and one net for each backboard specified.
 1. Goals shall be equal to ADP Lemco Model 25 breakaway goal. Provide goals with height adjuster allowing adjustment between 8 and 10 feet.

2.4. MOTORIZED WINCHES

- A. Swing-up backstop shall be provided with a separate motorized winch assembly, ADP Lemco Model 150, consisting of a fully enclosed, factory lubricated and sealed electrically operated worm gear winch with a 3/4 horsepower motor designed to lift specified backstop assembly.
 1. Load Type Vertical lifting, pulling on a slope or pulling horizontally. 1200 lb. backstop assembly with a safety line stall pull of 1500 lbs.
 2. Rope Type 1/4" diameter 7 x 19 galvanized aircraft cable (7000 lb. breaking strength).
 3. Rope Travel 25' on one layer and additional 20' on second layer as required.
 4. Electrical 110 V, 60 Cycle.
 5. Motor 3/4" HP 9 AMP instant reversing, low maximum current draw design.
 6. Duty Cycle Stand: 10 minutes ON, 20 minutes OFF.

- 7. Rope Drum Grooved with through the drum anchoring.
- 8. Braking Self-locking worm gearing plus passive uni-directional brake.
- 9. Limit Switches Heavy duty upper and lower limit switches, gear driven.

2.5. SAFETY LOCKS

A. Winch shall be provided with a strap type safety lock device.

- 1. Safety locks shall be equal to ADP Lemco Model 110.

2.6. VOLLEYBALL POSTS, NETS, FLOOR SLEEVES, AND COVER PLATES

A. Floor sleeves shall be steel pipe sleeves for cast in place concrete installation.

- 1. Provide (6) sleeves, each 3 1/2" in diameter and minimum 8 3/4" long.
- 2. Sleeves shall be equal to Draper 501006.

B. Cover plates shall be brass alloy cover plates designed for flush installation on finish floor.

- 1. Provide one cover plate for each sleeve.
- 2. Cover plates shall be fully concealed, hinged type equal to Draper 501033.

C. Volleyball posts shall be adjustable type allowing for any height between 3'-6" and 8'-0".

- 1. Provide (4) side posts equal to Draper 500010.

D. Volleyball nets shall be 32 feet long by 39 3/8 inches high with rope tensioner and combination antenna and boundary marker.

- 1. Provide (3) nets equal to Draper 500014.

PART 3 - EXECUTION

3.1. INSTALLATION

A. Install basketball backstop units to comply with manufacturer's instructions and final shop drawings. Provide accessories indicated and anchors, fasteners, bracing and other items required for installation of units and permanent attachment of units to adjoining construction. Install side-fold units with 4 x 8 stand-off members supplied by others. Anchor side-fold units through stand-offs into solid grouted CMU.

- B. Install volleyball standard floor sleeves in accordance with manufacturer's standard installation details and in positions shown on the Drawings. Install one set of posts and net for inspection purposes.
- C. Install safety wall pads using manufacturer's standard mounting system.
 - 1. Secure to wall with fasteners and Z-clips along top and bottom. Type, size, and spacing of fasteners as recommended by manufacturer.
 - 2. Neatly make cutouts for switches, electrical outlets, and other items on wall and seal with matching vinyl fabric.

3.2. ADJUSTMENT AND CLEANING:

- A. Upon completion of installation, including work of other trades, lubricate, test, and adjust each backstop unit and related component to operate easily and in compliance with manufacturer's specifications.
- B. Clean installed assemblies. Touch up shop-applied finishes to restore damaged or soiled areas.

3.3. PROTECTION

- A. Provide final protection and maintain conditions, in a manner acceptable to manufacturer and Installer, that ensures that folding backstops and related components are without damage or deterioration at time of Substantial Completion.

END OF SECTION 116623

SECTION 122113 - HORIZONTAL LOUVER BLINDS

PART 1 - GENERAL

1.1 RELATED DOCUMENTS

- A. Drawings and general provisions of the Contract, including General and Supplementary Conditions and Division 01 Specification Sections, apply to this Section.

1.2 SUMMARY

- A. This Section includes the following:
 - 1. Horizontal louver blinds with aluminum slats.
 - a. Provide at exterior view windows as indicated on Drawings.

1.3 SUBMITTALS

- A. Product Data: For each type of product indicated.
- B. Samples for Color Selection: For each type and color of horizontal louver blind indicated.
 - 1. Include similar Samples of accessories involving color selection.

1.4 QUALITY ASSURANCE

- A. Source Limitations: Obtain horizontal louver blinds through one source from a single manufacturer.
- B. Fire-Test-Response Characteristics: Provide horizontal louver blinds with the fire-test-response characteristics indicated, as determined by testing identical products per test method indicated below by UL or another testing and inspecting agency acceptable to authorities having jurisdiction. Identify materials with appropriate markings of applicable testing and inspecting agency.
 - 1. Flame-Resistance Ratings: Passes NFPA 701.
- C. Product Standard: Provide horizontal louver blinds complying with WCSC A 100.1.

1.5 DELIVERY, STORAGE, AND HANDLING

- A. Deliver horizontal louver blinds in factory packages, marked with manufacturer and product name, and location of installation using same designations indicated on Drawings and in a window treatment schedule.

1.6 PROJECT CONDITIONS

- A. Environmental Limitations: Do not install horizontal louver blinds until construction and wet and dirty finish work in spaces, including painting, is complete and dry and ambient temperature and humidity conditions are maintained at the levels indicated for Project when occupied for its intended use.
- B. Field Measurements: Where horizontal louver blinds are indicated to fit to other construction, verify dimensions of other construction by field measurements before fabrication and indicate measurements on Shop Drawings. Allow clearances for operable glazed units' operation hardware throughout the entire operating range. Notify Architect of discrepancies. Coordinate fabrication schedule with construction progress to avoid delaying the Work.

PART 2 - PRODUCTS

2.1 HORIZONTAL LOUVER BLINDS, ALUMINUM SLATS

- A. Products: Subject to compliance with requirements, provide one of the following:
 - 1. Hunter Douglas;
 - 2. Levolor, a Newell Rubbermaid Company;
 - 3. Springs Window Fashions Division, Inc.;
- B. Products by other manufacturers are subject to approval by Architect prior to bidding.
- C. Slats: Aluminum; alloy and temper recommended by producer for type of use and finish indicated; with crowned profile and radiused corners.
 - 1. Width: 1 inch (25 mm).
 - a. Spacing: Not less than every 0.77 inch (19.5 mm).
 - 2. Thickness: Manufacturer's standard.
 - 3. Finish: One color.
 - a. Ionized Coating: Antistatic, dust-repellent, baked polyester finish.
- D. Headrail: Formed steel or extruded aluminum; long edges returned or rolled; fully enclosing operating mechanisms on three sides and end plugs and the following:
 - 1. Capacity: One blind per headrail.
 - 2. Integrated Headrail/Valance: Curved face.
 - 3. Light-blocking lower back lip.
 - 4. Tilt limiter with preselected degree settings.
- E. Bottom Rail: Formed-steel or extruded-aluminum tube, with plastic or metal capped ends top contoured to match crowned shape of slat; with enclosed ladders and tapes to prevent contact with sill.
- F. Ladders: Evenly spaced to prevent long-term slat sag.

1. For Blinds with Nominal Slat Width 1 Inch (25 mm) or Less: Braided string.
- G. Lift Cords: Manufacturer's standard. Provide extra length cords at clerestory windows.
- H. Tilt Control: Enclosed worm-gear mechanism, slip clutch or detachable wand preventing overrotation, and linkage rod, and the following:
1. Tilt Operation: Manual with clear plastic wand
 2. Length of Tilt Control: Full length of blind.
 3. Tilt: Full.
 4. Reach: Provide extension crank for clerestory windows.
- I. Lift Operation: Manual, cord lock; locks pull cord to stop blind at any position in ascending or descending travel.
- J. Lift Operation: Manual, top-locking cord lock; locks pull cord to stop blind in either fully opened or fully closed position only and is equipped with a ring pull not more than 4 inches (100 mm) long.
- K. Tilt-Control and Cord-Lock Position: Right and left side of headrail, respectively.
- L. Mounting: Window header mounting, permitting easy removal and replacement without damaging blind or adjacent surfaces and finishes; with spacers and shims required for blind placement and alignment indicated. Do not mount on aluminum window framing.
- M. Colors, Textures, Patterns, and Gloss: As selected by Architect from manufacturer's full range.

2.2 HORIZONTAL LOUVER BLIND FABRICATION

- A. Concealed Components: Noncorrodible or corrosion-resistant-coated materials.
1. Lift-and-Tilt Mechanisms: With permanently lubricated moving parts.
- B. Unit Sizes: Obtain units fabricated in sizes to fill window and other openings as follows, measured at 74 deg F (23 deg C):
1. Blind Units Installed between (inside) Jambs: Width equal to 1/4 inch (6 mm) per side or 1/2 inch (13 mm) total, plus or minus 1/8 inch (3.1 mm), less than jamb-to-jamb dimension of opening in which each blind is installed. Length equal to 1/4 inch (6 mm), plus or minus 1/8 inch (3.1 mm), less than head-to-sill dimension of opening in which each blind is installed.
 2. Blind Units Installed outside Jambs: Width and length as indicated, with terminations between blinds of end-to-end installations at centerlines of mullion or other defined vertical separations between openings.
- C. Installation Fasteners: No fewer than two fasteners per bracket, fabricated from metal noncorrosive to blind hardware and adjoining construction; type designed for securing to supporting substrate; and supporting blinds and accessories under conditions of normal use.
- D. Color-Coated Finish:

1. Metal: For components exposed to view, apply manufacturer's standard baked finish complying with manufacturer's written instructions for surface preparation including pretreatment, application, baking, and minimum dry film thickness.
- E. Component Color: Provide rails, cords, ladders, and exposed-to-view metal, wood, and plastic matching or coordinating with slat color, unless otherwise indicated.

PART 3 - EXECUTION

3.1 EXAMINATION

- A. Examine substrates, areas, and conditions, with Installer present, for compliance with requirements for installation tolerances, operational clearances, and other conditions affecting performance.
1. Proceed with installation only after unsatisfactory conditions have been corrected.

3.2 INSTALLATION

- A. Install horizontal louver blinds level and plumb and aligned with adjacent units according to manufacturer's written instructions, and located so exterior slat edges in any position are not closer than 2 inches (51 mm) to interior face of glass. Install intermediate support as required to prevent deflection in headrail. Allow clearances between adjacent blinds and for operating glazed opening's operation hardware if any.

3.3 ADJUSTING

- A. Adjust horizontal louver blinds to operate smoothly, easily, safely, and free of binding or malfunction throughout entire operational range.

3.4 CLEANING AND PROTECTION

- A. Clean horizontal louver blind surfaces after installation, according to manufacturer's written instructions.
- B. Provide final protection and maintain conditions, in a manner acceptable to manufacturer and installer, that ensure that horizontal louver blinds are without damage or deterioration at time of Substantial Completion.
- C. Replace damaged horizontal louver blinds that cannot be repaired, in a manner approved by Architect, before time of Substantial Completion.

END OF SECTION 122113

SECTION 126600 – TELESCOPING STANDS

PART 1 – GENERAL

1.1. RELATED DOCUMENTS

- A. Drawings and general provisions of Contract, including General and Supplementary Conditions and Division 1 Specification sections, apply to this section.

1.2. SUMMARY

- A. This Section includes the following:
 - 1. Wall-attached telescoping bleacher units, forward fold

1.3. DEFINITIONS

- A. Telescoping bleachers are operable systems of multiple-tiered benches on interconnected, folding supports that permit closing, without requiring dismantlement, into a nested relationship for purposes of storing or moving.

1.4. SYSTEM PERFORMANCE REQUIREMENTS

- A. Structural and Regulatory Performance: Design, engineer, fabricate, and install telescoping bleachers to withstand the following structural loads without exceeding the allowable design working stresses of the materials involved, including anchors and connections. Apply each load to produce the maximum stress in each respective component of each bleacher unit. Design engineer, fabricate and install telescoping bleachers to meet the following regulatory requirements:
 - 1. Design loads and Safety Standard, ICC 300, 2012 edition.
 - 2. Accessibility, Americans with Disabilities Act and ANSI A 117.1
- B. Operation: Provide telescoping bleacher units incorporating manufacturer's standard telescoping system of seating and understructure members that permit opening and closing with respect to adjacent rows, that allow any or all rows to be locked open for use, and that close with vertical faces of upper skirts in same vertical plane.
 - 1. Manual Operation: Provide manual operation of bleacher units by means of portable operator handles that attach to center of bleacher section and allow one or two operators to work from upright position.

1.5. SUBMITTALS

- A. General: Submit the following in accordance with Conditions of Contract and Division 1 Specification Sections.

- B. Product data for each type of telescoping bleacher and accessory indicated.
- C. Shop drawings indicating layout of telescoping bleacher units coordinated with field measurements and including seat heights, row spacing and rise, aisle widths and locations, accessible seating areas, overall dimensions in closed and open position, connections, and relationship to adjoining work, accessories, types of materials, and finishes.
 - 1. Where installed products are indicated to comply with certain design loadings, include structural computations, material properties, and other information needed for structural analysis that has been signed and sealed by a qualified **Idaho licensed** professional engineer responsible for their preparation. Engineering analysis shall relate to the structural integrity and code compliance of the overall bleacher assembly. Component analysis and calculations are not required.
 - 2. Shop drawings shall be reviewed and approved by Architect prior to bleacher fabrication and installation.
- D. Samples for selection purposes in form of manufacturer's color charts consisting of actual units or sections of units showing full range of colors and textures available for each exposed material involving such selections.
- E. Maintenance data for inclusion in Operating and Maintenance Manual specified in Division 1 including detailed instructions indicating proper means for operating and maintaining each type of bleacher unit and accessory required.
- F. Qualification data for firms and persons specified in "Quality Assurance" Article to demonstrate their capabilities and experience. Include list of completed projects with project names, addresses, names of Architects and Owners, and other information specified.

1.6. QUALITY ASSURANCE

- A. NFPA Standard: Comply with requirements of NFPA 102, "Standard for Assembly Seating, Tents, and Membrane Structures," and specifically with Chapter 5, "Folding and Telescopic Seating," except where more stringent requirements are indicated or imposed by authorities having jurisdiction.
- B. Installer Qualifications: Engage an experienced Installer to perform unit of work of this section who has specialized in the installation of types of telescoping bleachers similar to that required for this project and who is acceptable to, or certified by, manufacturer of telescoping bleachers.
- C. Engineer Qualifications: Professional engineer licensed to practice in jurisdiction where project is located and experienced in providing engineering services of the kind indicated that have resulted in the successful installation of telescoping bleachers similar in material, design, and extent to those indicated for this Project.
- D. Qualify welding processes and welding operators in accordance with AWS D1.1 "Structural Welding Code - Steel" and D1.3 "Structural Welding Code - Sheet Steel."

1.7. PROJECT CONDITIONS

- A. Field Measurements: Check actual dimensions of construction affecting telescoping bleachers by accurate field measurements before fabrication; show recorded measurements on final shop drawings. Coordinate fabrication schedule with construction progress to avoid delay of Work.
 - 1. Where field measurements cannot be made without delaying the Work, guarantee dimensions and proceed with fabrication of telescoping bleachers without field measurements. Coordinate wall and floor construction to ensure that actual dimensions correspond to guaranteed dimensions.

PART 2 - PRODUCTS

2.1. MANUFACTURERS

- A. Manufacturers: Subject to compliance with requirements, provide products by one of the following:
 - 1. Hussey Seating Co.
 - 2. Interkal, Inc.
 - 3. Kodiak Industries
 - 4. Sheridian
 - 5. Irwin Seating Company
- B. Products by other manufacturers are subject to approval prior to bidding.

2.2. MATERIALS

- A. Lumber: Softwood, kiln dried, surfaced 4 sides, 1-inch nominal thickness, complying with the following requirements.
 - 1. Lumber Species and Grade: Southern Pine complying with SPIB "Grading Rules" for C and Better finish grade.
 - 2. Lumber Form: Solid lumber complying with PS 20.
- B. Plywood: Softwood plywood panels, 5/8-inch nominal thickness, 5-ply construction with grade designation APA A-C Exterior, with solid crossbands, Group 1 veneer species for all plies, and exterior glue, APA grade trademarked, complying with ANSI/VOL. PROD. STD. PS-1.
- C. Structural Steel Shapes, Plates and Bars: ASTM A 36, except where higher strength steel is indicated or standard with manufacturer.
- D. Uncoated Steel Sheet: ASTM A 366, commercial quality, cold-rolled sheet, stretcher leveled.
- E. Galvanized Steel Sheet: ASTM A 526, G60 coating designation, phosphatized, stretcher leveled.
- F. Steel Tubing: ASTM A 501, hot-formed.

- G. Aluminum Tubing: ASTM B 429, 6063-T6, Schedule 40.
- H. Fasteners: Vibration-proof, of size and material standard with manufacturer.

2.3. CONSTRUCTION

- A. General: Provide manufacturer's standard telescopic bleacher system fabricated to comply with requirements indicated. Smoothly round corners, edges, and exposed fasteners, if any, to eliminate snagging and pinching hazards. Form exposed sheet metal with flat, flush surfaces, true to line and level, and without cracking and grain separation. Perform welding by operators and processes complying with AWS requirements.
- B. Seats: Provide flat top plastic continuous seating benches equal to "Hussey 10" Comfort Curve".
 - 1. Material: Contoured plastic equal to Hussey 10" Comfort Curve.
- C. Lower Risers and Foot Rests: Provide recessed lower riser and fully closed footrest construction. Fabricate riser from steel sheet with baked enamel, vinyl cladding, or galvanized finish as standard with manufacturer. Fabricate footrest from plywood as standard with manufacturer.
- D. Understructure: Fabricate understructure from structural steel members of size, spacing, and form required to support design loads with cantilevered bench seat supports to product toe space uninterrupted by vertical bracing.
- E. Support Column Wheels: Provide manufacturer's standard wheel assembly under each support column. Include wheels of size, number, and design required to support bleacher units and to achieve smooth operation without damage to flooring surface, but not less than 4 per column nor less than 3-1/2 inches in diameter and 1 inch wide.
- F. Row Spacing: Fabricate units with (3) seating rows with a row spacing of 24 inches unless otherwise indicated.
- G. Row Rise: Fabricate units with row rise of 11-5/8 inches.
- H. Type of Bleacher Units: Provide assemblies of the following type fabricated in lengths and number of rows indicated.
 - 1. Wall-Attached Type: Construct units to provide for permanent attachment of rear of understructure to wall/floor construction.
- I. Accessories: Provide the following accessories of manufacturer's standard design and construction at locations indicated or required.
 - 1. Rear fillers including supports for closing openings between top row and rear wall of adjoining construction.
 - 2. End railings of telescoping, self-storing type.
 - 3. Scorer's table of removable type for attachment to mounting sockets provided as part of bleacher unit (1 required).
 - 4. End railings of telescoping, self-storing type.

- J. Construct bleacher units with aisles and to allow for accessible seating areas as required by ICC 300 and ANSI A 117.1.

2.4. METAL FINISHES, GENERAL

- A. Comply with NAAMM "Metal Finishes Manual" for recommendations relative to application and designations of finishes.

2.5. ALUMINUM FINISHES

- A. Finish designations prefixed by "AA" conform to the system established by the Aluminum Association for designating aluminum finishes.
- B. Class I Clear-Anodized Finish: AA-M12C22A41 (Mechanical Finish: as fabricated, nonspecular; Chemical Finish: etched, medium matte; Anodic Coating: Class I Architectural, clear film thicker than 0.7 mil) complying with AAMA 607.1.

2.6. GALVANIZED STEEL SHEET FINISHES

- A. Surface Preparation: Clean surfaces of dirt, grease, and other contaminants followed by a conversion coating of type suited to organic coating applied over it. Clean welds, mechanical connections, and abraded areas; then apply galvanizing repair paint specified below to comply with ASTM A 780.
 - 1. Galvanizing Repair Paint: High zinc-dust-content paint for re-galvanizing welds in steel, complying with SSPC-Paint-20.
- B. Baked Enamel Finish: Immediately after cleaning and pretreatment, apply manufacturer's standard 2-coat baked enamel finish consisting of prime coat and thermosetting topcoat.

2.7. STEEL FINISHES

- A. Surface Preparation: Solvent-clean surfaces in compliance with SSPC-SP 1 to remove dirt, oil, grease, and other contaminants that could impair paint bond. Remove mill scale and rust, if present, from uncoated steel in compliance with SSPC-SP 5 (White Metal Blast Cleaning) or SSPC-SP 8 (Pickling).
- B. Baked Enamel Finish: Immediately after cleaning and pretreatment, apply manufacturer's standard 2-coat baked enamel finish consisting of prime coat and thermosetting topcoat to exposed and concealed metal surfaces including understructure, except where other types of finishes are indicated.

2.8. WOOD FINISHES

- A. Wood and Transparent Finish: Prepare surfaces by machine sanding, supplemented by hand sanding where required, followed by application of sealer coats and transparent top coats of type,

in number, and by process standard with manufacturer. Apply to wood surfaces except where otherwise indicated.

PART 3 - EXECUTION

3.1. INSTALLATION

- A. Install telescoping bleacher units to comply with manufacturer's instructions and final shop drawings. Provide accessories indicated and anchors, fasteners, inserts, and other items required for installation of units and permanent attachment of units to adjoining construction.

3.2. ADJUSTMENT AND CLEANING

- A. Upon completion of installation, including work of other trades, lubricate, test, and adjust telescoping bleacher unit to operate easily and in compliance with manufacturer's specifications.
- B. Clean installed bleacher units on exposed and semiexposed surfaces. Touch up shop-applied finishes to restore damaged or soiled areas.

3.3. PROTECTION

- A. Provide final protection and maintain conditions, in a manner acceptable to manufacturer and Installer that ensures that telescoping bleachers are without damage or deterioration at time of Substantial Completion.

END OF SECTION 126600